

Joie™

**USE WITH A
CHILD**

Armour™ fx

MODEL C2005A

instruction manual



**IMPORTANT: KEEP THIS INSTRUCTION BOOKLET IN THE PLACE
PROVIDED AT THE BACK OF THE CHILD RESTRAINT**

IMPORTANT:

Before installation and use of this child restraint check that it is suitable for the size of your child.

Refer to the shoulder height label information on pages 10 and 20.

REAR FACING UP TO APPROX 30 MONTHS



SUITABLE FOR:
BABIES - BIGGER TODDLERS



FORWARD FACING APPROX 12 MONTHS TO 4 YEARS

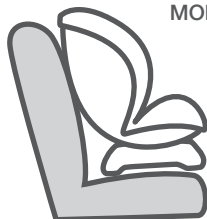

SUITABLE FOR:
BIGGER BABIES -
SMALL CHILDREN



DO NOT USE THIS CHILD RESTRAINT UNTIL YOU HAVE READ AND UNDERSTOOD THE INSTRUCTIONS IN THIS USER GUIDE AND IN YOUR VEHICLE OWNERS MANUAL

Nuna Baby Australia Pty Ltd, ACN 642 240 140, 82 Bellingara Road, Miranda, NSW 2228,
P.O. Box 2145, Taren Point, NSW 2229, Australia Phone: (02) 8543 5570 Fax: (02) 8543 5571

CONTENTS

Overview - Rear facing	2
Overview - Forward facing	3
WARNINGS	4
ADDITIONAL WARNINGS	5 & 6
Features.....	7 & 8

REAR FACING

Recline Angle	9
Shoulder Strap Height Labels	10
Shoulder Strap Height	11
Securing the Harness	12 - 14
Adjusting the Harness	15
CHECKLIST	16
Liner	17 & 18

FORWARD FACING

Recline Angle	19
Shoulder Strap Height Labels	20
Shoulder Strap Height	21
Securing the Harness	22 & 23
Adjusting the Harness	24 & 25
CHECKLIST	26
Cover Removal & Refit	27 & 28
The Next Restraint	29
Cleaning and Maintenance	30

Overview

IMPORTANT: first read the separate Quick Reference sheet, then read the following instructions carefully

Shoulder Straps - must always be at correct height and pulled tight.
See page 11 & 15

Harness Straps - must not be twisted.
See page 14

Quick Release Buckle - must always be securely fastened.
See page 14

Recline angle - use full recline for rear facing.
See page 9

Suitable clothing - child's clothing must allow the harness to securely grip the child.
See pages 13 & 16

This Child Restraint is suitable for rear facing use up to approximately 2 - 3 years of age. See page 5 for more detailed information.



Head and Infant Liners - only use for smaller children who require more support.
See page 17 & 18

Shoulder Height - shoulders must not be above the middle marker line
See page 10

Child position - child must be in full contact with back of restraint.
See page 13

Harness Tension - pull harness tight.
See page 15

Overview

IMPORTANT: first read the separate Quick Reference sheet, then read the following instructions carefully

Shoulder Straps - must always be at correct height and pulled tight.
See page 21 & 24

Harness Straps - must not be twisted.
See page 24

Quick Release Buckle - must always be securely fastened.
See page 23

Recline angle - use full recline for rear facing.
See page 19

Suitable clothing - child's clothing must allow the harness to securely grip the child. See page 23

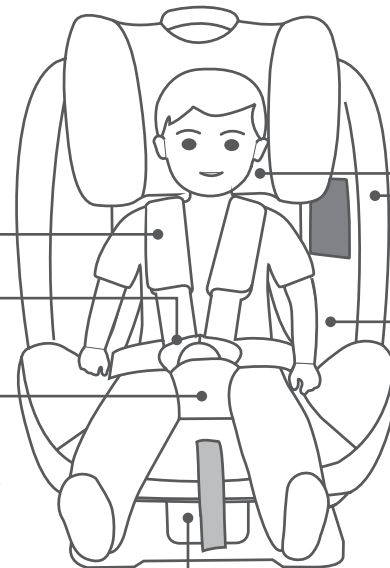

Head Liners and Infant Insert - only use for smaller children who require more support.
See page 17 & 18

Shoulder Height - shoulders must not be above the upper marker line
See page 20

Child position - child must be in full contact with back of restraint.
See page 23

Harness Tension - pull harness tight.
See page 24 & 25

WARNINGS

GENERAL WARNINGS

- Use the restraint exactly as shown in the instructions.
- Supervision of children is needed because they may be able to undo buckles.
- A loose harness or restraint is dangerous.
- Fit the harness firmly to the child.
- DO NOT USE THIS RESTRAINT WITHOUT THE COVER
- **DO NOT LEAVE CHILDREN UNATTENDED IN THE CAR**

REAR FACING WARNINGS

- To ensure that infant's back is evenly supported, do not put more than one nappy on the baby and make sure the nappy is not folded thickly at the back.
- DO NOT USE A REAR FACING CHILD RESTRAINT WHERE AN AIRBAG IS FITTED IN FRONT OF THE SEATING POSITION.
- Do not harness an infant wrapped in a blanket or swaddled. Any blanket or wrap must only be placed over the harness and infant.

VERY IMPORTANT: Only replace the cover with a Joie supplied replacement cover with identical shoulder height markers or a replacement cover meeting AS/NZS 8005.

NOTE: The warnings on this page are required by the Australian and New Zealand Standard AS/NZS 1754 for this type of child restraint. Other warnings specific to this particular child restraint will be found on the following pages and throughout these instructions.

ADDITIONAL WARNINGS

This Child Restraint is: **To be used only in a rearward-facing position until the infant's shoulders either reach the lower shoulder height marker (approximately 12 months of age) or reach the middle height marker (approximately 2 to 3 years of age).**

Then to be used in a forward-facing position until the child's shoulders reach the upper shoulder height marker (approximately 4 years of age).

Continue to use this child restraint until the child reaches this limit.

Do not use forward facing until child's shoulders are above the lower shoulder height marker.

Infants are at risk of serious injury if they face forward too early.

Children are at risk of serious injury if they move to booster seats too early.

Children who have outgrown this restraint are safest in a larger child restraint with an in-built harness, or a booster seat until their shoulders reach the upper shoulder height marker of the restraint.

Ensure that children have adequate ventilation and shade when in the vehicle.

Strangulation hazard: Child can strangle in loose restraint straps. Always use harness. Never leave child in restraint when straps are loose or undone.

Follow the instructions on pages 17 & 18 for use of the liner.

Aftermarket accessories (i.e. items not provided in the box with the child restraint), may not have been tested for use with this child restraint and if used, may lower the level of protection offered possibly leading to injury or death.

Any aftermarket accessory used should be compliant with AS/NZS 8005 (Accessories for child restraints for use in motor vehicles) and stated as suitable for use with this child restraint.

ADDITIONAL WARNINGS

Only install child restraint in a forward facing vehicle seat. Never install in a seat that faces the rear or the side of the vehicle.

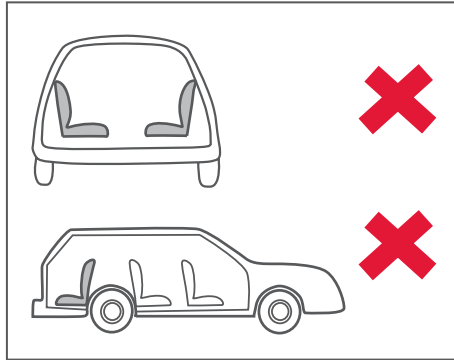

Never install the Child Restraint in a seat with a front airbag. DEATH or SERIOUS INJURY may occur. Refer to your vehicle Owners Manual for airbag warnings and information.



Features

- | | | | |
|---|---------------------------------|----|--|
| 1 | Headrest height Adjustor | 7 | Crotch Pad |
| 2 | Seat Cover | 8 | Shoulder Harness Strap |
| 3 | Harness QR Buckle | 9 | Shoulder Harness Strap Cover |
| 4 | Harness Adjuster (under cover) | 10 | Infant Body Support |
| 5 | Harness Adjuster Webbing | 11 | ISOFIX compatible connector strap storage pocket |
| 6 | Recline Angle Adjustment Handle | | |

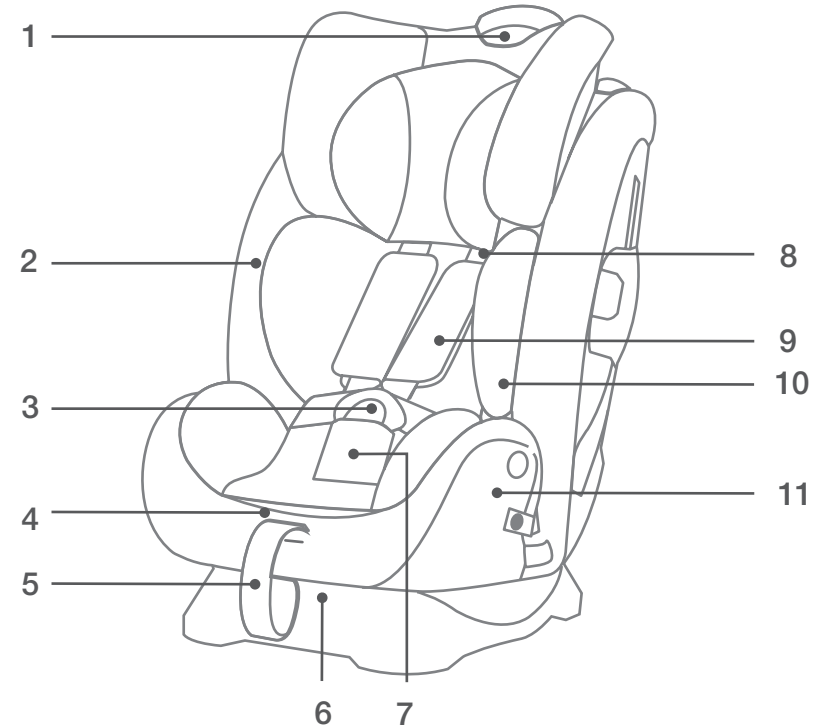

Features

- | | | | |
|----|------------------------------|----|--|
| 12 | Top Tether Anchorage | 19 | Top Tether End Storage Bag |
| 13 | Top Tether | 20 | Seat Shell |
| 14 | Head Support Adjuster Handle | 21 | Forward-Facing Vehicle Belt Slot |
| 15 | Sash Belt Lock-off Device | 22 | Rear-Facing Vehicle Belt Slot |
| 16 | Extra side impact protection | 23 | ISOFIX compatible connector strap storage pocket |
| 17 | Instructions Storage | | |
| 18 | Base | | |

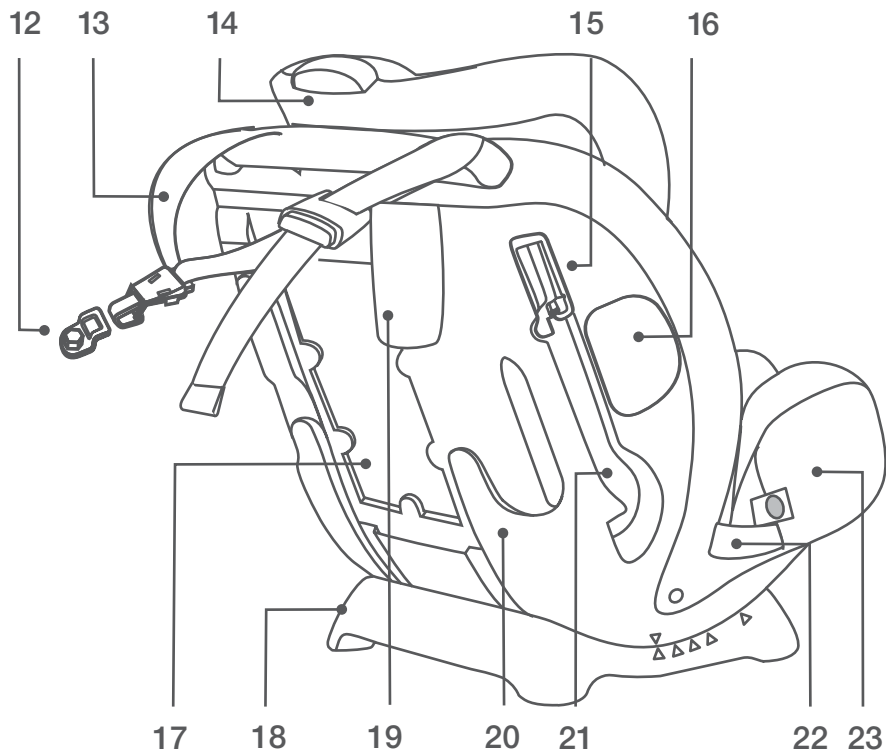

Securing a Child in the Restraint - Recline Angle

This restraint should be installed in the rear seat. See Installation instructions.

Correct Recline Angle

When used rear facing the restraint must always be fully reclined. The white arrow on the shell must be above the blue arrow on the base.

IMPORTANT: A correct recline angle is essential for your baby's safety.

To Adjust:

1. Pull the release handle on the shell fully forward.

2. Rotate the shell until the white arrow is above the blue arrow.

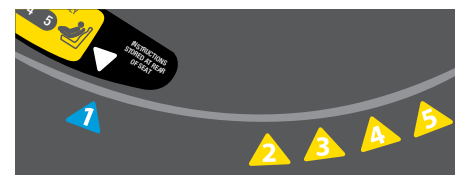
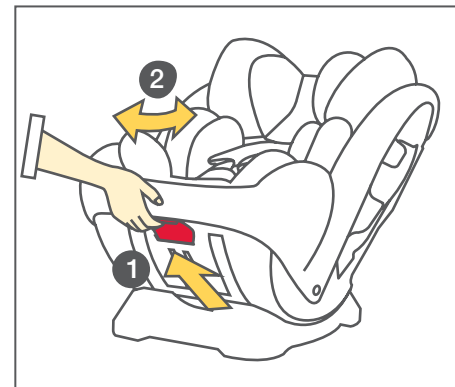
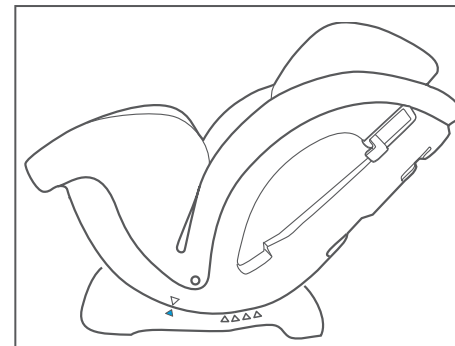

Securing a Child in the Restraint - Shoulder Strap height labels

This restraint has a shoulder height level label. Use this label to decide if the restraint should be rear or forward facing.

If your child's shoulders are below the bottom dotted line **A** the restraint must be rearfacing. Once your child's shoulders pass the line **A** they can be either rearfacing or forward facing. Once your child's shoulders reach the dotted line **B** the restraint must be forward facing. See page 20 for information about forward facing use.

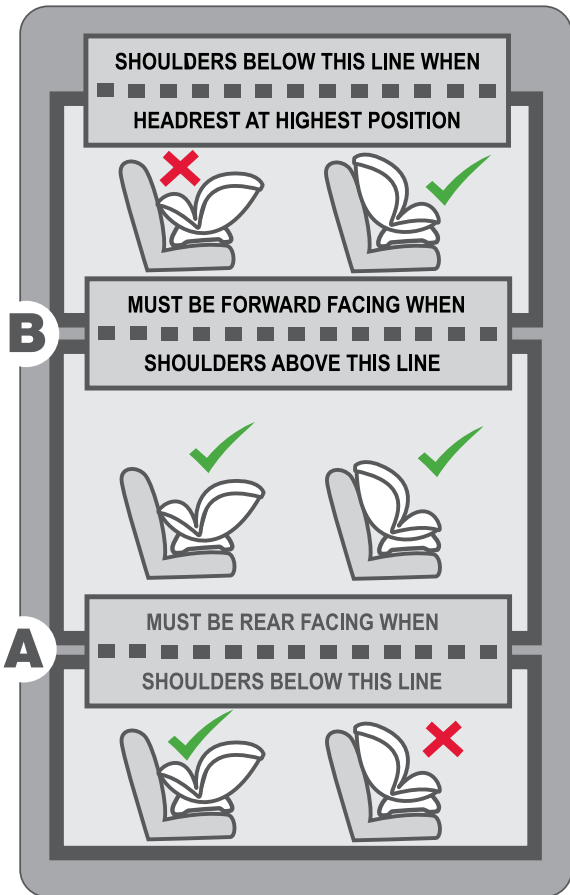

IMPORTANT: Children are safer rear facing. Joie recommends that they remain rear facing until their shoulders reach line B

Securing a Child in the Restraint - Shoulder Strap height

Correct positioning of the shoulder straps is essential for your baby's safety.

Requirement:
The shoulder straps must be positioned near to the child's shoulders, but not lower than the child's shoulders. The straps should be in the next available adjustment position above your child's shoulders.

Note: the shoulder strap height requirement rear facing is different to forward facing. See page 20 for forward facing.

To Check:
With baby placed in the restraint, note where the shoulder straps are positioned relative to the shoulders.

To Adjust:
If adjustment is needed squeeze the headrest adjustor handle and raise or lower the headrest and shoulder straps as required.

IMPORTANT: Always adjust the height of the shoulder straps as the child grows

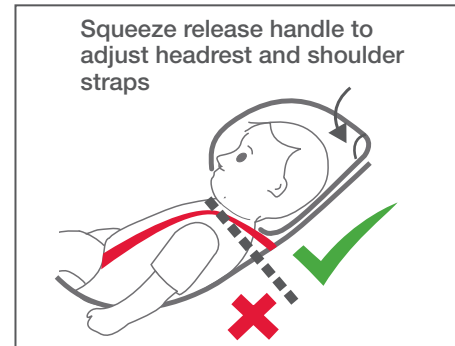
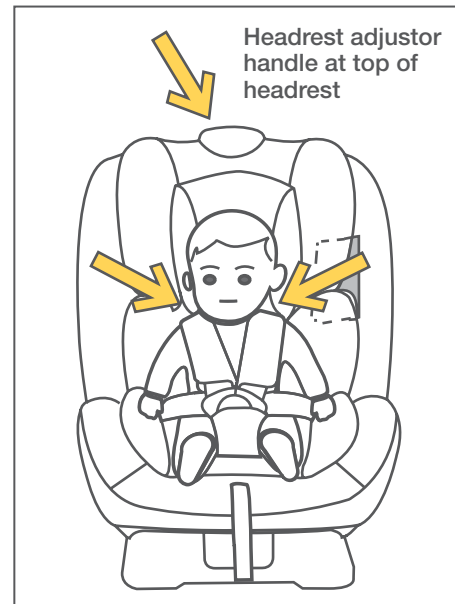

Securing a Child in the Restraint - Using the Harness

FIRST CHECK SHOULDER STRAP HEIGHT AND ADJUST IF NECESSARY. See page 11.

1. Loosen harness by pressing on adjuster button A while pulling on the harness straps B.



2. Press button to open the quick release buckle. Spread harness straps apart.

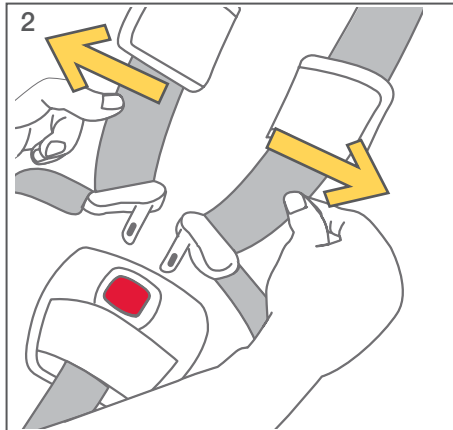

Securing a Child in the Restraint - Using the Harness

3. Place child in restraint in seated position.

IMPORTANT:
Child must be dressed in clothing that allows the harness to firmly secure them. See page 16.

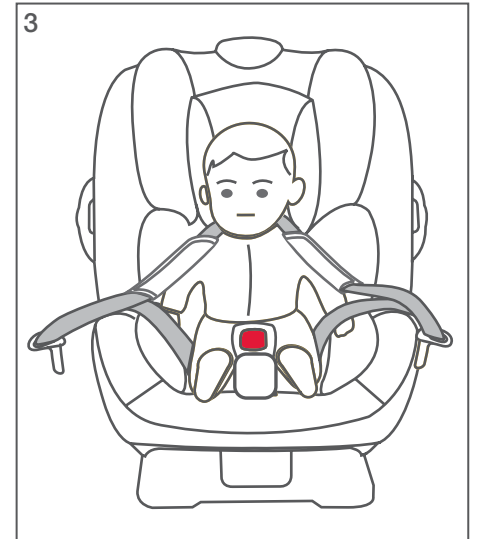

4. Child must be placed firmly against both the back and bottom of the seating surface.

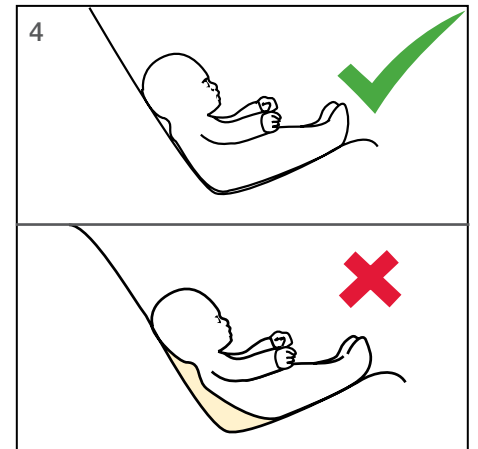

Securing a Child in the Restraint - Using the Harness

5. Place buckle tongues into the quick release buckle.

IMPORTANT

The buckle tongue pushed in last should “CLICK” when it locks into place. If it does not click, try again or try cleaning the buckle. See page 30.

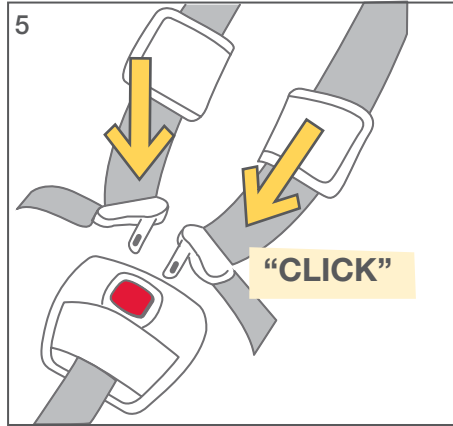

6. Make sure there are no twists in the straps.

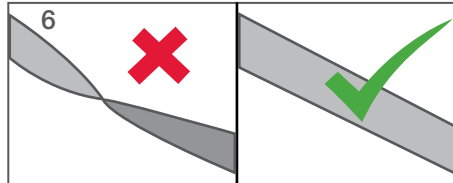

7. Recheck shoulder strap height. See page 11.

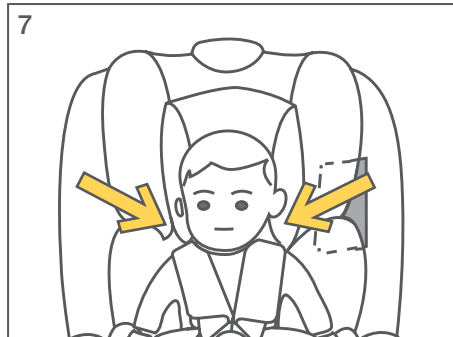

Securing a Child in the Restraint - Adjusting the Harness

8. Tighten harness by pulling on the adjuster strap at the front of the restraint.

Shoulder straps should be a snug fit.

Note: sometimes the straps may be loose in the lap part of the harness.

You may need to pull loose straps through the buckle tongues upward towards the child’s shoulder and then pull again on the adjuster strap.

This may need to be repeated several times to get a snug fit.

9. Correct strap tension.

Put a finger under each strap and pull gently outwards.

There should be no gap between your finger and the baby.

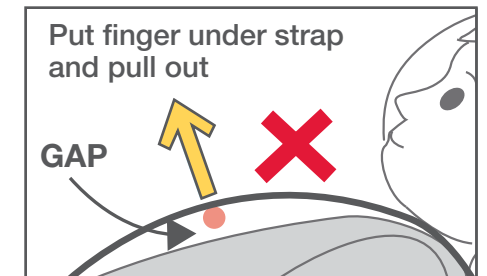
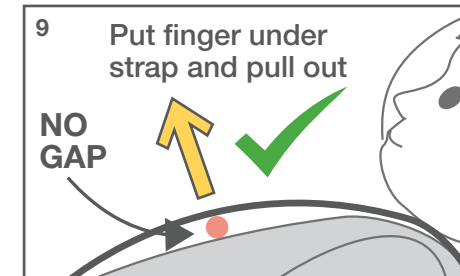
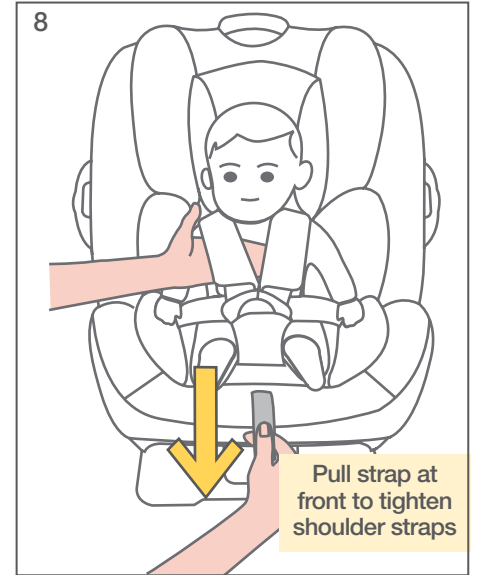

Securing a Child in the Restraint - CHECKLIST

Checklist

1. Shoulder straps at correct height
2. No straps twisted
3. Shoulder straps snug
4. If tether strap has been moved out of the way - reconnect it.

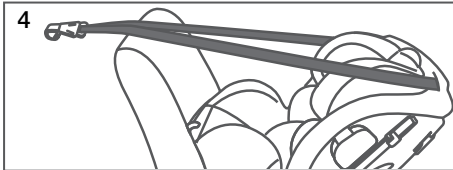
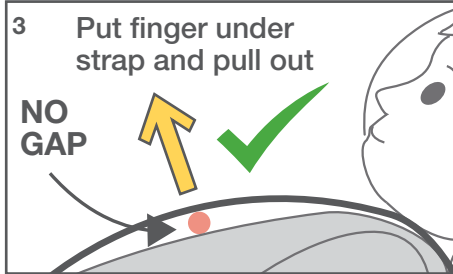
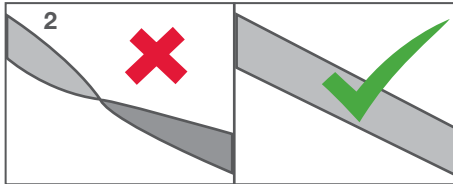
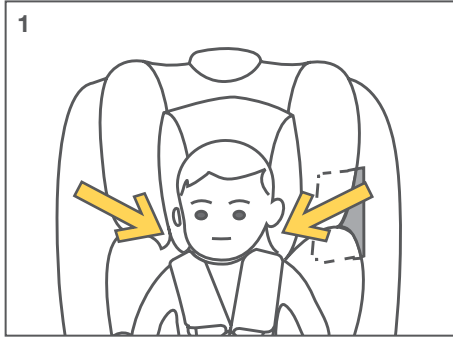

IMPORTANT

Infants need to be securely held by the harness. An infant wrapped in a blanket or swaddled will not be securely held and may be ejected and killed in an accident.

The harness needs to fit the infant securely.

Only place any blanket or other covering over the harness after it is adjusted.

Do not bind or wrap the infants arms or legs together.



WARNING

DO NOT LEAVE CHILDREN UNATTENDED IN THE CAR

Liner

Rear Facing

This restraint has a soft padded liner for use with a baby or small child. Use this liner for more comfort or if they are not fully supported by the main cover.



Removable Head Support

The head support is attached to the main liner by snaps and can be removed. Remove the head support when the child's head no longer fits comfortably inside the headrest.

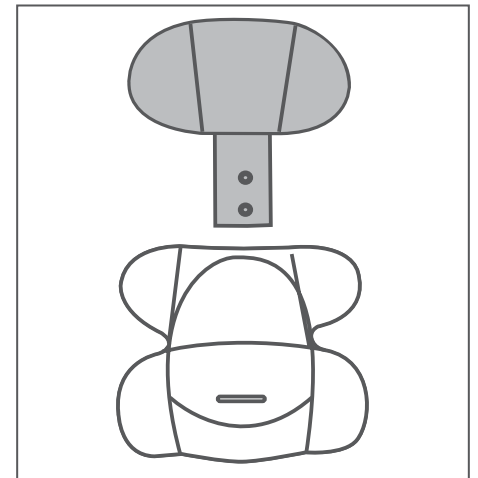

The body portion of the liner can be used separate from the head support.

Shoulder, Lap and Crotch pads.

These are for comfort only and can be removed at any time.

Liner

Forward Facing

The liner should be used for small children only.

It should be removed when they grow older than about 6 months.

DO NOT use the liner if the child is so big that it is preventing them having some movement.

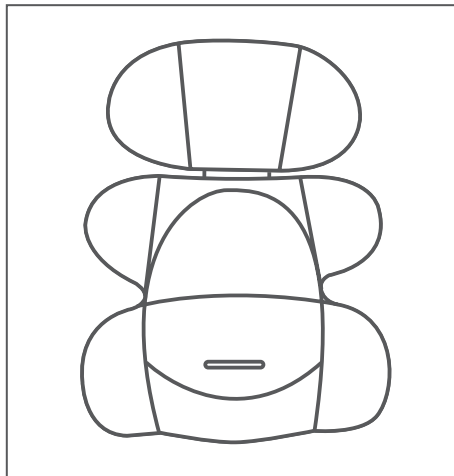

Securing a Child in the Restraint - Recline Angle

Correct Recline Angle

When used forward facing the restraint must always be correctly reclined. The white arrow on the shell must be above one of the yellow arrows on the base.

Select a position that gives the most comfort for your child.

IMPORTANT A correct recline angle is essential for your child's safety.

DO NOT use the position marked by the blue arrow when the restraint is forward facing.

To Adjust:

1. Pull the release handle on the shell fully forward.

2. Rotate the shell until the white arrow is above one of the yellow arrows.

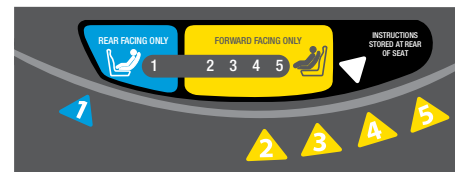
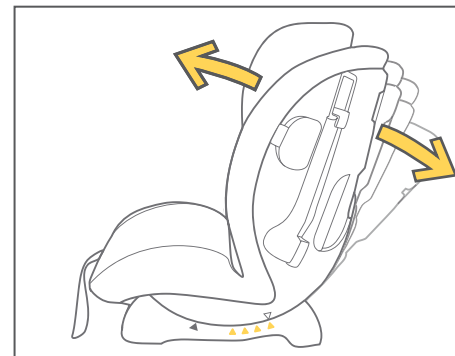

Securing a Child in the Restraint - Shoulder Strap height labels

This restraint has a shoulder height level label.

Use this label to decide if the restraint should be rear or forward facing.

If your child's shoulders are below the bottom dotted line **A** the restraint must be rear-facing.

Once your child's shoulders pass the line **A** they can be either rearfacing or forward facing.

Once your child's shoulders reach the dotted line **B** the restraint must be forward facing.

Once your child passes line **C** they are too big for this restraint and need to move to a Booster Seat.

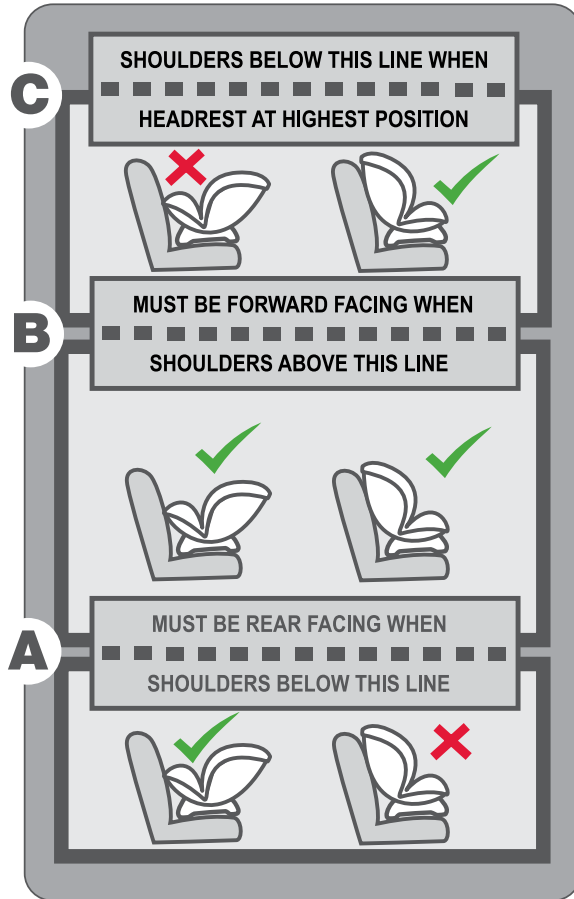
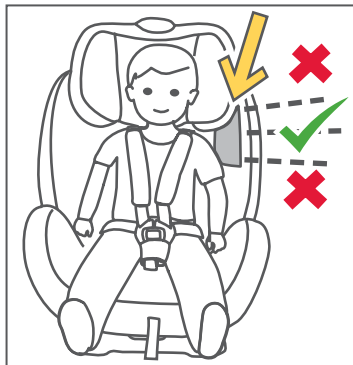

IMPORTANT: Joie recommends that children remain rear facing until their shoulders reach line B.

Securing a Child in the Restraint - Shoulder Strap height

Correct positioning of the shoulder straps is essential for your child's safety.

Requirement:

The shoulder straps must be positioned near to the child's shoulders, but not more than 25 mm below the child's shoulders.

Note: the shoulder strap height requirement forward facing is different to rear facing. See page 11 for rear facing.

To Check:

With child placed in the restraint, note where the shoulder straps are positioned relative to the shoulders.

To Adjust:

If adjustment is needed squeeze the headrest adjustor handle and raise or lower the headrest and shoulder straps as required.

IMPORTANT: Always adjust the height of the shoulder straps as the child grows

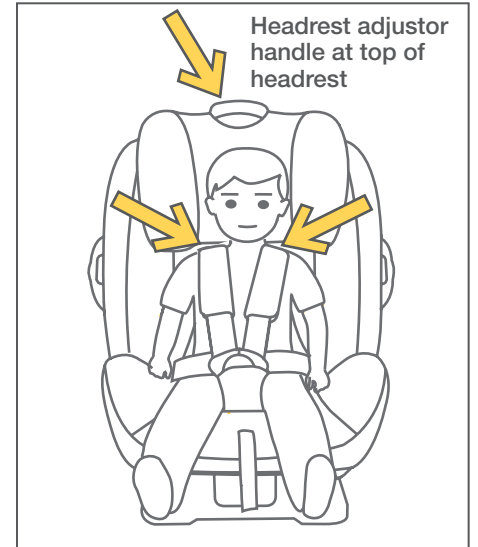

Squeeze release handle to adjust headrest and shoulder straps

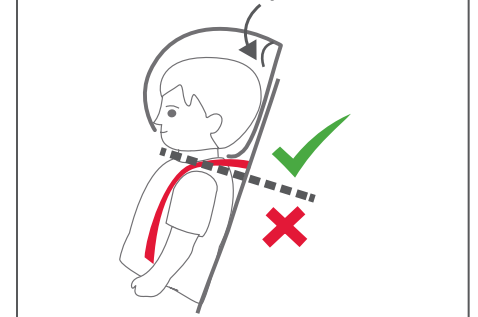

Securing a Child in the Restraint - Securing the Harness

FIRST CHECK SHOULDER STRAP HEIGHT AND ADJUST IF NECESSARY. See page 26.

1 Loosen harness by pressing on adjuster button A while pulling on the harness straps B.



2 Press button to open the quick release buckle.

Spread harness straps apart.

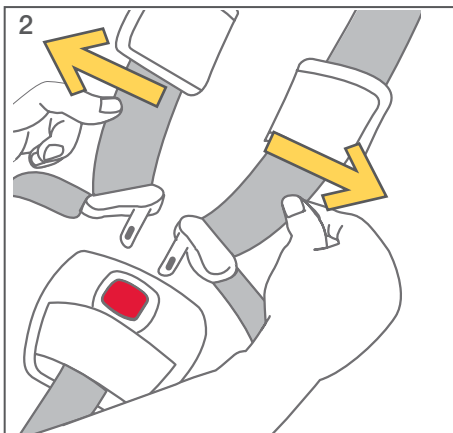

Securing a Child in the Restraint - Securing the Harness

3 Place child in restraint in seated position firmly against both the back and bottom of the restraint.

IMPORTANT

Children need to be securely held by the harness. Children must be dressed in clothing that allows the harness to firmly grip them. Do not wrap the child in a blanket or similar. Only place such covering over the child after they are strapped in.

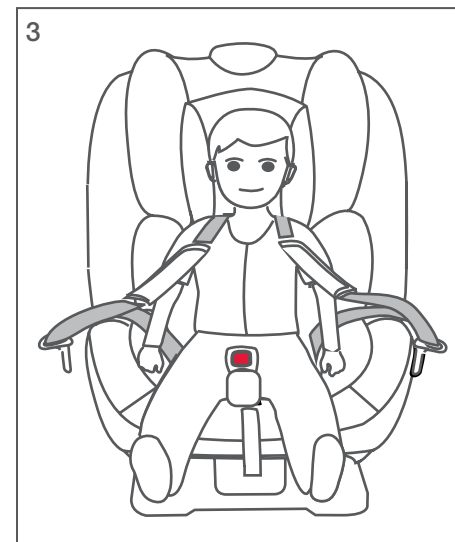

4 Place buckle tongues into the quick release buckle.

IMPORTANT:

The buckle tongue pushed in last should "CLICK" when it locks into place. If it does not click, try again or try cleaning the buckle. See page 30

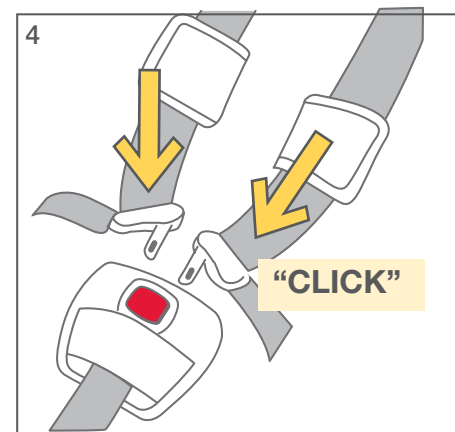

Securing a Child in the Restraint - Adjusting the Harness

6. Make sure there are no twists in the straps.

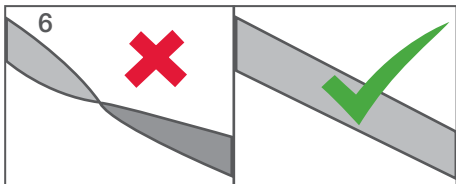

7. Recheck shoulder strap height. See page 21.

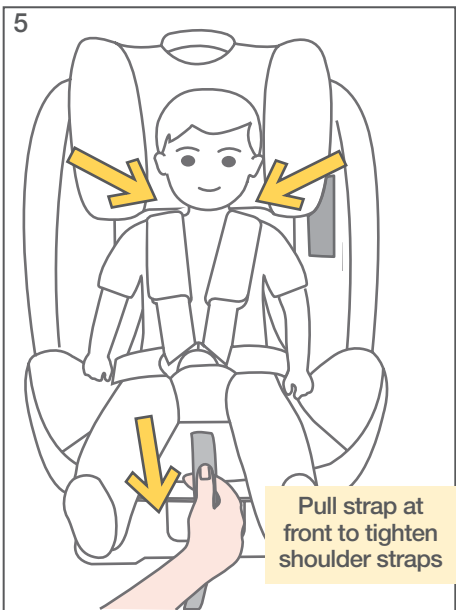

5 Tighten harness by pulling on the adjuster strap at the front of the restraint.

Note: the lower harness webbing may not pull freely through the harness buckle tongues.

You may need to pull the webbing through the buckle tongues up towards the child's shoulder then pull on the adjuster strap again.

This may need to be repeated several times to get the webbing fitting snugly.



WARNING

DO NOT LEAVE CHILDREN UNATTENDED IN THE CAR

Securing a Child in the Restraint - Adjusting the Harness

9. Correct strap tension.

Put a finger under each strap and pull gently outwards. There should be no gap between your finger and the child.

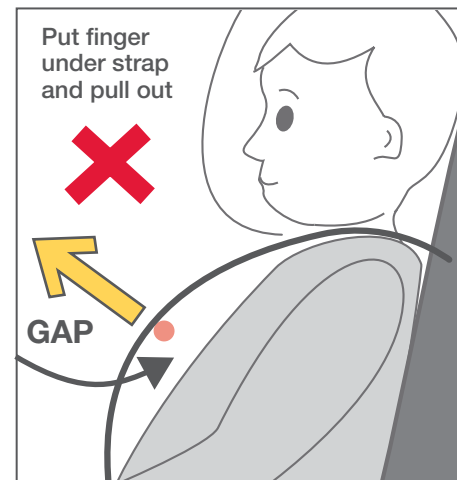
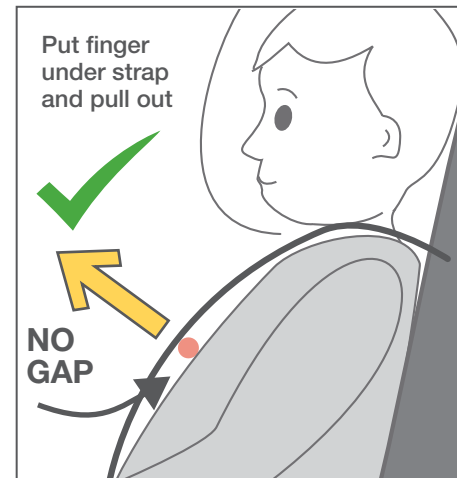

Securing a Child in the Restraint - CHECKLIST

Checklist

1. Shoulder straps at correct height
2. No straps twisted
3. Shoulder straps snug

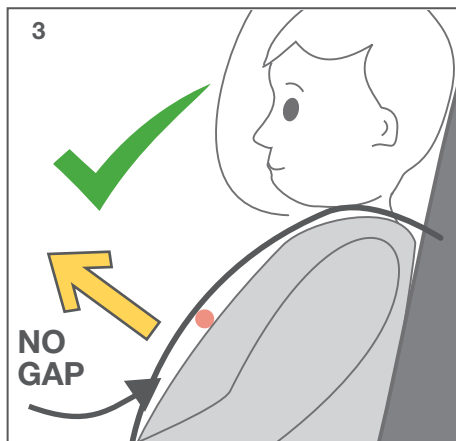
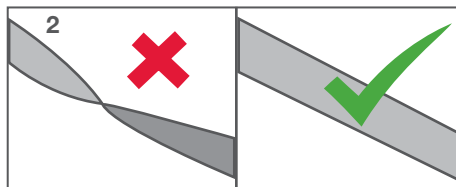

Cover Removal

To Remove

1. Remove the Infant Insert, Shoulder Pads and Crotch Pad if fitted,

Headrest cover

2. Detach elastic loop fasteners at back of headrest and remove the head support cover by pulling forward over the headrest.

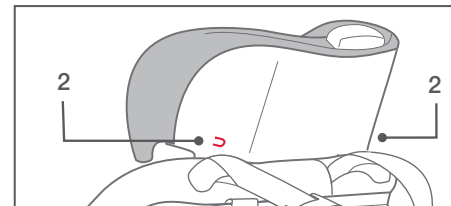

Seat Cover

3. Take the ISOFIX compatible connectors out of their storage pockets,
4. Press the red button down to disengage the QR buckle and remove webbing and spread outwards,
5. Detach the press studs on sides of seat pad.
6. Detach the press studs inside the cover.
7. Pull the QR buckle through the slot in the seat pad and then remove seat pad from seat shell.

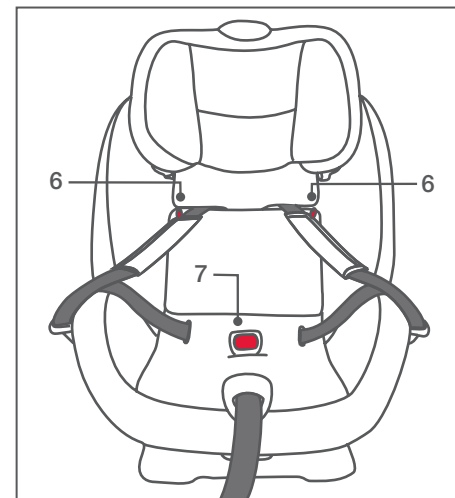
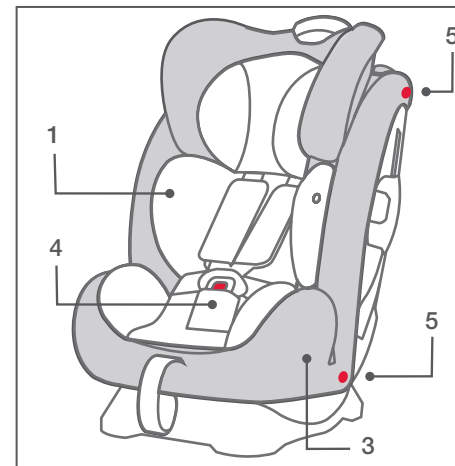

REAR FACING USE

FORWARD FACING USE

Refit Cover

To Refit

Seat Cover

1. Place the main cover into the seat.
2. Thread the QR buckle through the slot in the cover, and move the harness lap straps into the slots in the cover.
3. Secure the press studs inside and outside the shell.
4. Replace the ISOFIX compatible connectors in their storage pockets,
5. Replace the infant Insert and crotch pad if using these items.

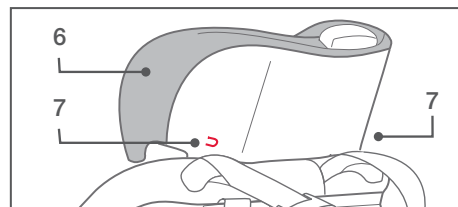
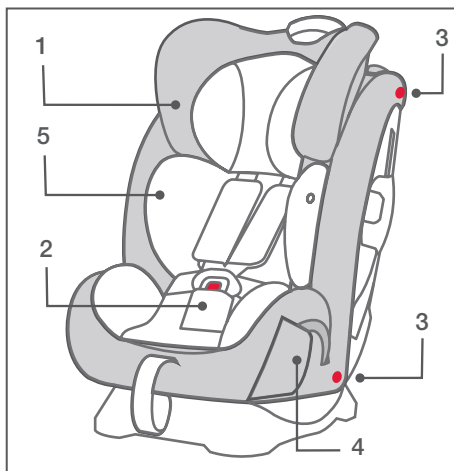

Headrest Cover

6. Pull the headrest cover over the headrest from the front.
7. Locate the elastic loops and thread these under the headrest and reattach to the lugs at the back of the headrest.

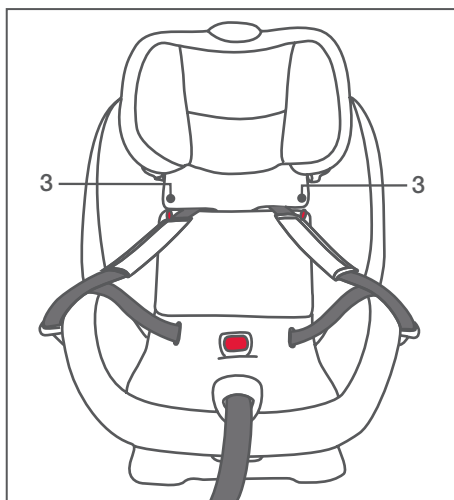

The Next Restraint

This restraint is suitable for a child of average size up to approximately four years of age.

When the child has outgrown this restraint, the next suitable types of restraint are a bigger harnessed seat or a booster seat.

Some harnessed seats are suitable for children up to approximately 8 years of age.

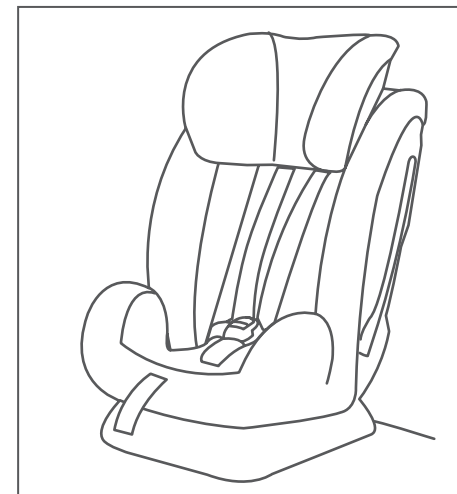

Booster seats are available for children up to approximately 8 or 10 years of age.

Illustrated: Joie Trillo

IMPORTANT: Children are at risk of serious injury if they move to booster seats too early.

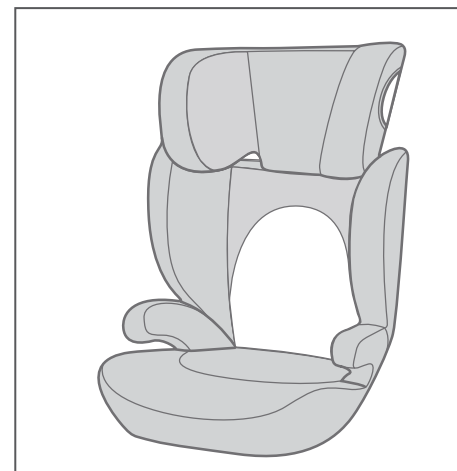

Maintenance

SEAT COVER

Wash with cold water at less than 30 degrees C.

Do not iron.

Do not bleach or dry clean.

Do not twist the soft goods to dry with great force. It may leave the seat cover with wrinkles.

Hang dry the seat cover in the shade. Do not tumble dry.

PLASTIC AND METAL PARTS

Use only mild detergent, water and a soft cloth to clean the car seat shell, handle and harness straps. Air dry.

Do not use undiluted detergent, or other solvents to clean - these may cause damage.

HARNESS STRAPS

Shoulder harness straps are not removable.

Clean with mild detergent, water and a soft cloth only.

HARNESS BUCKLE

To clean the buckle: rinse using warm water. DO NOT use any soaps, solvents or lubricants. Using anything other than water can cause the buckle to malfunction. Air dry.

When the buckle is operating correctly the tongues will push in easily and the second tongue will CLICK when it latches into place.

If the buckle does not appear to be working correctly get it checked or replaced by contacting the retailer from where it was purchased, or by contacting Australia's Power Brands.

STORAGE

Remove the child restraint from the vehicle seat if not in use for a long period of time. Put the child restraint in a cool, dry place where your child cannot access it.