

bright
by **Joie™**

banksia™

MODEL BC2408

instruction manual



IMPORTANT: KEEP THIS INSTRUCTION BOOKLET IN THE
PLACE PROVIDED AT THE BACK OF THE CHILD RESTRAINT

Keep these Instructions for future reference

IMPORTANT:

Before installation and use of this child restraint check that it is suitable for the size of your child.

Refer to the shoulder height label information on pages 28 and 36.

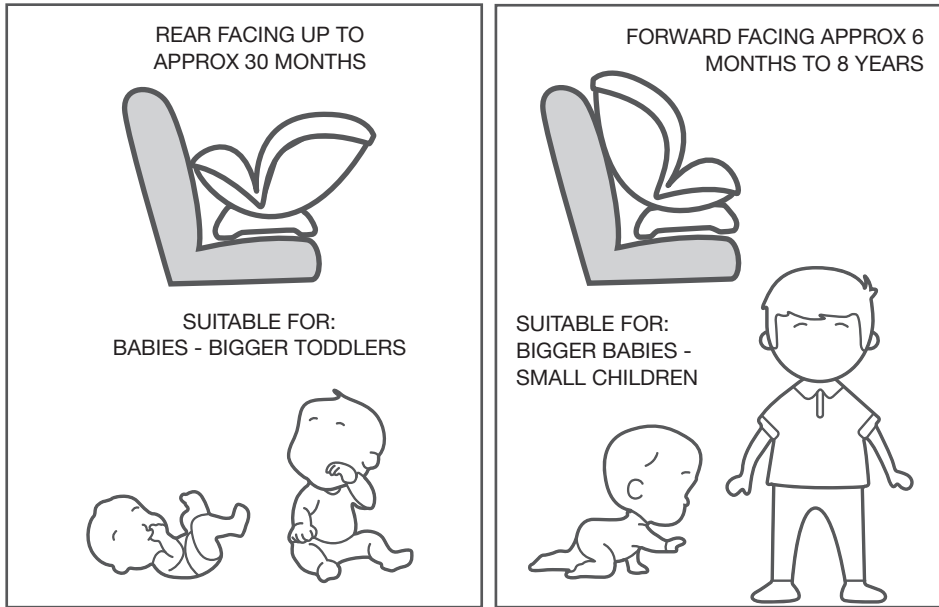

DO NOT USE THIS CHILD RESTRAINT UNTIL YOU HAVE READ AND UNDERSTOOD THE INSTRUCTIONS IN THIS USER GUIDE AND IN YOUR VEHICLE OWNERS MANUAL

Read the whole of these instructions carefully and if there is any doubt about the method of installation, consult the child restraint manufacturer or agent, or a child restraint fitting station authorized by the relevant transport authority, or in New Zealand an agent for the vehicle.

CONTENTS

WARNINGS 4

ADDITIONAL WARNINGS 5 - 7

Features 8 & 9

REAR FACING INSTALLATION

Recline Angle 10

Installing the Restraint 11 - 14

CHECKLIST 15

FORWARD FACING INSTALLATION

Recline Angle 16

Installing the Restraint 17 - 20

CHECKLIST 21

TOP TETHER WARNINGS 22

Top Tether Features 23

Tether Anchorage Installation 24 - 26

REAR FACING

Recline Angle 27

Shoulder Strap Height Labels 28

Shoulder Strap Height 29

Using the Harness 30 - 32

Adjusting the Harness 33

CHECKLIST 34

FORWARD FACING

Recline Angle 35

Shoulder Strap Height Labels 36

Shoulder Strap Height 37

Using the Harness 38 & 39

Adjusting the Harness 40 & 41

CHECKLIST 42

Liner 43

Cover Removal & Refit 44 & 45

Cleaning and Maintenance 46

The Next Restraint 47

WARNINGS

- Use the restraint exactly as shown in the instructions.
- Supervision of children is needed because they may be able to undo buckles.
- A loose harness or restraint is dangerous.
- Fit the harness firmly to the child.
- **DO NOT USE THIS RESTRAINT WITHOUT THE COVER**
- To ensure that infant's back is evenly supported, do not put more than one nappy on the baby and make sure the nappy is not folded thickly at the back.
- Do not harness an infant wrapped in a blanket or swaddled. Any blanket or wrap must only be placed over the harness and infant
- Do not alter or modify this restraint.
- Repairs must only be done by the manufacturer or agent.
- Do not allow the restraint to come into contact with polishes, oils, bleach and other chemicals.
- Destroy the restraint if it has been in a severe crash, even if no damage is visible.
- A loose harness or restraint is dangerous.
- Fit the restraint firmly to the car seat.
- **DO NOT USE A REAR FACING CHILD RESTRAINT WHERE AN AIRBAG IS FITTED IN FRONT OF THE SEATING POSITION.**
- This child restraint is not approved for use with any connectors that connect to the car's ISOFIX low anchorages.
- **DO NOT LEAVE CHILDREN UNATTENDED IN THE CAR**

NOTE: The warnings on this page are required by the Australian and New Zealand Standard AS/NZS 1754 for this type of child restraint. Other warnings specific to this particular child restraint will be found on the following pages and throughout these instructions.

ADDITIONAL WARNINGS

This Child Restraint is: **To be used only in a rearward-facing position until the infant's shoulders either reach the lower shoulder height marker (approximately 12 months of age) or reach the middle height marker (approximately 2 to 3 years of age).**
Then to be used in a forward-facing position until the child's shoulders reach the upper shoulder height marker (approximately 8 years of age).

Continue to use this child restraint until the child reaches this limit.

Do not use forward facing until child's shoulders are above the lower shoulder height marker.

Infants are at risk of serious injury if they face forward too early.

Children are at risk of serious injury if they move to booster seats too early.

Just using a seatbelt is not recommended for children that have outgrown this restraint. Children are safest in a booster seat until their shoulders reach the upper shoulder height marker of the booster seat

TO BE USED WITH A LAP-SASH/LAP ONLY SEAT BELT IN THE BACK OF MOST CARS WITH FORWARD FACING SEATS.

DO NOT ATTACH THIS CHILD RESTRAINT TO ANY ISOFIX LOW ANCHORAGE. ISOFIX low anchorages in cars are designed to withstand only those loads imposed by children aged up to approximately 4 years of age in a correctly fitted and approved ISOFIX compatible child restraint. This child restraint is not approved for use with the car's ISOFIX low anchorages

Ensure that children have adequate ventilation and shade when in the vehicle.
Strangulation hazard: Child can strangle in loose restraint straps. Always use harness. Never leave child in restraint when straps are loose or undone.

Follow the instructions for use of the liner.

ADDITIONAL WARNINGS

Do not use seat belt extenders if the car seat belt is not long enough to secure the child restraint. If the vehicle seat belt is not long enough to secure the restraint seek advice from a child restraint fitter.

Read carefully the whole of the instructions for the installation, and in the event of doubt about the method of installation, consult the child restraint manufacturer or agent, or a child restraint fitting station authorized by the relevant transport authority, or in New Zealand, consult the agent for the vehicle.

Aftermarket accessories (i.e. items not provided in the box with the child restraint), may not have been tested for use with this child restraint and if used, may lower the level of protection offered possibly leading to injury or death.

Any aftermarket accessory used should be compliant with AS/NZS 8005 (Accessories for child restraints for use in motor vehicles) and stated as suitable for use with this child restraint.

When installed rearward facing this restraint is 610 mm long, 460 mm wide and 515 mm high. Check the measurement between the front of the seat back of the rear seat and all front seats in the car in which the restraint is intended to be used to ensure the space available is sufficient.

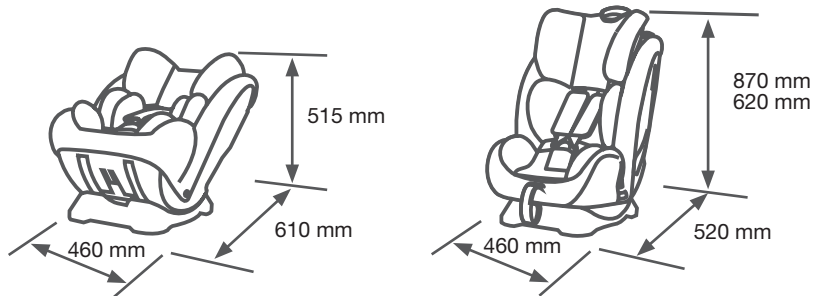

ADDITIONAL WARNINGS

Only install child restraint in a forward facing vehicle seat. Never install in a seat that faces the rear or the side of the vehicle.

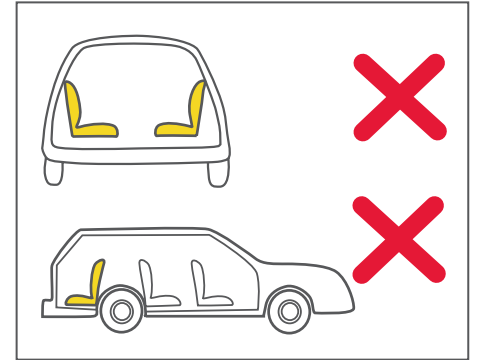

Never install the Child Restraint in a seat with a front airbag. DEATH or SERIOUS INJURY may occur. Refer to your vehicle Owners Manual for airbag warnings and information.



IMPORTANT

Some vehicles have airbags attached to the sash belt. DO NOT install the restraint using this type of belt. If in doubt refer to the vehicle owners manual or an approved child restraint fitter.

Features

- | | | | |
|---|--------------------------------|----|---------------------------------|
| 1 | Headrest height Adjustor | 6 | Recline Angle Adjustment Handle |
| 2 | Seat Cover | 7 | Crotch Pad |
| 3 | Harness QR Buckle | 8 | Shoulder Harness Strap |
| 4 | Harness Adjuster (under cover) | 9 | Shoulder Harness Strap Cover |
| 5 | Harness Adjuster Webbing | 10 | Infant Body Support |



Features

- | | | | |
|----|---------------------------|----|----------------------------------|
| 11 | Top Tether Anchorage | 17 | Base |
| 12 | Top Tether Snap Hook | 18 | Tether End Storage Bag |
| 13 | Top Tether | 19 | Seat Shell |
| 14 | Headrest Adjuster | 20 | Forward-Facing Vehicle Belt Slot |
| 15 | Sash Belt Lock-off Device | 21 | Rear-Facing Vehicle Belt Slot |
| 16 | Instructions Storage | | |

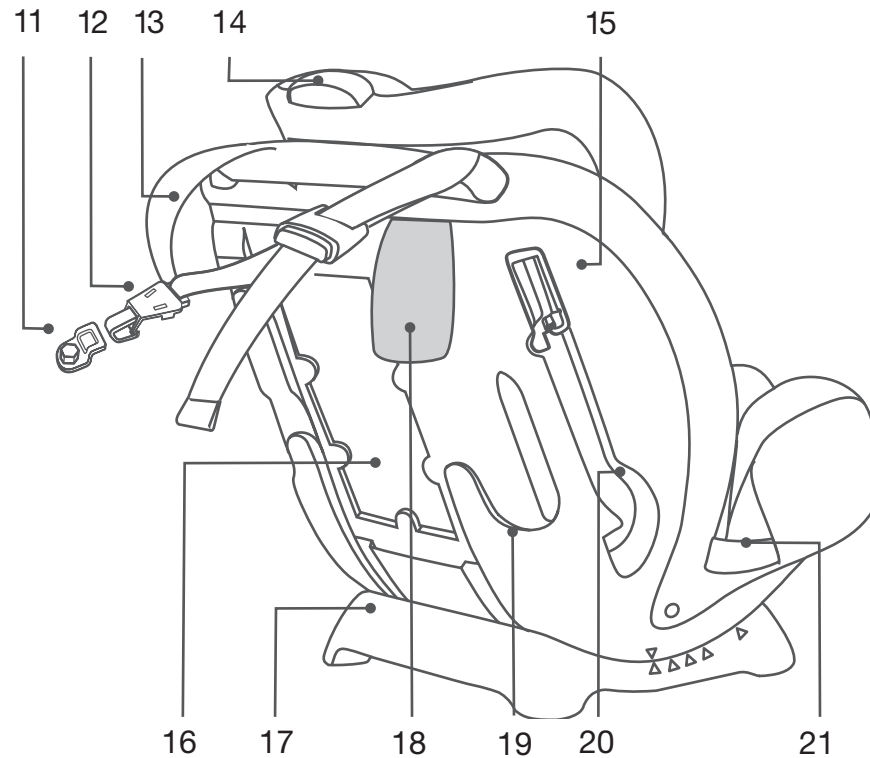

Recline Angle

This restraint should be installed in the rear seat.

Correct Recline Angle

When used rear facing the restraint must always be fully reclined. The white arrow on the shell must be above the blue arrow on the base.

IMPORTANT: A correct recline angle is essential for your baby's safety.

To Adjust:

1. Pull the release handle on the shell fully forward.

2. Rotate the shell until the white arrow is above the blue arrow.

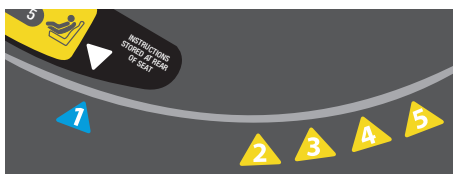
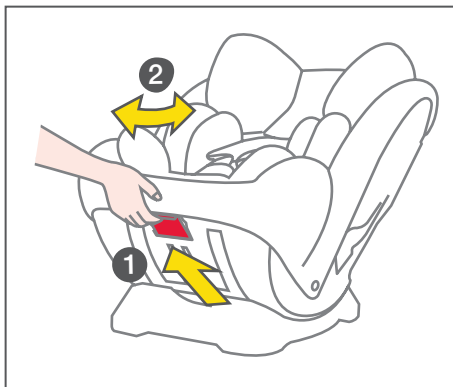
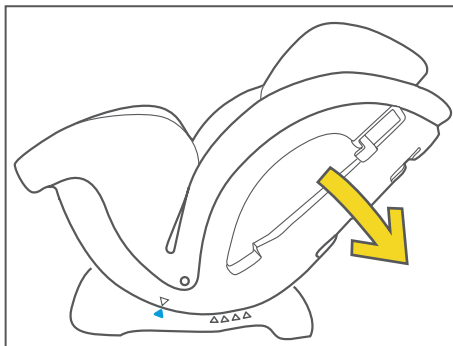

Installation

Place the restraint on the vehicle seat rear facing.

See page 7 for recommended positions in the vehicle.

1. Pull the vehicle lap/sash belt out and pass through the slot in the restraint.

Pass the vehicle belts over the restraint seating surface and out the other side.

2. Engage the vehicle belt buckle.

REARWARD FACING BELT PATH

Look for this label showing the correct path for the vehicle belts

REARWARD FACING BELT PATH

IMPORTANT: the vehicle belts must be fully down in the slots in the side wings

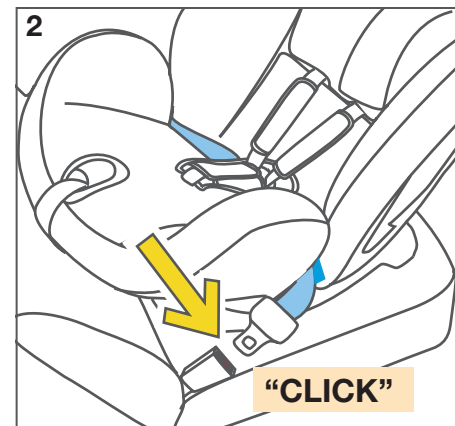
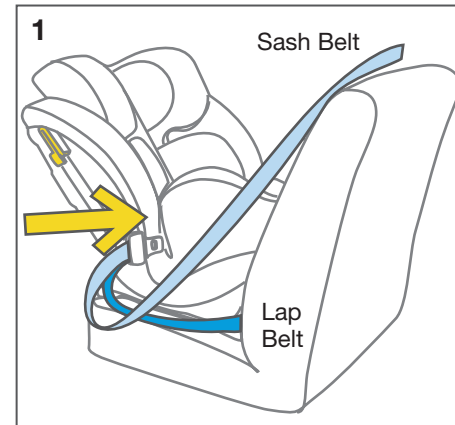
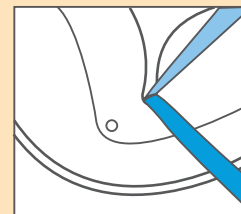

Installation

3. Pull the vehicle belts tight.

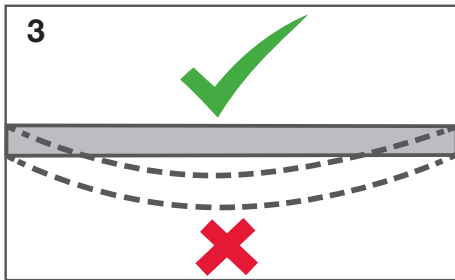

4. Ensure there are no twists in the belts.

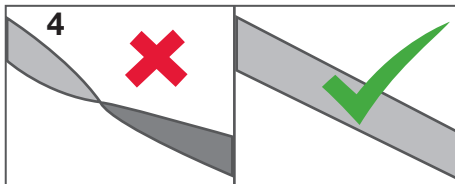

5. Connect the top tether strap.

NOTE: many vehicles have built-in top tether connection points. If your vehicle does not have these refer to page 25 for information on fitting the anchorage supplied.

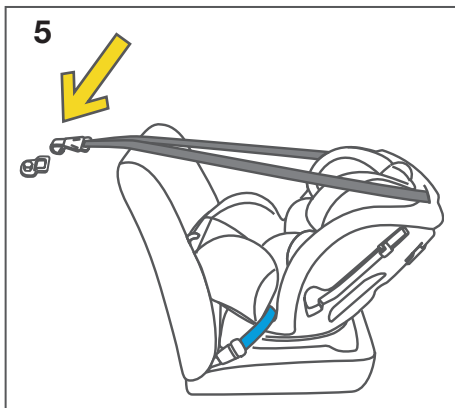

Installation

6. Store end of web in bag on back of cover.

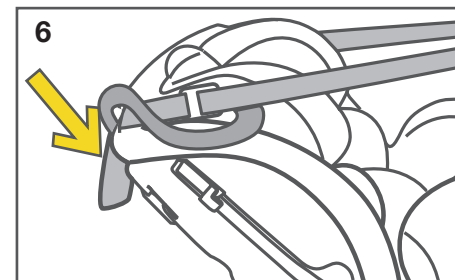

Tether Strap General Information

Also refer to page 23 for more Top Tether information.

Always connect the snap hook securely to the anchorage fitting.

Increase tether tension by pulling web out.

If the web is hard to pull through the adjuster also press the release button.

Reduce tension by pressing release button and pulling web out.

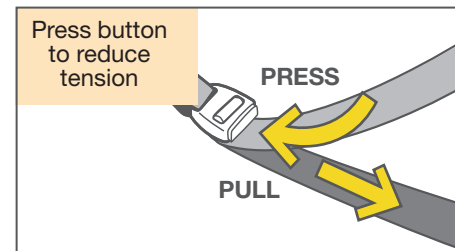
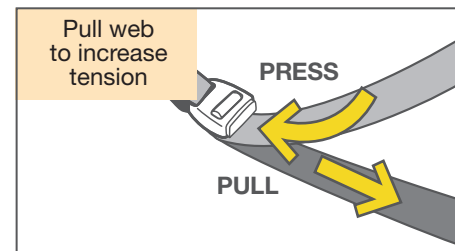
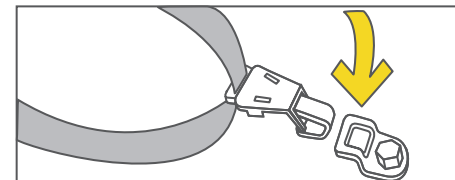

Installation

Straps must not be twisted.

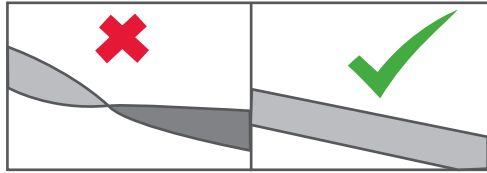

Pull straps pulled tight.

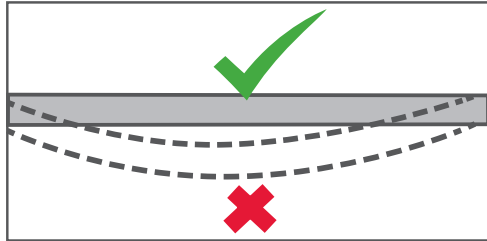

Adjust the tether tension until the tether is pulled tight.

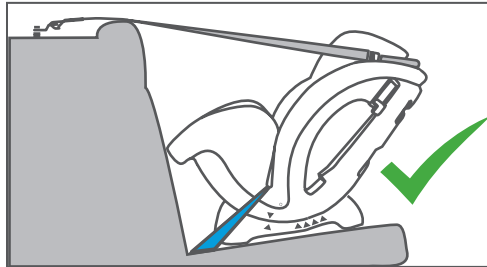

Do not adjust so tight that it lifts the child restraint off the vehicle seat.

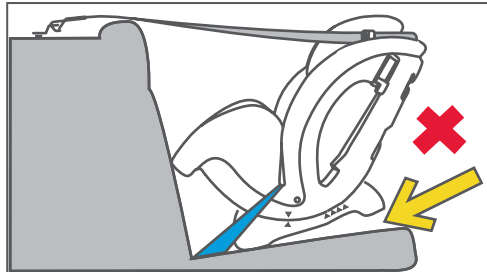

Checklist

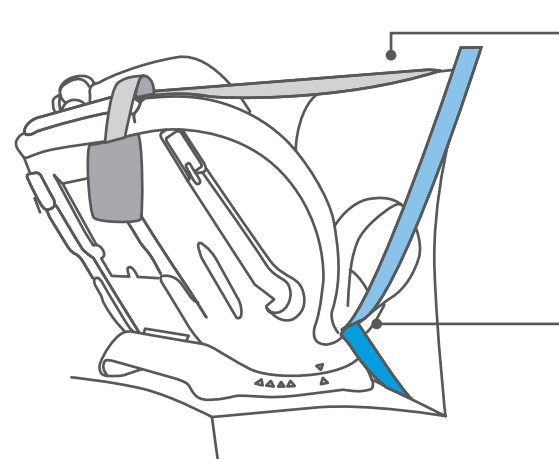

Tether Strap - check tension. Ensure there are no twists in the webbing. End of tether in storage bag

Sash Belt - fully down in the side slots

Tether Strap - securely attached to anchorage

Vehicle Belt - latched securely and pulled tight

Recline adjustment - restraint must be fully reclined

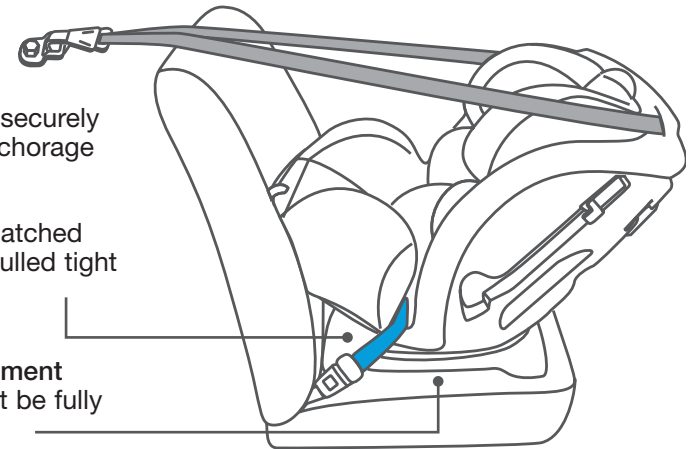

Recline Angle

Correct Recline Angle

When used forward facing the restraint must always be correctly reclined. The white arrow on the shell must be above one of the yellow arrows on the base.

Select a position that gives the most comfort for your child.

IMPORTANT A correct recline angle is essential for your child's safety.

DO NOT use the position marked by the blue arrow when the restraint is forward facing.

To Adjust:

1. Pull the release handle on the shell fully forward.

2. Rotate the shell until the white arrow is above one of the yellow arrows.

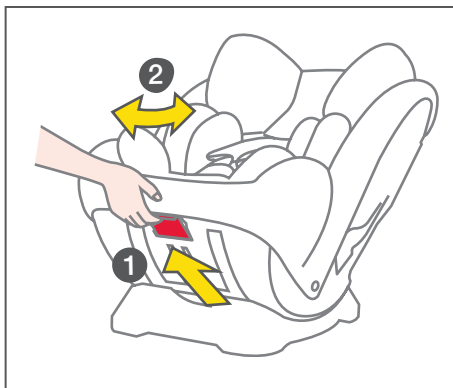
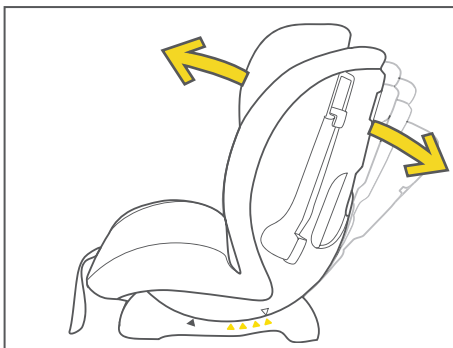

Installation

See page 7 for recommended positions in the vehicle.

Place the restraint on the vehicle seat forward facing.

1. Pull the vehicle lap/sash belt out and thread it through the vehicle belt slots at the back of the child restraint.
2. Engage the vehicle belt buckle.

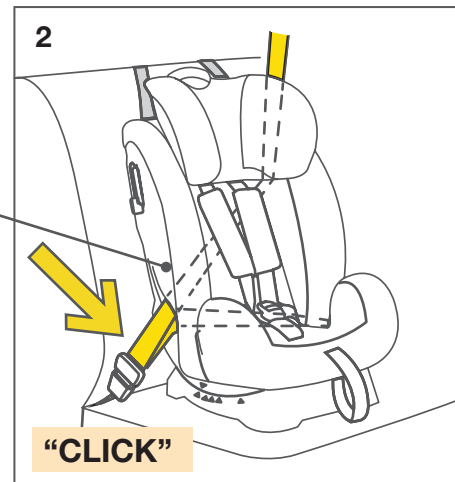
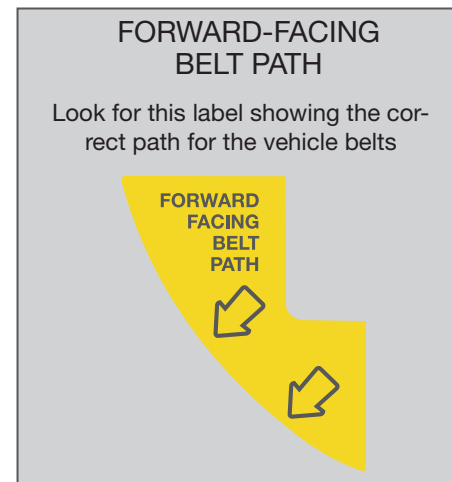

Installation

FORWARD-FACING BELT PATH

Look for this marking showing the correct path for the vehicle sash belts



3. While pressing the child restraint down firmly into the vehicle seat, pull the vehicle sash belt until both lap and sash belts are tight.

4. Secure the sash belt in the belt lock off.

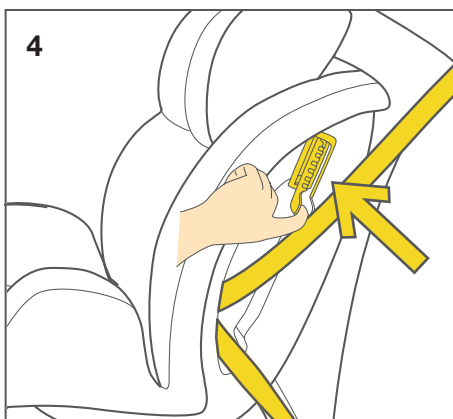
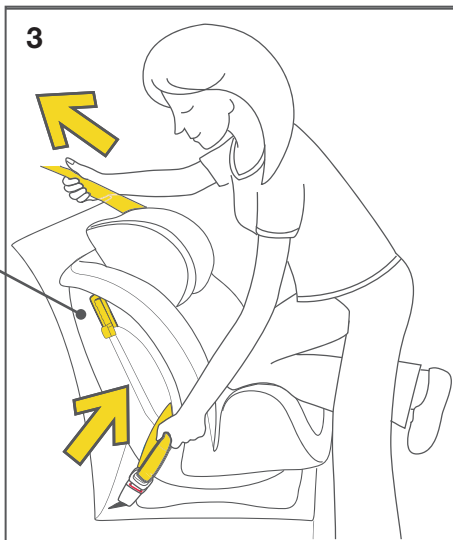

Installation

5. Pull the vehicle belts tight.

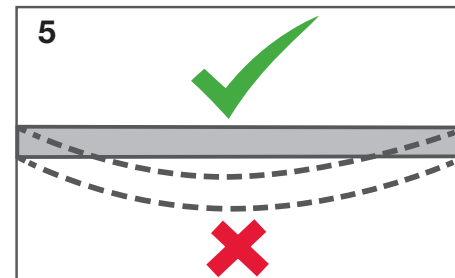

6. Ensure there are no twists in the belts.

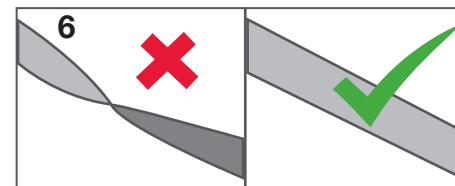

7. Connect the top tether strap.

NOTE: many vehicles have built-in top tether connection points. If your vehicle does not have these refer to page 26 for information on fitting the anchorage supplied.

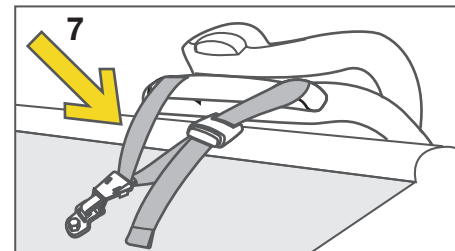

8. Store end of web in bag on back of cover.

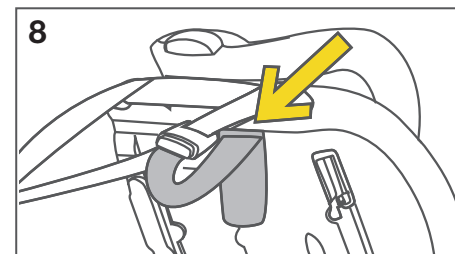

Installation

Tether Strap General Information

Also refer to page 23 for more Top Tether information.

Always connect the snap hook securely to the anchorage fitting.

No twists in web.

Web pulled tight.

Increase tether tension by pulling web out. If the web is stiff to pull through the adjuster also press the release button.

Reduce tension by pressing release button and pulling web out.

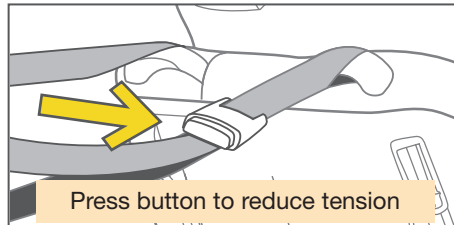
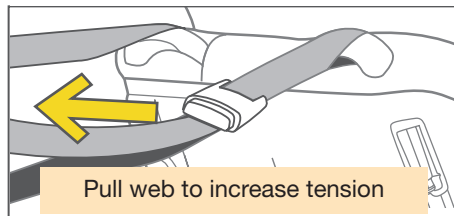
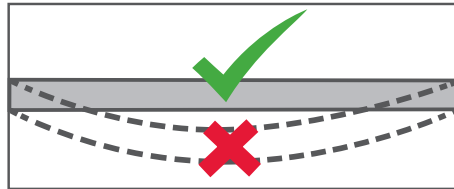
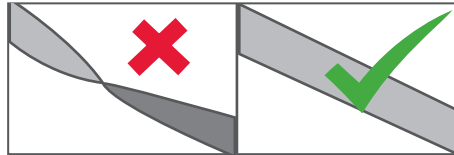
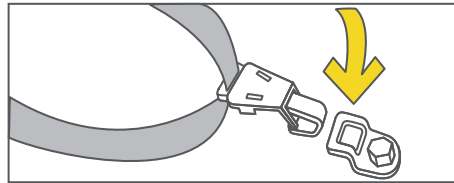

Checklist

Tether Strap - securely attached to anchorage and pulled tight.

Ensure there are no twists in the webbing.
End of tether in storage bag

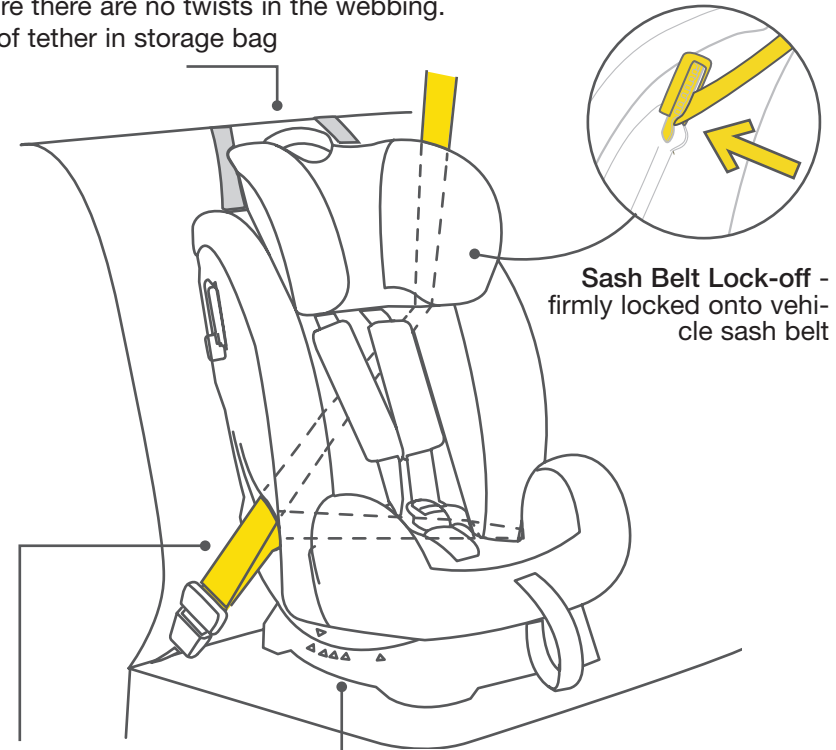

Sash Belt Lock-off - firmly locked onto vehicle sash belt

Vehicle Belts - must always be secure and pulled tight.

Base Recline adjustment - restraint must be reclined only use positions 2-5

⚠ WARNINGS

TOP TETHER

THIS RESTRAINT MUST BE ATTACHED TO A CHILD RESTRAINT UPPER ANCHORAGE POINT IN THE CAR.

REFER TO CAR OWNERS HANDBOOK FOR LOCATION OF UPPER ANCHORAGE POINTS.

REFER TO A CHILD RESTRAINT FITTING STATION IF NO ANCHORAGE POINTS ARE IN THE MOTOR CAR.

THIS RESTRAINT IS NOT SUITABLE FOR USE WHERE THE TOP TETHER STRAP MAY FALL INTO A SPLIT IN THE SEAT BACK OR OFF THE SIDE OF THE SEAT.

Always secure the loose end of the top tether strap to prevent it hanging out of the car or being accessible by the child. Store it in the bag attached to the back of the cover.

Do not use the child restraint where this strap may fall into a split in the seat back or off the side of the seat.

ALWAYS ATTACH HOOK AND REMOVE SLACK.

CAUTION: CHILDREN CAN BE INJURED OR RESTRAINTS AND TOP TETHER STRAP DAMAGED BY UNSECURED CARGO IN A COLLISION. SECURE OR REMOVE HAZARDOUS CARGO BEFORE USING THIS CHILD RESTRAINT.

Top Tether - Features

This child restraint has a tether strap permanently attached to the back of the seat. **Always use this tether strap.**

Connect the tether strap to the built-in anchorage fitting in the vehicle, or if there is not one available, install the anchor fitting supplied with this restraint by following the instructions at the end of this section.

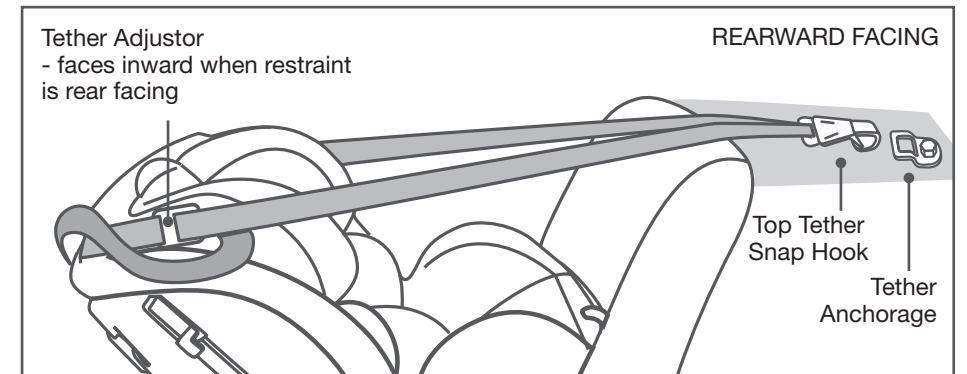
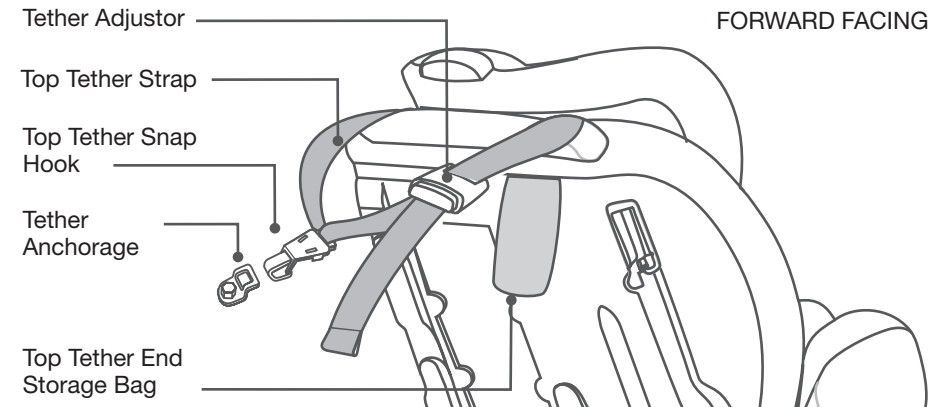

Tether Anchorage Installation

Most cars have several threaded holes to fit the tether anchorage to. Refer to the vehicle owners handbook for information on the location of these points.

Using the bolt provided attach the anchor fitting to the mounting point behind where the child restraint is to be installed.

See more detailed information on the next page.

The anchor fitting must be aligned as shown unless stated otherwise in the vehicle owners handbook.

If drilling a new hole, select a position on the centre line of the seating position, and no closer than 100 mm from the front edge of the parcel shelf.

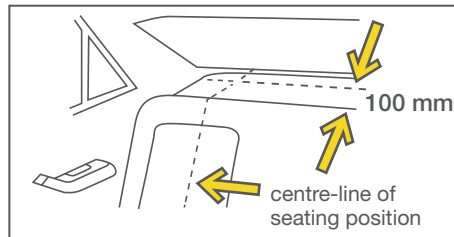
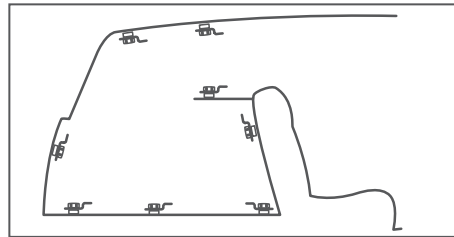
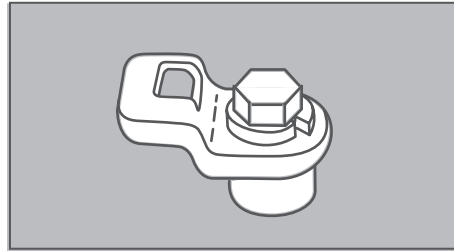
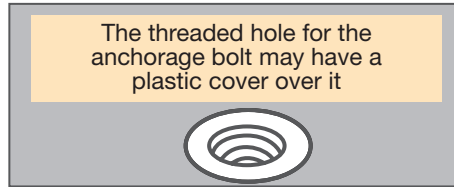

Tether Anchorage Installation

If the car is fitted with a child restraint anchorage point:

Locate the upper anchorage point behind the rear seating position (consult the vehicle owners handbook for location of the upper anchorage point). Remove the thread plug from the parcel shelf/floor/roof and install the attachment bolt as shown opposite.

CAUTION:
DO NOT OVERTIGHTEN THE ATTACHMENT BOLT. MAXIMUM TORQUE 20Nm.

In some vehicles without a fixed parcel shelf an extension tether strap may be required. These are available in several different lengths and can be obtained from child restraint retail outlets.

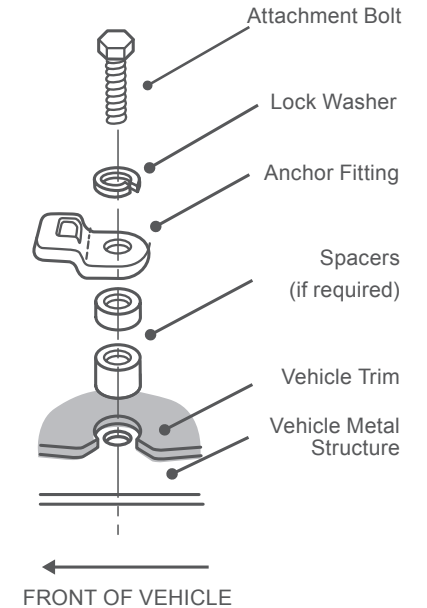

Tether Anchorage Installation

If the car is not fitted with a child restraint upper anchorage point:

For sedans only - drill a 9 mm hole in the parcel shelf on the centre line of the seating position as shown on page 22.

Install the anchor bolt as shown opposite.

It is recommended that this installation be carried out by a child restraint fitting station or licenced motor mechanic.

For vehicles other than sedans:

In Australia, consult your nearest child restraint fitting station or traffic authority for vehicle inspection to find the best, correct position for the placement of the upper anchorage point, and for the correct attachment bolt length and use of spacers.

In New Zealand, consult the agent for the vehicle.

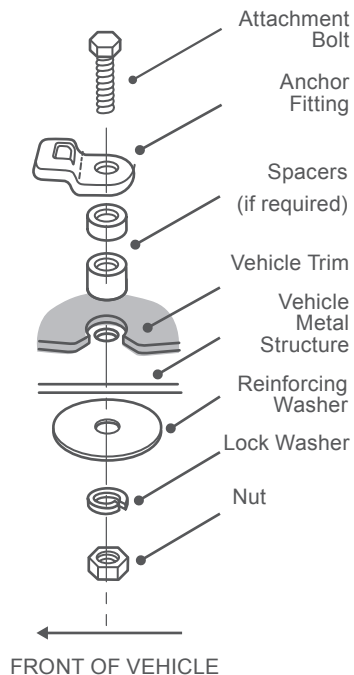

WARNING

CHILD RESTRAINTS MUST NOT BE ATTACHED TO UNSOUND METAL OR WOOD OR SYNTHETIC STRUCTURES. WHEN DRILLING THE 9 MM HOLE DO NOT DRILL THROUGH FUEL LINES, FUEL TANKS, ELECTRICAL WIRING, OR RADIO SPEAKERS. WEBBING STRAPS MUST BE PROTECTED FROM SHARP CORNERS AND EDGES.

THE ANCHOR FITTING MUST BE USED ONLY AS DESCRIBED ABOVE. IT MUST NOT BE HOOKED ONTO ANY OTHER OBJECT.

Securing a Child in the Restraint - Recline Angle

This restraint should be installed in the rear seat. See Installation instructions.

Correct Recline Angle

When used rear facing the restraint must always be fully reclined. The white arrow on the shell must be above the blue arrow on the base.

IMPORTANT: A correct recline angle is essential for your baby's safety.

To Adjust:

1. Pull the release handle on the shell fully forward.

2. Rotate the shell until the white arrow is above the blue arrow.

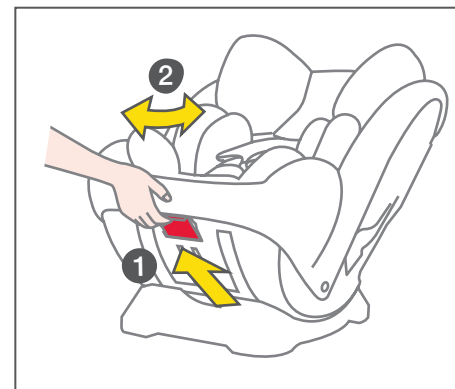
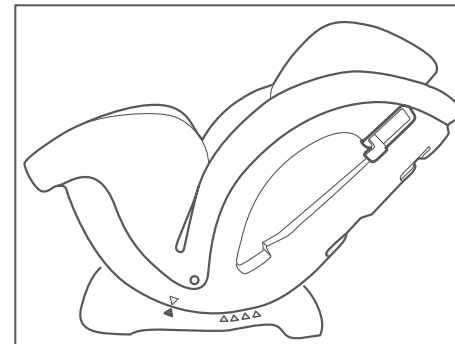

Securing a Child in the Restraint - Shoulder Strap height labels

This restraint has shoulder height level labels.

Use these labels to decide if the restraint should be rear or forward facing.

If your child's shoulders are below the bottom dotted line **A** the restraint must be rearfacing.

Once your child's shoulders pass the line **A** they can be either rear-facing or forward facing.

Once your child's shoulders reach the dotted line **B** the restraint must be forward facing.

See page 36 for information about forward facing use.



B

SHOULDERS BELOW THIS LINE WHEN
HEADREST AT HIGHEST POSITION

A

MUST BE FORWARD FACING WHEN
SHOULDERS ABOVE THIS LINE

MUST BE REAR FACING WHEN
SHOULDERS BELOW THIS LINE

IMPORTANT: Children are safer rear facing. Joie recommends that they remain rear facing until their shoulders reach line B

Securing a Child in the Restraint - Shoulder Strap height

Correct positioning of the shoulder straps is essential for your baby's safety.

Requirement:

The shoulder straps must be positioned near to the child's shoulders, but not lower than the child's shoulders.

The straps should be in the next available adjustment position above your child's shoulders.

Note: the shoulder strap height requirement rear facing is different to forward facing.

To Check:

With baby placed in the restraint, note where the shoulder straps are positioned relative to the shoulders.

To Adjust:

If adjustment is needed squeeze the headrest adjuster handle and raise or lower the headrest and shoulder straps as required.

IMPORTANT: Always adjust the height of the shoulder straps as the child grows

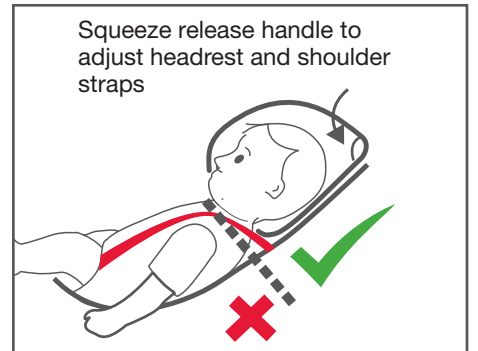

Securing a Child in the Restraint - Using the Harness

FIRST CHECK SHOULDER STRAP HEIGHT AND ADJUST IF NECESSARY. See previous page.

1. Loosen harness by pressing on adjuster button A while pulling on the harness straps B.

2. Press button to open the quick release buckle. Spread harness straps apart.

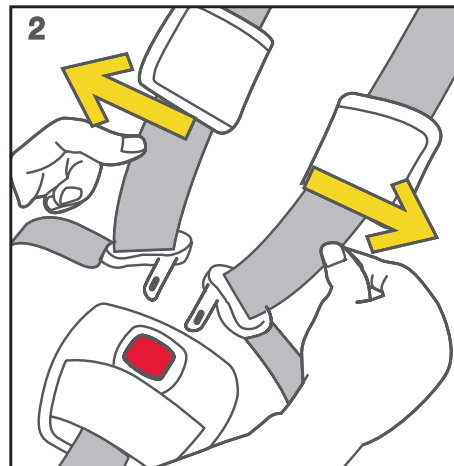

IMPORTANT

Infants need to be securely held by the harness. An infant wrapped in a blanket or swaddled will not be securely held and may be ejected and killed in an accident.

The harness needs to fit the infant securely.

Only place any blanket or other covering over the harness after it is adjusted.

Do not bind or wrap the infants arms or legs together.

Securing a Child in the Restraint - Using the Harness

3. Place child in restraint in seated position.

IMPORTANT:
Child must be dressed in clothing that allows the harness to firmly secure them.

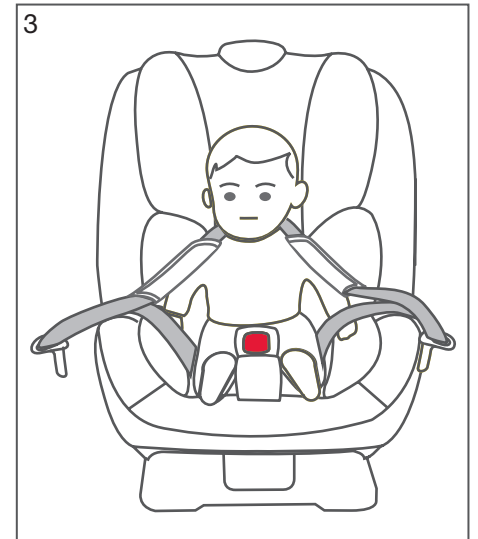

4. Child must be placed firmly against both the back and bottom of the seating surface.

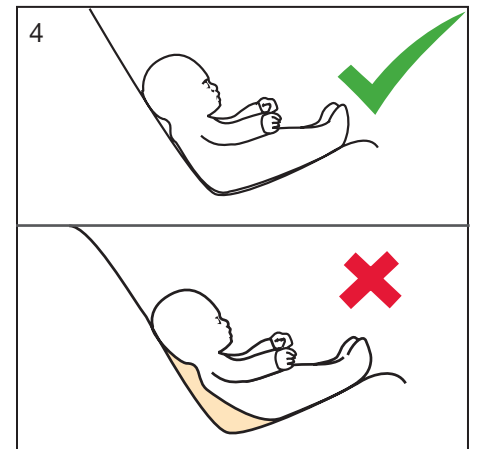

Securing a Child in the Restraint - Using the Harness

5. Place buckle tongues into the quick release buckle.

IMPORTANT
The buckle tongue pushed in last should “CLICK” when it locks into place. If it does not click, try again or try cleaning the buckle.

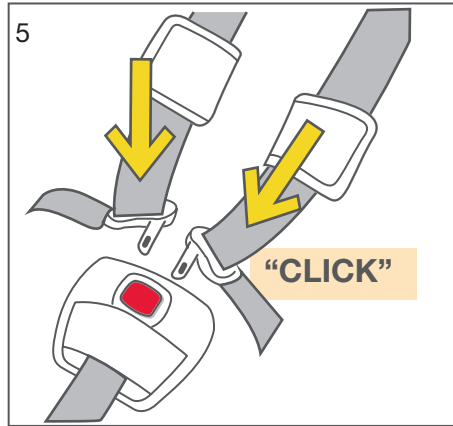

6. Make sure there are no twists in the straps.

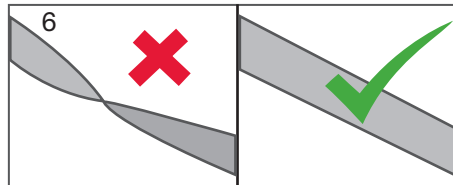

7. Recheck shoulder strap height.

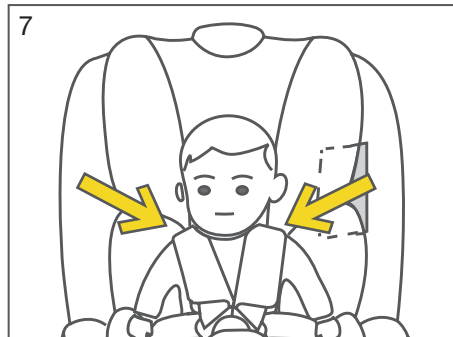

WARNING
DO NOT LEAVE CHILDREN UNATTENDED IN THE CAR

Securing a Child in the Restraint - Adjusting the Harness

8. Tighten harness by pulling on the adjuster strap at the front of the restraint.

Shoulder straps should be a snug fit.

Note: sometimes the straps may be loose in the lap part of the harness.

You may need to pull loose straps through the buckle tongues upward towards the child’s shoulder and then pull again on the adjuster strap.

This may need to be repeated several times to get a snug fit.

9. Correct strap tension.

Put a finger under each strap and pull gently outwards.

There should be no gap between your finger and the baby.

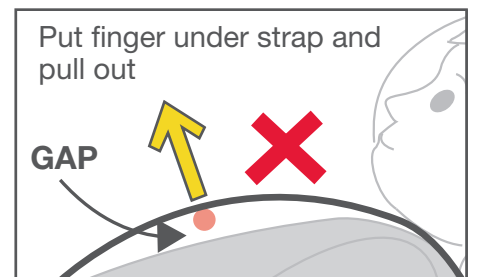
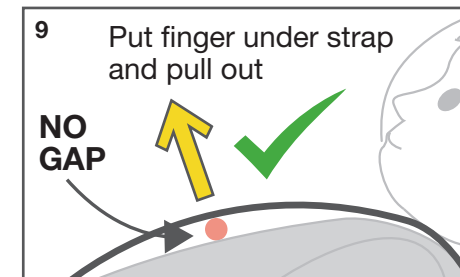
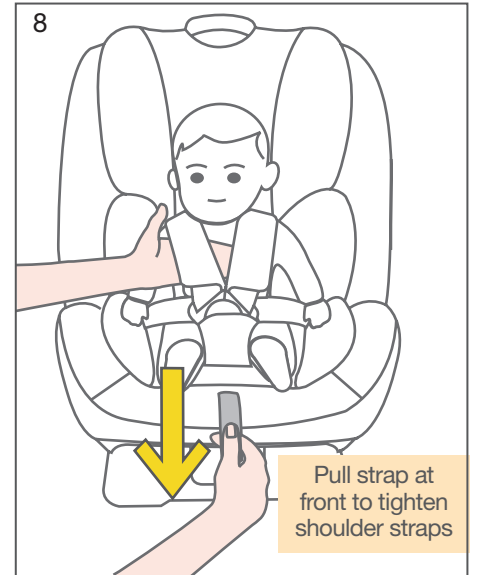

Checklist

Shoulder Straps - must always be at correct height and pulled tight.

Infant Insert - only use for smaller children who require more support.

Harness Straps - must not be twisted.

Shoulder Height - shoulders must not be above the middle marker line

Quick Release Buckle - must always be securely fastened.

Child position - child must be in full contact with back of restraint.

Recline angle - use full recline for rear facing.

Harness Tension - pull harness tight.

Suitable clothing - child's clothing must allow the harness to securely grip the child.

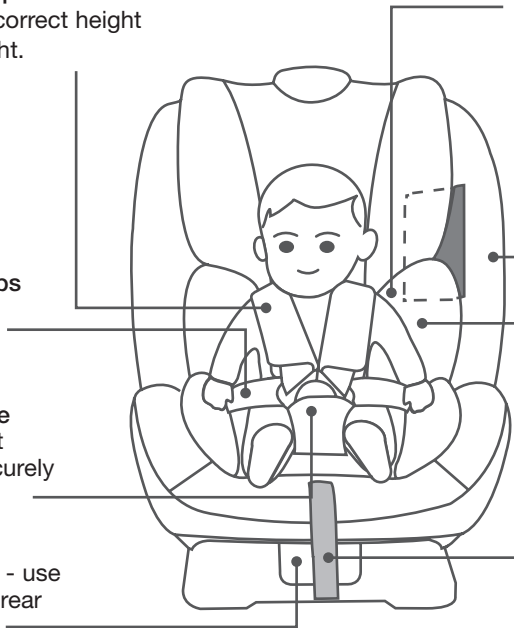

Securing a Child in the Restraint - Recline Angle

Correct Recline Angle

When used forward facing the restraint must always be correctly reclined. The white arrow on the shell must be above one of the yellow arrows on the base.

Select a position that gives the most comfort for your child.

IMPORTANT
A correct recline angle is essential for your child's safety.

DO NOT use position 1 marked by the blue arrow when the restraint is forward facing.

To Adjust:

1. Pull the release handle on the shell fully forward.

2. Rotate the shell until the white arrow is above one of the yellow arrows.

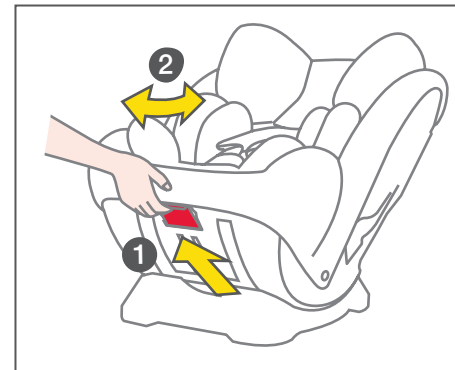
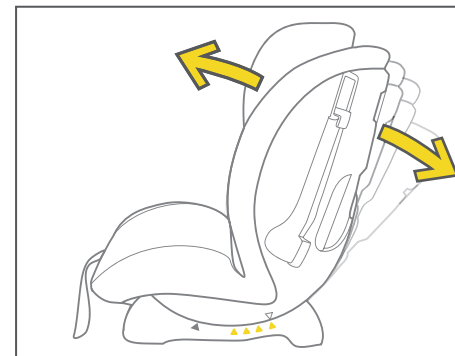

Securing a Child in the Restraint - Shoulder Strap height labels

This restraint has shoulder height level labels. Use these labels to decide if the restraint should be rear or forward facing. If your child's shoulders are below the bottom dotted line **A** the restraint must be rearfacing.

Once your child's shoulders pass the line **A** they can be either rearfacing or forward facing.

Once your child's shoulders reach the dotted line **B** the restraint must be forward facing. Once your child passes line **C** they are too big for this restraint and need to move to a Booster Seat.



C

SHOULDERS BELOW THIS LINE WHEN
HEADREST AT HIGHEST POSITION

B

MUST BE FORWARD FACING WHEN
SHOULDERS ABOVE THIS LINE

A

MUST BE REAR FACING WHEN
SHOULDERS BELOW THIS LINE

IMPORTANT: Joie recommends that children remain rear facing until their shoulders reach line B.

Securing a Child in the Restraint - Shoulder Strap height

Correct positioning of the shoulder straps is essential for your child's safety.

Requirement:

The shoulder straps must be positioned near to the child's shoulders, but not more than 25 mm below the child's shoulders.

Note: the shoulder strap height requirement forward facing is different to rear facing.

To Check:

With child placed in the restraint, note where the shoulder straps are positioned relative to the shoulders.

To Adjust:

If adjustment is needed squeeze the headrest adjuster handle and raise or lower the headrest and shoulder straps as required.

IMPORTANT: Always adjust the height of the shoulder straps as the child grows

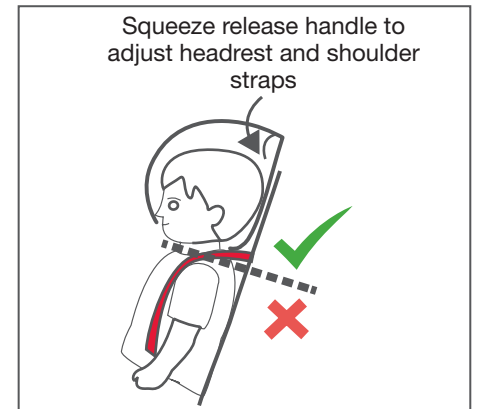

Securing a Child in the Restraint - Using the Harness

FIRST CHECK SHOULDER STRAP HEIGHT AND ADJUST IF NECESSARY.

1 Loosen harness by pressing on adjuster button A while pulling on the harness straps B.



2 Press button to open the quick release buckle.

Spread harness straps apart.

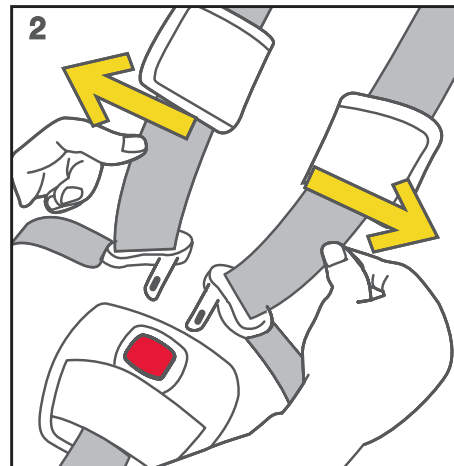

Securing a Child in the Restraint - Using the Harness

3 Place child in restraint in seated position firmly against both the back and bottom of the restraint.

IMPORTANT
Children need to be securely held by the harness. Children must be dressed in clothing that allows the harness to firmly grip them. Do not wrap the child in a blanket or similar. Only place such covering over the child after they are strapped in.

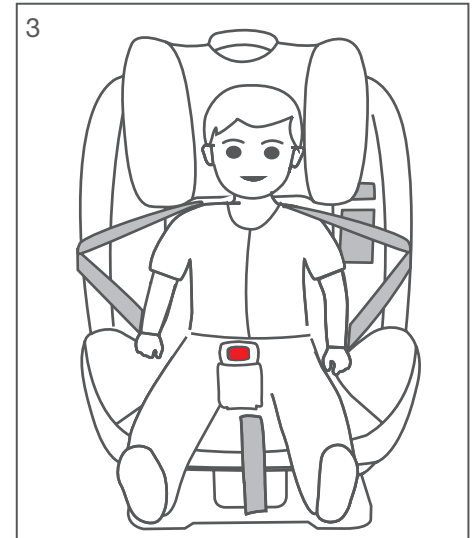

4 Place buckle tongues into the quick release buckle.

IMPORTANT:
The buckle tongue pushed in last should "CLICK" when it locks into place. If it does not click, try again or try cleaning the buckle.

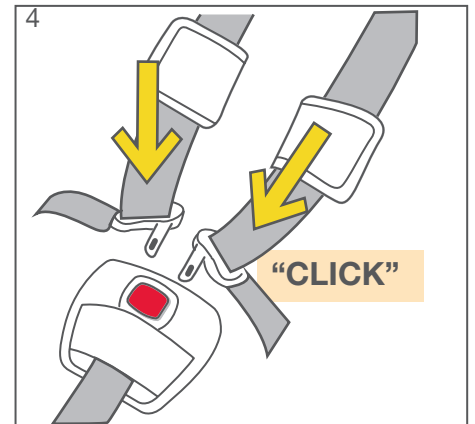

Securing a Child in the Restraint - Adjusting the Harness

5. Make sure there are no twists in the straps.

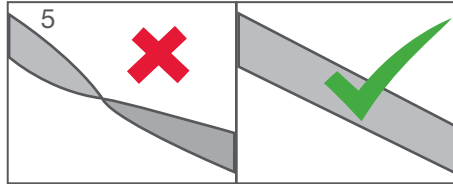

6. Recheck shoulder strap height. Tighten harness by pulling on the adjuster strap at the front of the restraint.

Note: the lower harness webbing may not pull freely through the harness buckle tongues.

You may need to pull the webbing through the buckle tongues up towards the child's shoulder then pull on the adjuster strap again.

This may need to be repeated several times to get the webbing fitting snugly.



WARNING

DO NOT LEAVE CHILDREN UNATTENDED IN THE CAR

Securing a Child in the Restraint - Adjusting the Harness

7. Correct strap tension. Put a finger under each strap and pull gently outwards. There should be no gap between your finger and the child.

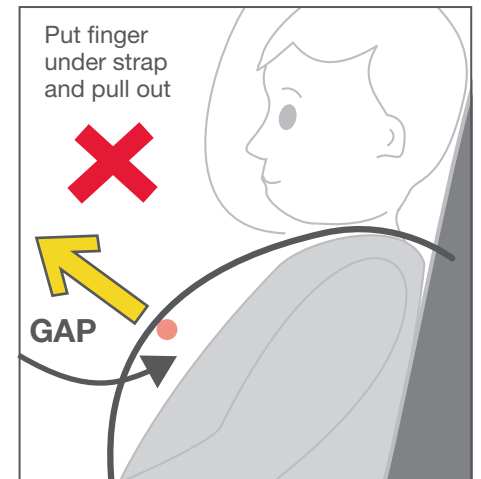
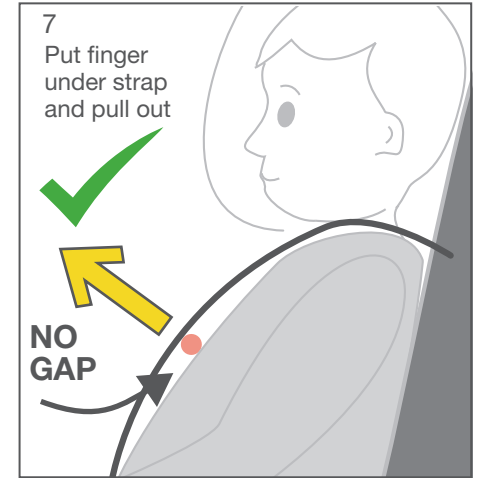

Checklist

Shoulder Straps - must always be at correct height and pulled tight.

Infant Insert - only use for smaller children who require more support.

Harness Straps - must not be twisted.

Shoulder Height - shoulders must not be above the upper marker line

Quick Release Buckle - must always be securely fastened.

Child position - child must be in full contact with back of restraint.

Recline angle - use positions 2-5. Do not use position 1.

Harness Tension - pull harness tight.

Suitable clothing - child's clothing must allow the harness to securely grip the child.

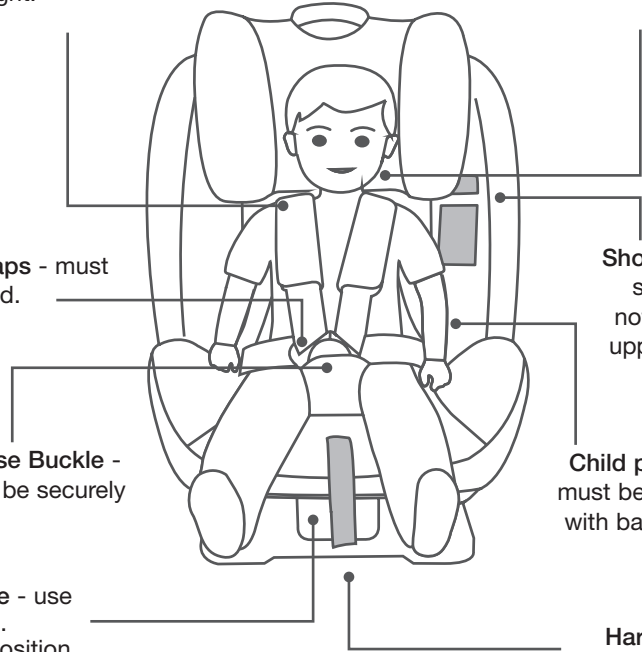

Liner

Rear Facing

This restraint has a soft padded liner for use with a baby or small child. Use this liner for more comfort or if they are not fully supported by the main cover.



Forward Facing

The liner should be used for small children only.

It should be removed when they grow older than about 6 months.

DO NOT use the liner if the child is so big that it is preventing them having some movement.

Shoulder, Lap and Crotch pads.

These are for comfort only and can be removed at any time.

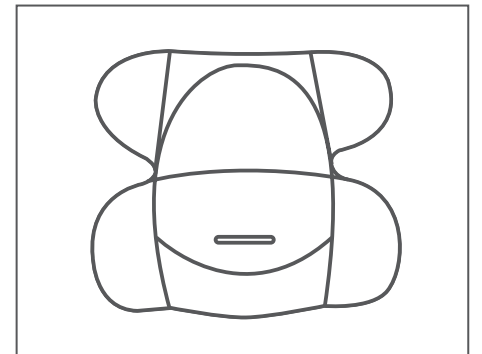

VERY IMPORTANT: Only replace the cover with a Joie supplied replacement cover with identical shoulder height markers or a replacement cover meeting AS/NZS 8005.

Cover Removal

To Remove

1. Press the red button down to disengage the QR buckle and remove webbing and spread outwards,
2. Remove the Infant Insert, Shoulder Pads and Crotch Pad if fitted,

Headrest cover

3. Detach elastic loop fasteners at back of headrest and remove the head support cover by pulling forward over the headrest.

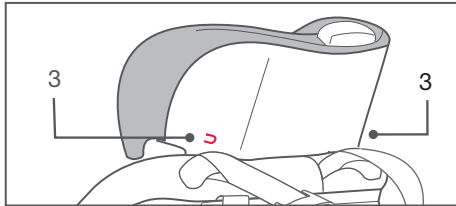

Seat Cover

4. Detach the press studs on sides of seat pad and back of seat pad.
5. Detach the press studs inside the cover.
6. Pull the QR buckle through the slot in the seat pad and then remove seat pad from seat shell.

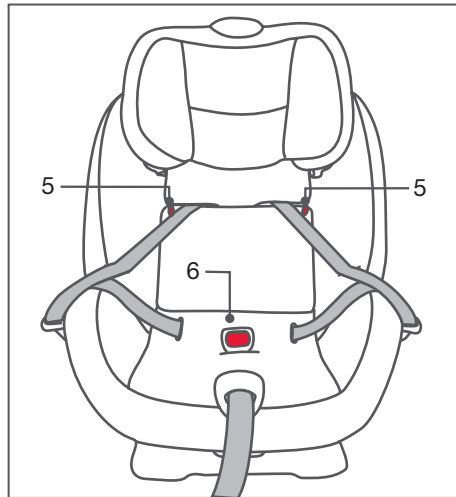

Refit Cover

To Refit

Seat Cover

1. Place the main cover into the seat.
2. Thread the QR buckle through the slot in the cover, and move the harness lap straps into the slots in the cover.
3. Secure the press studs inside and outside the shell.
4. Replace the infant Insert, Shoulder Pads and Crotch pad if using these items.

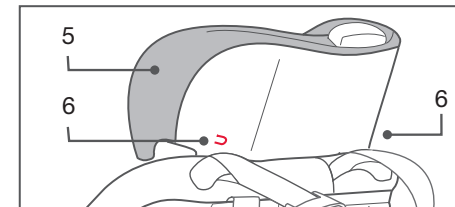

Headrest Cover

5. Pull the headrest cover over the headrest from the front.
6. Locate the elastic loops and thread these under the headrest and reattach to the lugs at the back of the headrest.

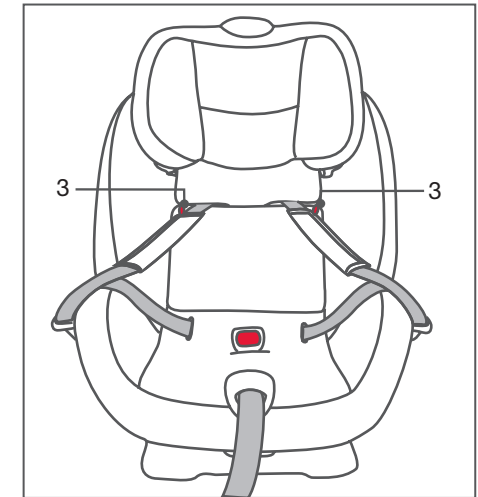

Cleaning and Maintenance

SEAT COVER

Wash with cold water at less than 30 degrees C.

Do not iron.

Do not bleach or dry clean.

Do not twist the soft goods to dry with great force. It may leave the seat cover with wrinkles.

Hang dry the seat cover. Do not tumble dry.

PLASTIC AND METAL PARTS

Use only mild detergent, water and a soft cloth to clean the car seat shell, handle and harness straps. Air dry.

Do not use undiluted detergent, or other solvents to clean - these may cause damage.

HARNESS STRAPS

Shoulder harness straps are not removable.

Clean with mild detergent, water and a soft cloth only.

HARNESS BUCKLE

To clean the buckle: rinse using warm water. DO NOT use any soaps, solvents or lubricants. Using anything other than water can cause the buckle to malfunction. Air dry.

When the buckle is operating correctly the tongues will push in easily and the second tongue will CLICK when it latches into place.

If the buckle does not appear to be working correctly get it checked or replaced by contacting the retailer from where it was purchased, or by contacting Australia's Power Brands.

STORAGE

Remove the child restraint from the vehicle seat if not in use for a long period of time. Put the child restraint in a cool, dry place where your child cannot access it.

The Next Restraint

Booster seats are available for children up to approximately 8 or 10 years of age.

IMPORTANT: Children are at risk of serious injury if they move to booster seats too early.

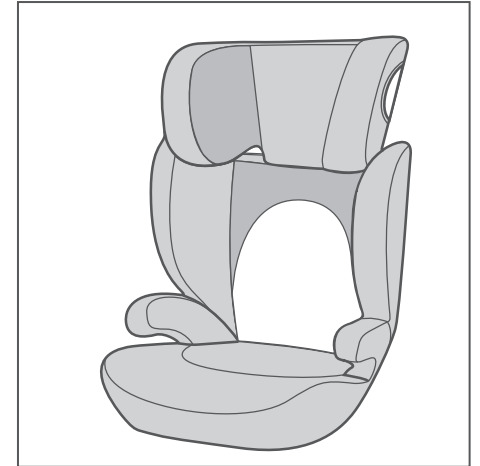



Distributed by Allison AU Pty Ltd

ACN: 642 240 140

Unit 1, 35 Lyn Parade

Prestons

NSW Australia 2170

For after-sales & warranty service, contact:

1800 951 070

customerservice@allisonau.com.au

IM-001943C