

Joie™

Instruction Manual

chai™

multi-mode highchair

Weight: Birth up to 60 lb. (27.2 kg)

Age: Birth up to 6 years

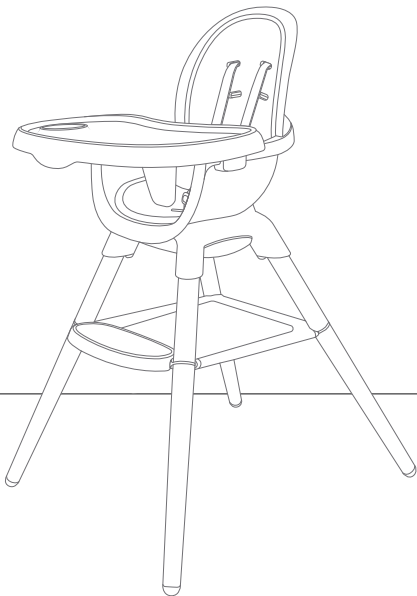

product
guide videos



IMPORTANT!

Read the instructions in this manual before use of the product.
Keep this manual for future use.

Contents:

- 3 Warranty Information
- 4 Warnings
- 8 Choose Your Usage Mode
- 10 Parts List
- 12 Assembling Highchair
- 18 Leg Assembly Options
- 20 Using Restraint Buckle
- 22 Adjusting Waist & Shoulder Harness Straps
- 24 Adjusting Recline
- 26 Using Tray
- 28 Using Infant Booster
- 32 Using Toddler Booster
- 38 Storing Booster Straps
- 40 Using Youth Chair
- 46 Using Youth Stool
- 48 Removing Seat Pad & Back Pad
- 48 Removing Basket
- 50 Care & Maintenance

Child Usage Requirements

This highchair is suitable for use with children who meet the following requirements:

Newborn Highchair	Birth - able to sit up unaided (approx. 6 months)
Highchair	Able to sit up unaided (approx. 6 months) - 3 years, up to 40 lb. (18 kg).
Infant Booster	Able to sit up unaided (approx. 6 months) - 3 years, up to 40 lb. (18 kg).
Toddler Booster	3-6 years, up to 60 lb. (27.2 kg).
Youth Chair	Able to get in and out unassisted - 6 years, up to 60 lb. (27.2 kg).
Youth Stool	Able to get in and out unassisted (approx. 3 years) - 6 years, up to 60 lb. (27.2 kg).

Important:

Product Registration

Please fill in the information below. The model number and the date of manufacture are located on a label on the highchair frame. Fill out the prepaid registration postcard attached to the product and mail it today. To register your product online, please visit: <https://joiebaby.com/us/register-gear>.

Model Name: _____

Model Number: _____

Date of Manufacture: _____

Date of Purchase: _____

register your
product online



Limited Warranty

We have purposely designed our high-quality products so that they can grow with both your child and your family. Because we stand by our product, our gear is covered by a custom limited warranty per product, starting from the day it was purchased. Please have the proof of purchase, model number and date of manufacture available when you contact us. For warranty information please visit: www.joiebaby.com.

Contact:

In the USA:

Joie Baby USA Consumer Service Contact Info.

Address: 70 Thousand Oaks Blvd., Morgantown, PA 19543

In Canada:

Joie B  b   Canada Consumer Service Contact Info.

Address: PO Box 96528 RPO Brunswick, Kirkland, Quebec H9H 5L4

Email: info.us@joiebaby.com

Phone: 1-866-798-7866

⚠️ WARNING

Failure to follow these warnings and instructions could result in serious injury or death.

- **FALL HAZARD:** Children have suffered **SEVERE** head injuries, including skull fractures, when falling from highchairs. Falls can happen suddenly if child is not restrained properly.
- **ALWAYS** use the restraints and adjust them to fit snugly.
- **The tray is NOT** designed to hold the child in the highchair.
- **Stay near and watch** child during use.
- **NEVER** leave child unattended.
- **Child MUST be secured** in the highchair at **ALL TIMES** by the restraint system, both in the reclined and upright positions.
- **Only use the highchair in the upright position** with children capable of sitting upright unassisted.

⚠️ WARNING

Failure to follow these warnings and instructions could result in serious injury or death.

- **Children have suffered head injuries**, including skull fractures, **after falling** with or from booster seats.
- **Check that the booster seat is securely attached** to the adult chair before each use.
- **ALWAYS** use the restraints until child is able to get in and out of the booster seat without help (approx. 3 years). Adjust the restraints to **fit snugly**.
- **Recommended adult chair seat dimensions** are a minimum of 17 in. (43 cm) width X 14 in. (36 cm) depth. Minimum height of the adult chair backrest is 9 in. (23 cm).

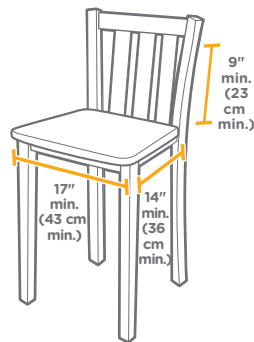

WARNING

Failure to follow these warnings and instructions could result in serious injury or death.





- **NEVER** allow child to **push away from the table**.
- **NEVER lift and carry** child in the booster seat.
- **Stay near and watch** your child during use.
- **To prevent serious injury or death, DO NOT** use in motor vehicles.
- **Use the booster seat ONLY** for children capable of sitting upright unassisted.
- **Until child is able to get in and out** of the booster seat without help (approx. 3 years), the child **MUST** be secured in the booster seat at **ALL TIMES** by the restraining system. The tray is **NOT** designed to hold the child in the chair.
- **ALWAYS** use the booster straps to securely attach the booster seat to an adult chair. Ensure that the straps are pulled tight.
- **DO NOT** use this product near stairs.
- **Adult assembly is required.**
- **DO NOT** use this product on stools, benches, or swivel chairs.

WARNING





Failure to follow these warnings and instructions could result in serious injury or death.

- **DO NOT** use the upright highchair until the child can sit up unaided.
- **DO NOT** allow child to stand in or on the product.
- **DO NOT** allow children to play with or around the highchair while occupied.
- **ALWAYS** use on a flat and level floor.
- **Be aware** of the risk of open fire and other sources of heat near the product.
- **To avoid strangulation hazard, DO NOT** place the product in any location where there are cords, such as window blinds, drapes, phone cords, etc.
- **DO NOT** use the product unless all components are correctly fitted and adjusted.
- **Regularly check** that all pieces are attached and secured properly before use.

Choose Your Usage Mode

Requirements	Usage Mode Types	
<p>Newborn Highchair (fully reclined ONLY)</p> <p>Birth - able to sit up unaided (approx. 6 months)</p>	<p>Table Height</p> 	<p>Counter Height</p> 
<p>Highchair</p> <p>Able to sit up unaided (approx. 6 months) - 3 years, up to 40 lb. (18 kg)</p>	<p>Table Height</p> 	<p>Counter Height</p> 
<p>Infant Booster</p> <p>Able to sit up unaided (approx. 6 months) - 3 years, up to 40 lb. (18 kg)</p>		

Choose Your Usage Mode

Requirements	Usage Mode Types	
<p>Toddler Booster</p> <p>3-6 years, up to 60 lb. (27.2 kg)</p>		
<p>Youth Chair</p> <p>Able to get in and out unassisted - 6 years, up to 60 lb. (27.2 kg)</p>		
<p>Youth Stool</p> <p>Able to get in and out unassisted (approx. 3 years) - 6 years, up to 60 lb. (27.2 kg)</p>	<p>Table Height</p> 	<p>Counter Height</p> 

Parts List:

Please make sure there are no missing parts. Please contact Joie Consumer Service if anything is missing.

- 1 Seat
- 2 Waist Harness Straps
- 3 Restraint Buckle
- 4 Crotch Strap
- 5 Basket
- 6 Footrest
- 7 Tray Insert
- 8 Tray
- 9 Youth Chair Feet
-  *Keep in storage boxes (16) when not in use.*
- 10 Upper Legs
- 11 Middle Legs
- 12 Lower Legs
- 13 Backrest Front Hooks
- 14 Backrest
- 15 Storage Box Release Buttons
- 16 Storage Boxes
- 17 Booster Straps
- 18 Back Pad
- 19 Shoulder Harness Straps
- 20 Tray Latch
- 21 Seat Pad
- 22 Backrest Release Tabs
- 23 Recline Adjustment Lever

Parts List:

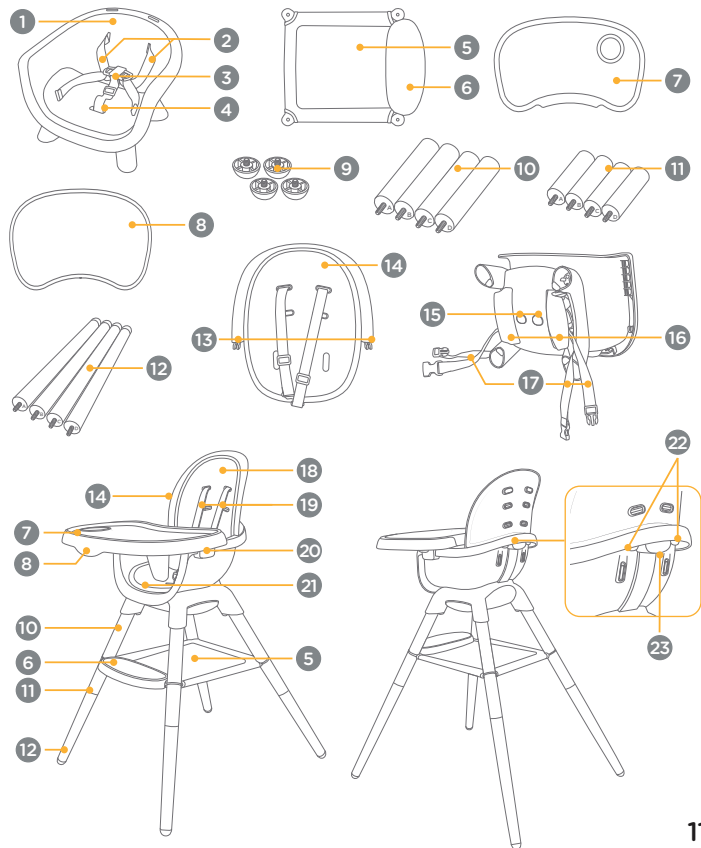

Assembling Highchair:

IMPORTANT: Each set of upper, middle, and lower legs are marked "A," "B," "C," or "D" on the top of the leg. Match the letters on each leg when assembling for the best fit.

See **pgs. 18-19** for leg assembly options before beginning assembly.

NOTE: The middle legs may come out of the box already attached to the lower legs.

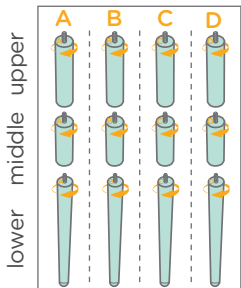

- 1 - Flip the seat upside down.
- 2 - Install all four upper legs onto the seat.
- 3 - Rotate the upper legs clockwise until they stop rotating. The upper legs cannot be installed if the storage boxes are open.
- 4 - Align the four corners of the basket/footrest with the openings on the upper legs.

IMPORTANT: Ensure that the footrest is facing the front of the seat.

- 5 - Install all four middle legs onto the basket/footrest.

(Assembling Highchair continued on pg. 14)

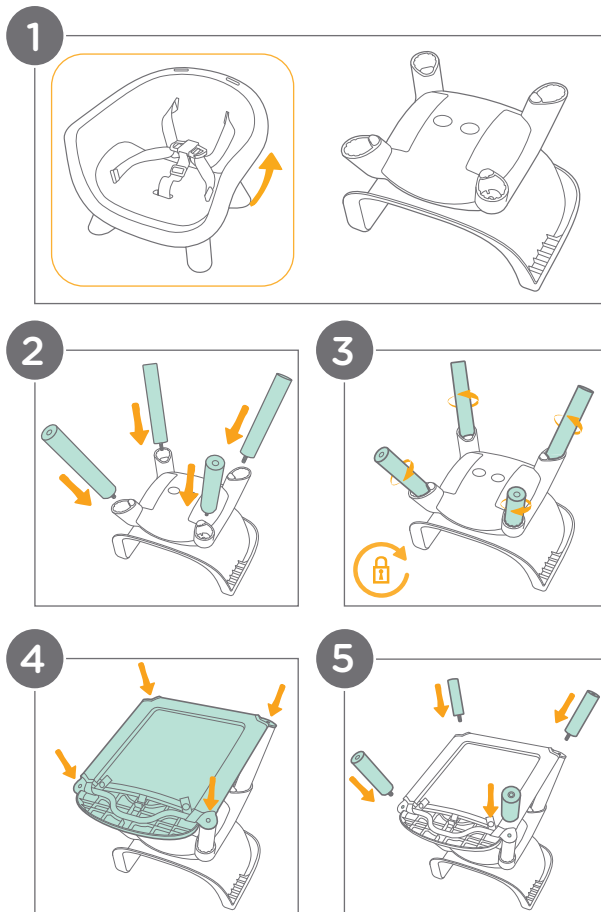

Assembling Highchair: (cont.)

6 - Rotate the middle legs clockwise until they stop rotating.

7 - Install all four lower legs onto the middle legs.

8 - Rotate the lower legs clockwise until they stop rotating.

9 - Flip the seat right-side up.

10 - Press the center button to release the restraint buckle.

11 - Insert the backrest front hooks into the side slots in the seat (A) and rotate the backrest release tabs into the rear slots (B).

(Assembling Highchair continued on pg. 16)

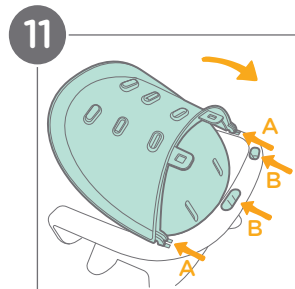
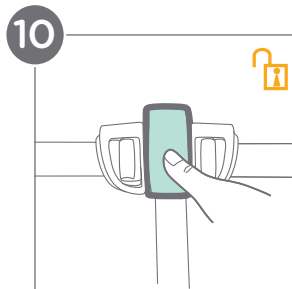
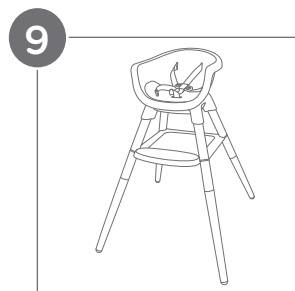
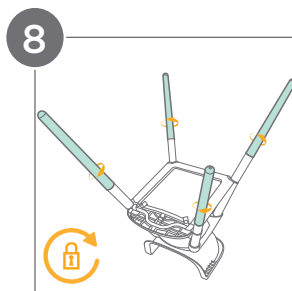
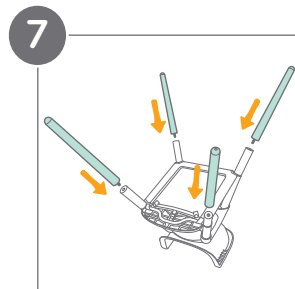
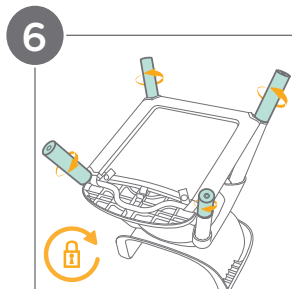

Assembling Highchair: (cont.)

- 12 - A “clicking” sound will confirm that the backrest is properly locked in place.
- 13 - Insert the tabs of the back pad into the top slots on the backrest.
- 14 - Thread the crotch buckle through the seat pad and then insert the seat pad into the seat.
- 15 - Thread the waist and shoulder harness straps through the corresponding openings on the back pad.

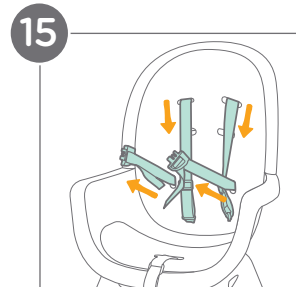
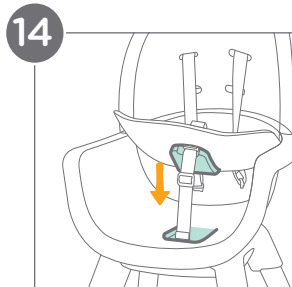
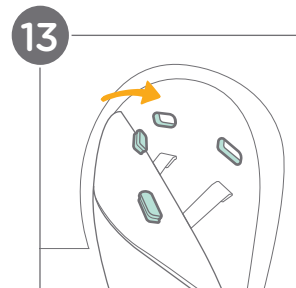

Leg Assembly Options:

1 - For **table height** highchair and youth stool modes, use the upper legs and the lower legs.

For **counter height** highchair and youth stool modes, use the upper legs, the middle legs, and the lower legs.

IMPORTANT: The basket/footrest **MUST** be installed for all highchair and youth stool modes, regardless of height. For basket/footrest installation help, see pg. 12.

Fully tighten all the legs. Ensure that there are no gaps between the legs to avoid instability.

2 - **Youth chair mode** only requires the upper legs and the youth chair feet.

1

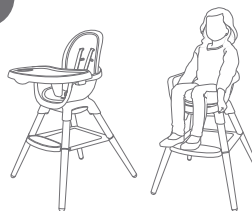
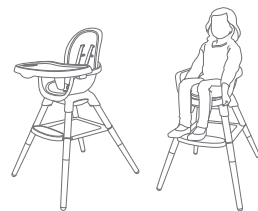
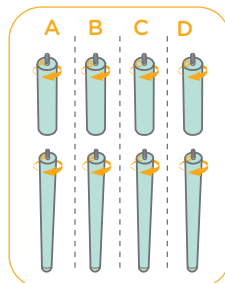
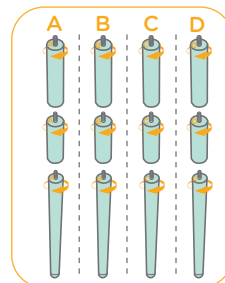

table height



counter height



2



youth
chair
mode

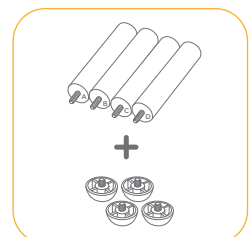

Using Restraint Buckle:

1 - Release the Restraint Buckle:

Locate the button in the center of the restraint buckle and press it firmly to release the harness straps.

2 - Lock the Restraint Buckle:

Slide the shoulder harness buckle into the waist belt buckle (A). Insert the combined buckles into the center restraint buckle (B). A “clicking” sound will confirm that the restraint buckle is properly locked in place (C).

IMPORTANT: To avoid serious injury from falling or sliding out, **ALWAYS** secure your child with the harness.

Make sure your child is snugly secured. The space between the child and the shoulder harness straps should be about a 1/2 inch (1 cm).

DO NOT cross the shoulder straps. This will cause pressure on the child’s neck.

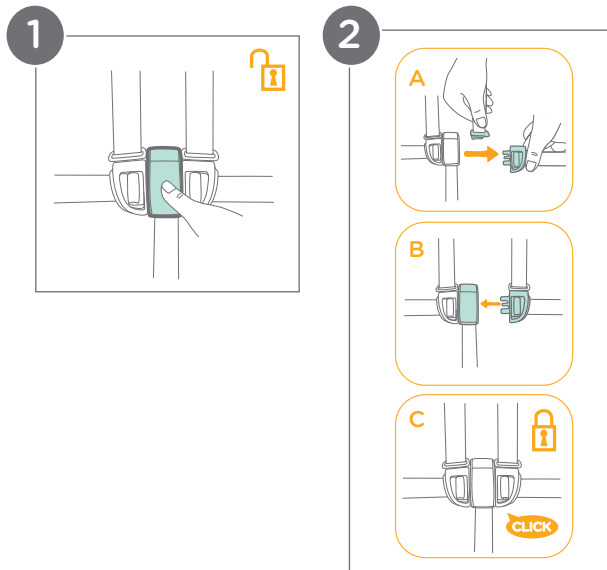

Adjusting Waist & Shoulder Harness Straps:

IMPORTANT: The shoulder harness must go into the slot that is even with or slightly above the child's shoulders.

In order to protect your child from falling out after they are placed into the seat, check whether the shoulder and waist harness straps are at the proper height and length.

- 1 - To adjust the position of the shoulder harness straps, turn the harness anchor to be in line with the harness strap. Thread it through the shoulder harness slot from back to front.
- 2 - Re-thread it through the correct slot from front to back.
- 3 - When changing the shoulder harness positions, make sure the shoulder harnesses are going through the same slots in both the backrest and the back pad.
- 4 - Use the slide adjuster (A) to adjust the length of the shoulder harness straps. Pull the waist harness strap (B) to tighten the waist harness. Press the button (C) on the waist belt buckle and pull to loosen the waist harness strap (B).

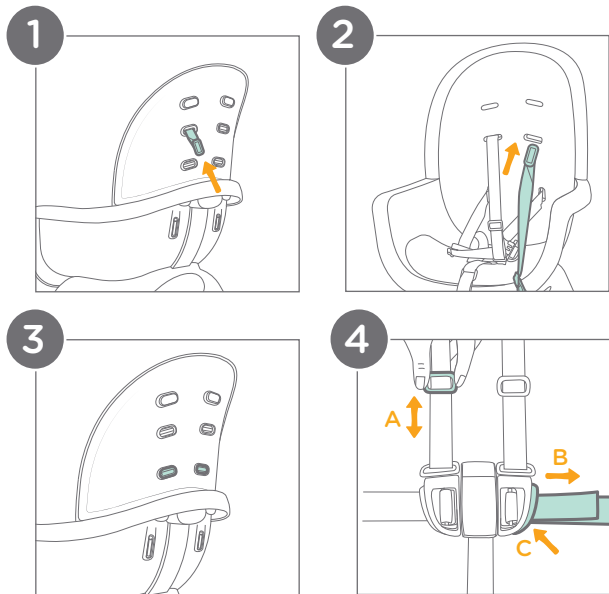

Adjusting Recline:

Recline can be adjusted to 4 positions.

- 1 - Squeeze the recline adjustment lever on the back of the seat and push down or pull up to adjust the backrest to the desired recline position.
- 2 - A “clicking” sound will confirm that the backrest is properly locked in place.
- 3 - The fully reclined position can be used from birth.

IMPORTANT: DO NOT adjust the recline with the child in the seat.

DO NOT use the tray while the seat is reclined.

Until the child can sit up unaided, **ONLY** use the highchair fully reclined.

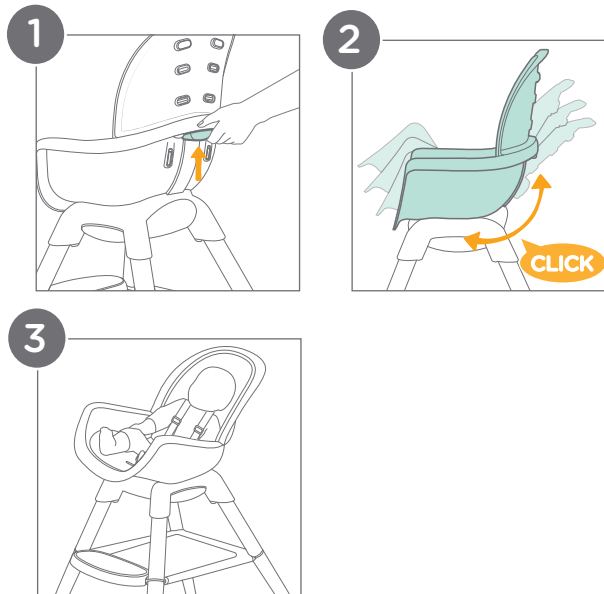

Using Tray:

- 1 - To attach the tray, pull the tray latches (A) outward and insert the tray onto both sides of the seat (B).
- 2 - Keeping the tray latches (C) pulled outward, move the tray (D) into one of the four possible positions, and then release the tray latches.
- 3 - If the tray is not automatically locked in place, move the tray until a “clicking” sound is heard.

IMPORTANT: Ensure that both sides of the tray are in matching positions. Pull the tray towards you after attachment to ensure that both sides are secure.

- 4 - To remove the tray, pull the tray latches (E) outward and pull up on the tray (F).
- 5 - To attach the tray insert, place it over the tray and push down until the tab snaps into place.
- 6 - To remove the tray insert, grasp the tab near the seating area and pull up. Then, lift the tray insert upward.

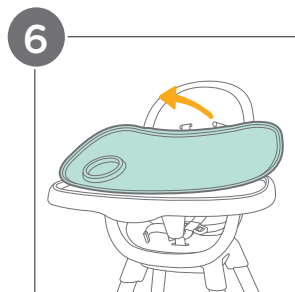
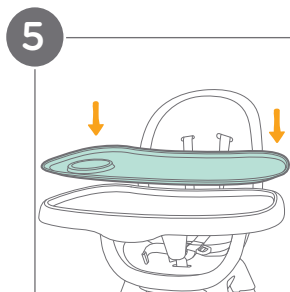
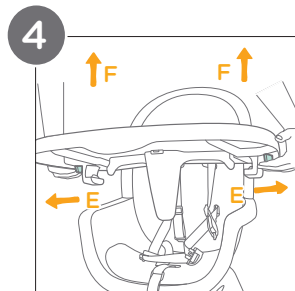
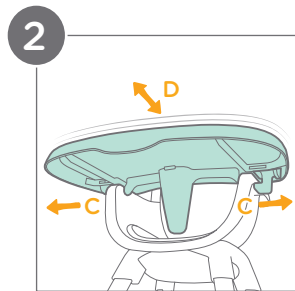
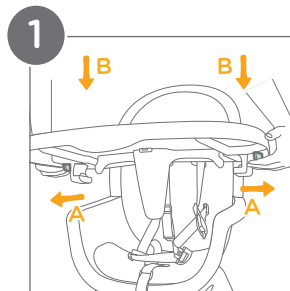

Using Infant Booster:

- 1 - Before using as an infant booster, it is necessary to remove the basket/footrest and **ALL** legs and store them away from children's reach.

IMPORTANT: Rotate the legs counterclockwise, from bottom to top, to remove them.

- 2 - Press the storage box release buttons under the seat to open the storage boxes. The storage boxes will not open if the upper legs are installed.
- 3 - Pull out the booster straps from both storage boxes.
- 4 - Place the seat on an adult chair. The infant booster cannot be reclined when using with an adult chair.

IMPORTANT: Recommended adult chair seat dimensions are a minimum of 17 in. (43 cm) width X 14 in. (36 cm) depth. Minimum height of the adult chair backrest is 9 in. (23 cm).

- 5 - Wrap the front set of the booster straps under the adult chair. Wrap the back set of the booster straps around the back of the adult chair. Ensure that the straps are not twisted.
- 6 - Buckle the safety buckle on the back of the adult chair.

(Using Infant Booster continued on pg. 30)

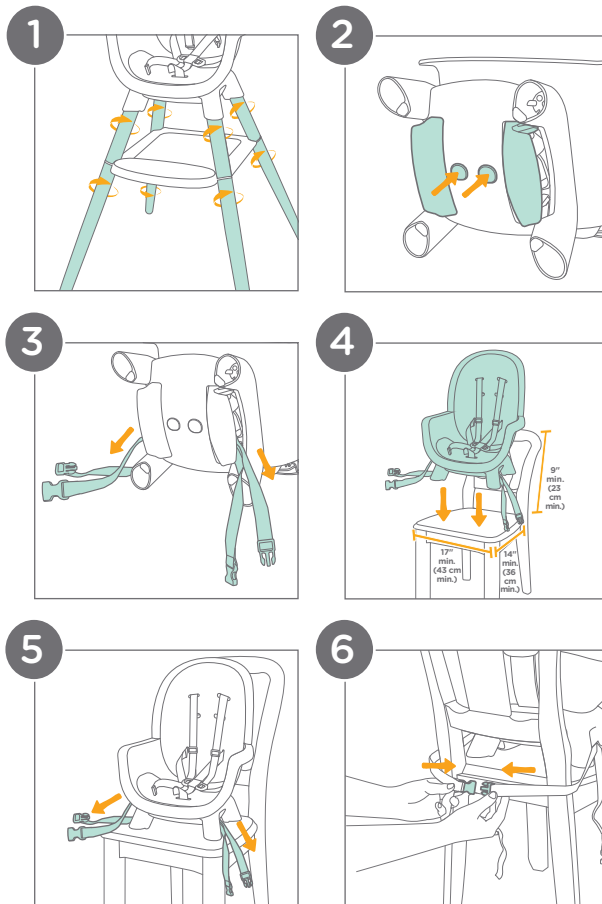

Using Infant Booster: (cont.)

- 7 - Tighten the strap on the adult chair by pulling on the tail end of the strap to ensure that the seat is snugly attached to the adult chair.
- 8 - Buckle the safety buckle on the underside of the adult chair.
- 9 - Tighten the strap on the adult chair by pulling on the tail end of the strap to ensure that the seat is snugly attached to the adult chair.
- 10 - Pull on the front and sides of the seat to ensure that the seat straps are snug and the infant booster seat does not move side-to-side or front-to-back.
- 11 - Buckle the safety buckle when child is in the seat. Adjust the straps according to the steps on pg. 22.

IMPORTANT: To avoid serious injury from falling or sliding out of the infant booster seat, **ALWAYS** secure your child with the harness.

Make sure your child is snugly secured. The space between the child and the shoulder harness straps should be about a 1/2 inch (1 cm).

DO NOT cross the shoulder straps. This will cause pressure on the child's neck.

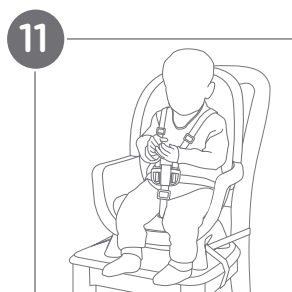
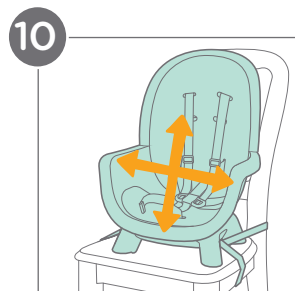
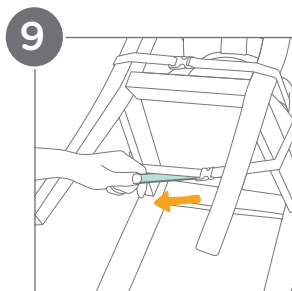
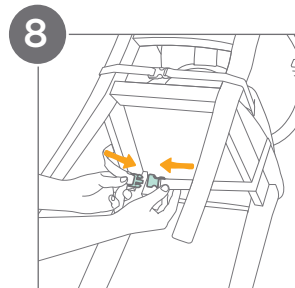
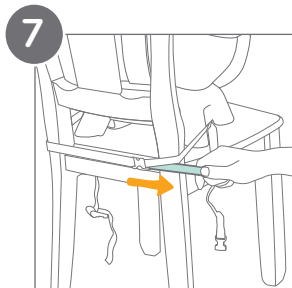

Using Toddler Booster:

- 1 - Before using as a toddler booster, it is necessary to remove the basket/footrest and **ALL** legs and store them away from children's reach.

IMPORTANT: Rotate legs counterclockwise, from bottom to top, to remove them.

Press the center button to release the restraint buckle and disconnect the shoulder and waist harness straps.

- 2 - Pull the backrest release tabs back and rotate the backrest forward to remove it, along with the shoulder straps.
- 3 - When removing the backrest, thread the waist harness straps out of the back pad and keep them attached to the seat.
- 4 - Press the storage box release buttons under the seat to open the storage boxes. The storage boxes will not open if the upper legs are installed.
- 5 - Pull out the booster straps from both storage boxes.

(Using Toddler Booster continued on pg. 34)

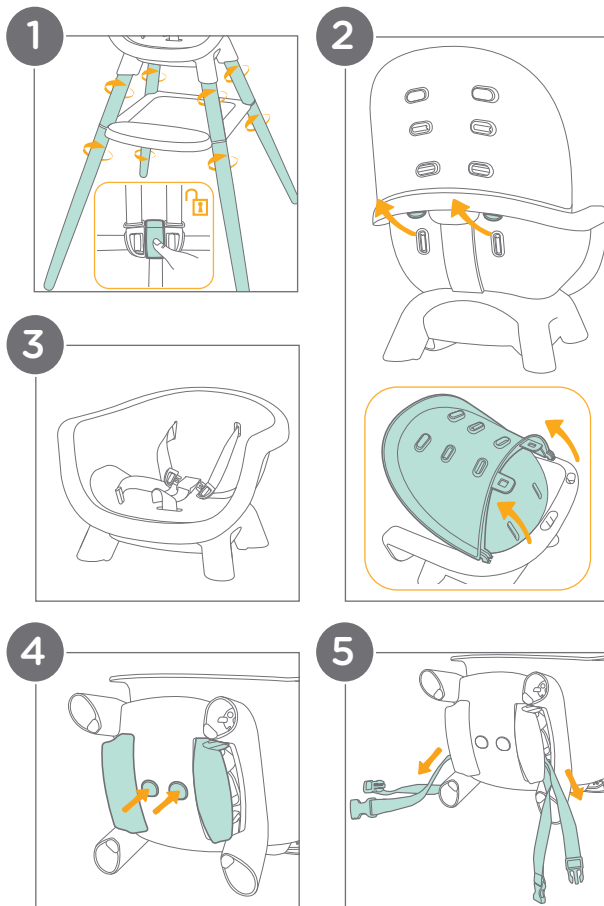

Using Toddler Booster: (cont.)

- 6 - Place the seat on an adult chair. The toddler booster cannot be reclined when using with an adult chair.

IMPORTANT: Recommended adult chair seat dimensions are a minimum of 17 in. (43 cm) width X 14 in. (36 cm) depth. Minimum height of the adult chair backrest is 9 in. (23 cm).

- 7 - Wrap the front set of the booster straps under the adult chair. Wrap the back set of the booster straps around the back of the adult chair. Ensure that the straps are not twisted.

- 8 - Buckle the safety buckle on the back of the adult chair.

- 9 - Tighten the strap on the adult chair by pulling on the tail end of the strap to ensure that the seat is snugly attached to the adult chair.

- 10 - Buckle the safety buckle on the underside of the adult chair.

- 11 - Tighten the strap on the adult chair by pulling on the tail end of the strap to ensure that the seat is snugly attached to the adult chair.

(Using Toddler Booster continued on pg. 36)

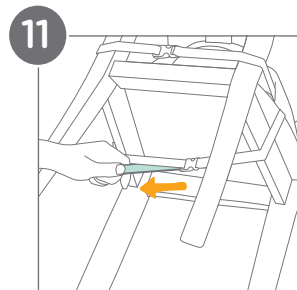
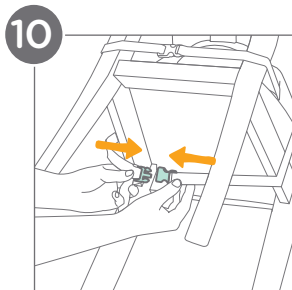
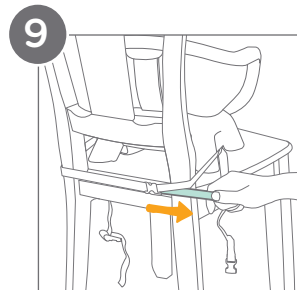
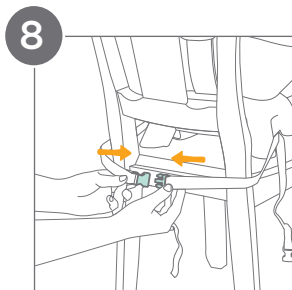
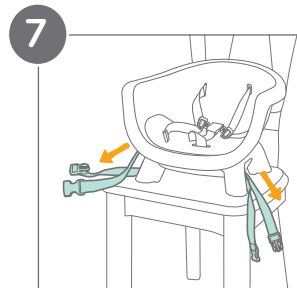
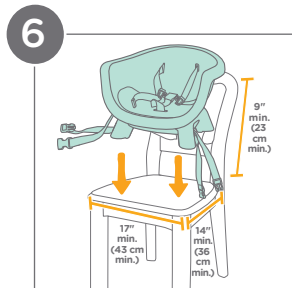

Using Toddler Booster: (cont.)

- 12** - Pull on the front and sides of the seat to ensure that the seat straps are snug and the infant booster seat does not move side-to-side or front-to-back.
- 13** - To secure child, insert both of the waist belt buckles into the crotch buckle (A).

A “clicking” sound will confirm that the buckles are properly locked in place. (B).

Pull the waist harness strap (C) to tighten the waist harness. Press the button (D) on the waist belt buckle and pull to loosen the waist harness strap (C).

14 - **IMPORTANT:** Until child is able to get in and out of the toddler booster seat without help, the child **MUST** be secured in the toddler booster seat at **ALL TIMES** by the restraints. The tray is **NOT** designed to hold the child in the seat.

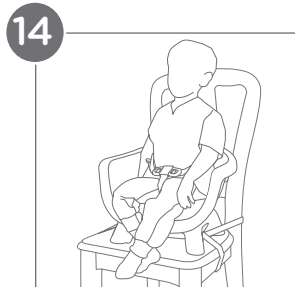
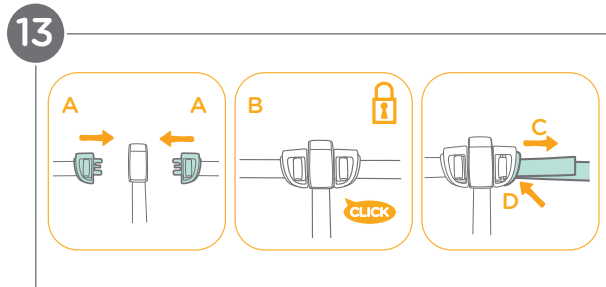
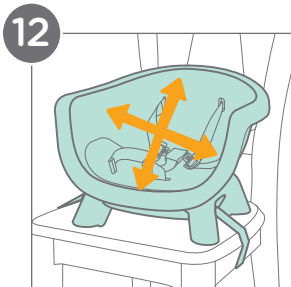

Storing Booster Straps:

- 1 - Place the booster straps back inside the storage boxes.
- 2 - Close the storage boxes. A “clicking” sound will confirm that the storage boxes are properly closed.

The storage boxes will not fully close unless the booster straps and buckles are fully inside.

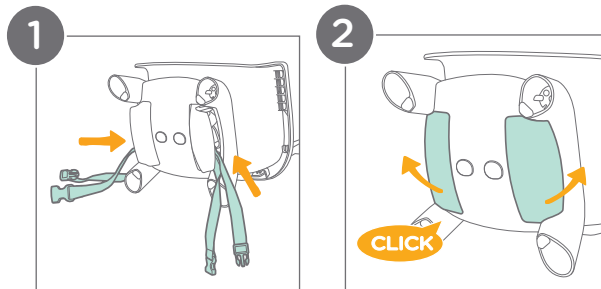

Using Youth Chair:

- 1 - Before using as a youth chair, it is necessary to remove the backrest, waist harness straps, and crotch strap. Store them away from children's reach (see steps 2-6 below.)
- 2 - Press the center button to release the restraint buckle.
- 3 - Press the recline adjustment lever (A) and adjust the backrest to the most reclined position (B).
- 4 - Press the crotch strap release button (C) to remove the crotch strap (D). Reset the seat recline to fully upright.

 The crotch strap can be removed without the backrest attached.

(Using Youth Chair continued on pg. 42)

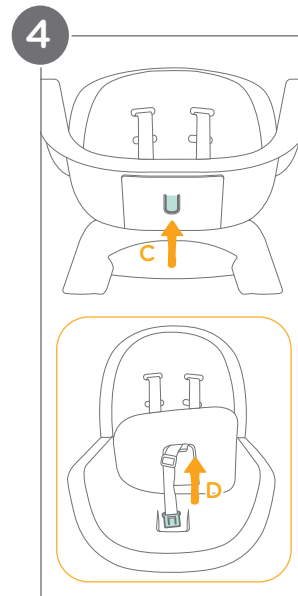
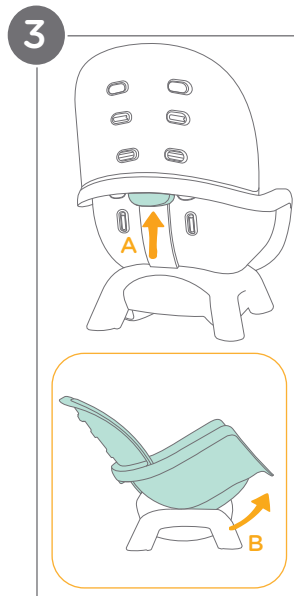
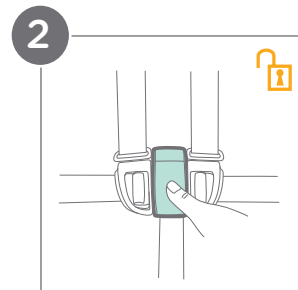
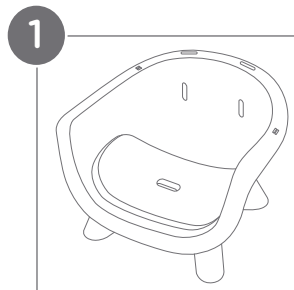

Using Youth Chair: (cont.)

- 5 - If the backrest is attached, pull the backrest release tabs back and rotate the backrest forward to remove it, along with the shoulder straps.
- 6 - When removing the backrest (A), thread the waist harness straps out of the seat (B).
- 7 - Flip the seat upside down.
- 8 - If the youth chair feet are in the storage boxes, press the storage box release buttons (A) under the seat to open them. Pull out the youth chair feet from both sides (B).
- 9 - Close the storage boxes, then install all four upper legs onto the seat. The upper legs cannot be installed unless the storage boxes are fully closed.

(Using Youth Chair continued on pg. 44)

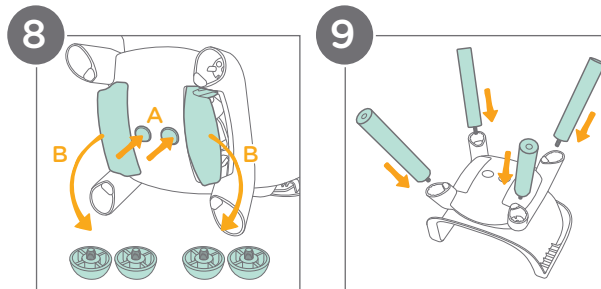
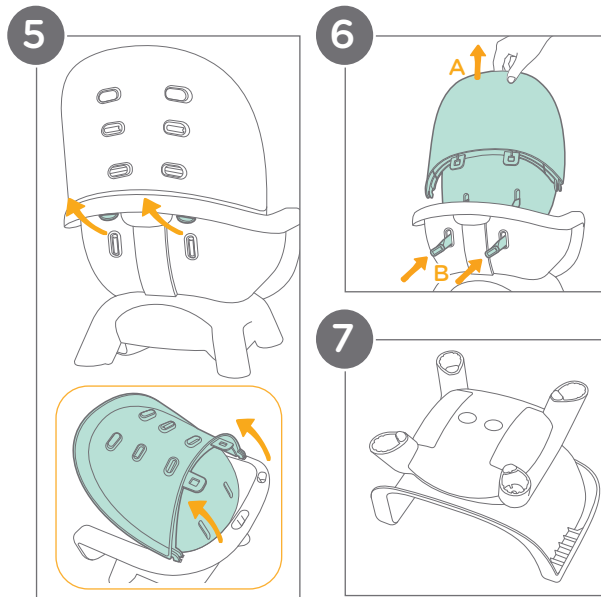

Using Youth Chair: (cont.)

10 - Rotate the upper legs clockwise until they stop rotating.

11 - Align the youth chair feet with the openings on the bottom of the upper legs.

12 - Rotate the youth chair feet clockwise until they stop rotating.

13 - Flip the seat right-side up. Youth chair mode is ready for use.

 When not using the youth chair feet, they can be kept in the storage boxes on the underside of the seat.

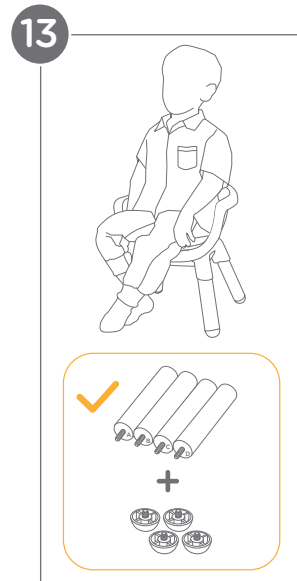
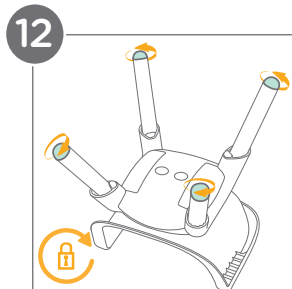
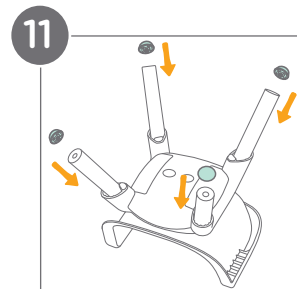
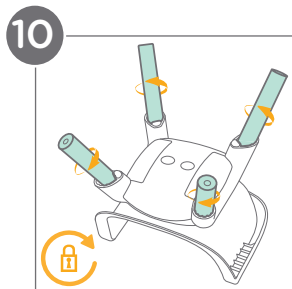

Using Youth Stool

- 1 - Before using as a youth stool, it is necessary to remove the backrest, waist harness straps, and the crotch strap. Store them away from children's reach (see pgs. 40-43, steps 2-6).

Install the upper and lower legs for **table height**.

Install the upper, middle, and lower legs for **counter height**.

(See pgs. 12-15 for leg installation help).

IMPORTANT: The basket/footrest **MUST** be installed.
For basket/footrest installation help, see pg. 12.

Fully tighten all the legs. Ensure that there are no gaps between the legs to avoid instability.

1



table height

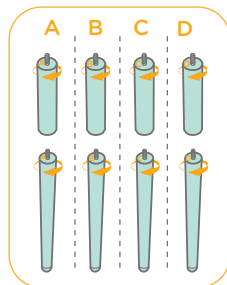

counter height

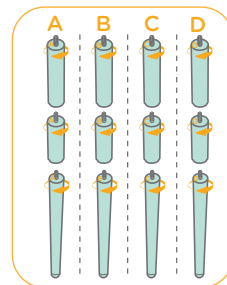

Removing Seat Pad & Back Pad:

- 1 - Press the center button to release the restraint buckle.
- 2 - Thread the waist and shoulder harness straps out of the back pad.
- 3 - Remove the back pad by pulling it forward.
- 4 - Remove the seat pad by pulling it up while threading the crotch buckle through the seat pad.

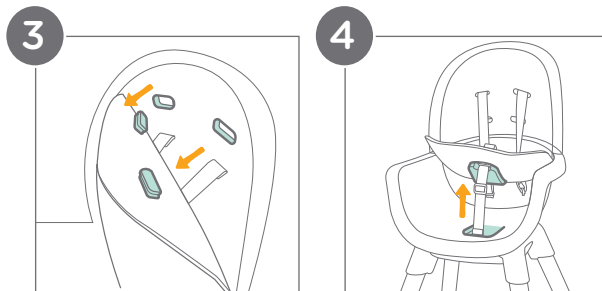
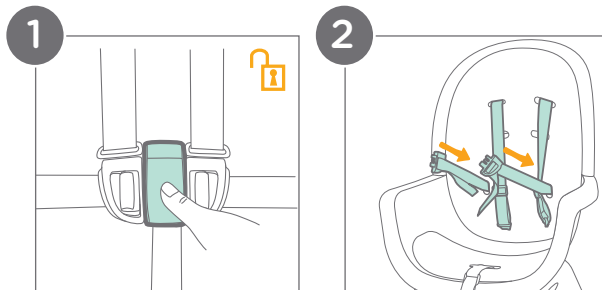

Removing Basket:

- 5 - Turn the highchair upside down. Unsnap the two straps from the basket and unwrap them from the metal frame (A). Unthread the middle strap from the slot in the footrest (B).
- 6 - Unscrew the two back legs (C) from the highchair and slide the basket off for cleaning (D).

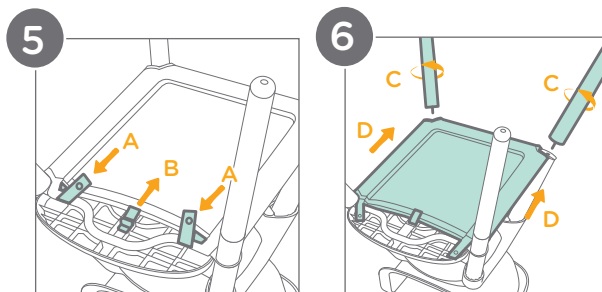

To reattach the basket, repeat the above steps in reverse order.

Care & Maintenance:

Cleaning:

The tray insert is dishwasher safe for **TOP RACK ONLY**.

The tray is NOT dishwasher safe. Wipe with a damp cloth and mild soap.

The back pad and the seat pad can be spot cleaned with a damp cloth and mild soap. **DO NOT** use bleach. **DO NOT** put the pads in the dryer.

To clean the basket softgoods, refer to the care tags on the product.

To clean the seat, frame, and legs wipe them with a damp cloth and mild soap. Wipe off any traces of moisture with a dry cloth.

DO NOT use undiluted detergent, alcohol, or any other organic solvent to wash the product. It may cause damage to the product.

Maintenance:

Worn parts: Replace any worn or damaged parts. Use only Joie replacement parts.

Contact Joie Consumer Service at:

Email: info.us@joiebaby.com • Phone: 1-866-798-7866

Storage:

If the product is not in use for a long period of time, store it where your child cannot access it.

Joie™

Effortlessly happy.

Helping parents be their best
with worry-free baby gear.