

Joie™

Instruction Manual

ginger™

4-in-1 pramette stroller

Weight: birth up to 50 lb. (22.7 kg)

Height: birth up to 45 in. (114.3 cm)

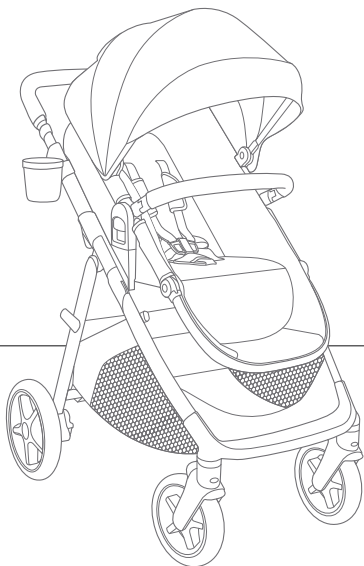

IMPORTANT!

Read all instructions before assembling and using the stroller.
Keep instructions for future use.

Contents:

- 3 Warranty Information
- 4 Warnings
- 8 Parts List
- 10 Opening Stroller
- 10 Attaching & Detaching Front Wheels
- 12 Attaching & Detaching Rear Wheels
- 12 Attaching & Detaching Canopy
- 14 Attaching & Detaching Cup Holder
- 16 Attaching & Detaching Arm Bar
- 18 Securing Your Child
- 22 Adjusting Recline
- 22 Adjusting Calf Support
- 24 Using Pramette
- 26 Using Front Swivel Locks
- 26 Using Brake
- 28 Using Canopy
- 28 Removing Harness & Buckle Covers
- 30 Adjusting Handlebar
- 30 Adjusting Seat Height
- 32 Using Reversible Seat
- 34 Folding Stroller
- 36 Using Accessories
- 38 Care & Maintenance

Child Usage Requirements

This stroller is suitable for use with children who meet the following requirements:

- Weight: birth up to 50 lb. (22.7 kg)
- Height: birth up to 45 in. (114.3 cm)

Warranty Information:

Product Registration

Please fill in the information below. The model number and the date of manufacture are located on a label on the stroller frame. Fill out the prepaid registration postcard attached to the product and mail it today. To register your product online, please visit: <https://joiebaby.com/us/register-gear>.

Model Name: _____
Model Number: _____
Date of Manufacture: _____
Date of Purchase: _____

register your
product online



Limited Warranty

We have purposely designed our high-quality products so that they can grow with both your child and your family. Because we stand by our product, our gear is covered by a custom limited warranty per product, starting from the day it was purchased. Please have the proof of purchase, model number and date of manufacture available when you contact us. For warranty information please visit: www.joiebaby.com.

Contact

In the USA:

Joie Baby USA Consumer Service Contact Info

Address: 70 Thousand Oaks Blvd., Morgantown, PA 19543

In Canada:

Joie B  b   Canada Consumer Service Contact Info

Address: PO Box 96528 RPO Brunswick, Kirkland, Quebec H9H 5L4

Email: info.us@joiebaby.com

Phone: 1-866-798-7866

WARNING

Failure to follow these warnings and instructions could result in serious injury or death.

- **NEVER** leave child unattended.
- **Choking Hazard:** Keep small parts away from children. These components may pose a choking hazard.
- **Suffocation Risk:** Remove all plastic covers before using the stroller. Destroy these covers or keep them completely out of reach of babies and children.
- **Broken Stroller:** If the stroller becomes damaged or broken, **STOP** using it immediately. A damaged stroller can be unsafe.
- **Modification Warning:** **DO NOT** modify the stroller in any way unless specified in the manual. Unauthorized changes can compromise safety.
- **Genuine Parts Only:** Use **ONLY** genuine parts and accessories from Joie.
- **Overloading, incorrect folding, and using accessories other than those approved by Joie,** e.g. child seats, bag hooks, rain covers, buggy boards, etc., may damage or make the stroller unsafe.

WARNING

Failure to follow these warnings and instructions could result in serious injury or death.

- **Weight & Height Limits:** This stroller is only suitable for children up to 50 lb. (22.7 kg) and 45 in. (114.3 cm) tall. Exceeding these limits can cause wear and tear, potentially leading to an unstable stroller.
- **Single Child Use:** This stroller is designed for one child only. **NEVER** transport more than one child at a time.
- **To prevent a hazardous, unstable condition, DO NOT** place more than 10 lb. (4.5 kg) in the storage basket and **NEVER** place purses, shopping bags, parcels, or other items on the handle or canopy.
- **DO NOT** use the storage basket as a child carrier.
- **Avoid serious injury from falling or sliding out.** **ALWAYS** use the harness. After fastening buckles, adjust belts to get a snug fit around your child.
- **Avoid Finger Entrapment:** Use care when folding and unfolding the stroller. Ensure that the stroller is fully erected and locked before allowing your child near the stroller.

WARNING

Failure to follow these warnings and instructions could result in serious injury or death.

- **Strangulation Hazard: DO NOT** place items with a string around your child's neck, suspend strings from the stroller, or attach strings to toys.
- **DO NOT** let your child play with the stroller.
- **ALWAYS** keep your child in view while in the stroller.
- **NEVER** allow your child to stand on the stroller.
- **The parking brake MUST be engaged** when the stroller is stopped and when placing and removing child.
- **Negotiate curbs and rough ground carefully.** Repeated impact could cause damage to the stroller.
- **The stroller is to be used only at walking speed** and is not intended for use while jogging, skating, etc.
- **NEVER** use the stroller on stairs or escalators. You may suddenly lose control of the stroller or your child may fall out.

WARNING

Failure to follow these warnings and instructions could result in serious injury or death.

- **The stroller does not replace a crib or a bed.** Should your child need to sleep, they should be placed in a crib or sleeping area based on your child's requirements.
- **ALWAYS** allow the fabric to dry naturally away from direct heat.
- **DO NOT** leave the stroller exposed near a strong source of heat, i.e. a radiator or open fire, or store the stroller in a damp place.
- **To avoid burns, NEVER** put hot liquids in your cup holder.
- **To prevent a hazardous, unstable condition, DO NOT** place more than 1 lb. (0.5 kg) in the cup holder.
- **When using the stroller frame with a Joie car seat,** refer to the child usage requirements listed in the car seat instruction manual.
- **NEVER** use in pramette mode unless the buckle on the bottom of the seat is released and the calf support is in the raised position.

Parts List:

Please make sure there are no missing parts. Please contact Joie Consumer Service if anything is missing.

- 1 Stroller Frame
- 2 Infant Car Seat Adapters
- 3 Front Wheels
- 4 Rear Wheels
- 5 Arm Bar
- 6 Handlebar
- 7 Cup Holder
- 8 Restraint Buckle
- 9 Storage Basket
- 10 Canopy
- 11 Seat
- 12 Shoulder Harness
- 13 Arm Bar Release Buttons
- 14 Calf Support
- 15 Footrest
- 16 Seat Release Button (x2)
- 17 Calf Support Adjustment Button (x2)
- 18 Front Swivel Lock (x2)
- 19 Canopy Window Cover
- 20 Pramette Seat Lever
- 21 Handlebar Sliding Lock (x2)
- 22 Fold Release Tab (x2)
- 23 Recline Adjuster
- 24 Seat Height Adjustment Button (x2)
- 25 Storage Latch
- 26 Brake

Parts List:

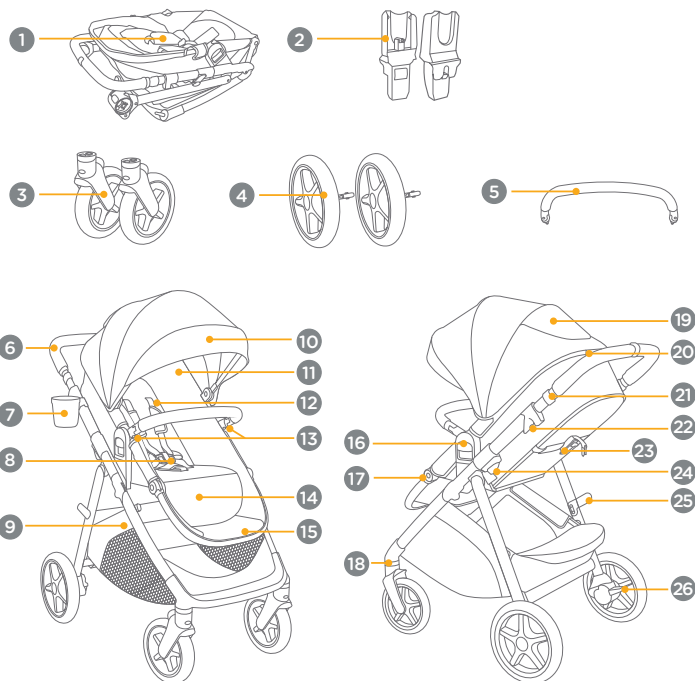

Opening Stroller:

- 1 - Separate the storage latch from the storage mount.
- 2 - Lift the handlebar upwards. A “clicking” sound will confirm that the stroller is completely open.
- 3 - For the first use of the stroller, press the footrest down to reset it (A), then connect the hook and loop fastener under the calf support (B).

IMPORTANT: Check that the stroller is completely open by pushing down on the handlebar.

Attaching & Detaching Front Wheels:

4- Attaching the Front Wheels:

Insert the front wheels into the front legs.

A “clicking” sound will confirm that the wheels are properly locked in place.

IMPORTANT: Safety Check: ALWAYS pull on the wheels after attachment to ensure that they are securely fastened.

5- Detaching the Front Wheels:

To remove the front wheels, press the release button (C) on each wheel and pull the front wheel away from the front leg (D).

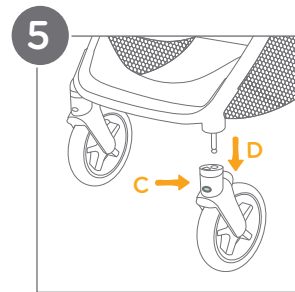
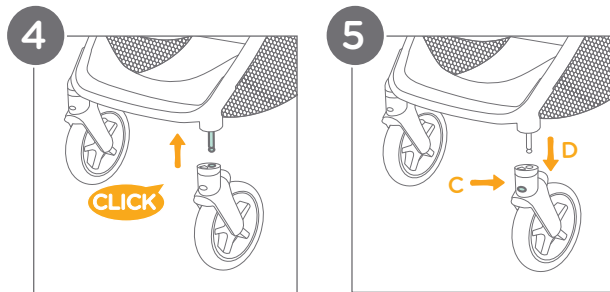
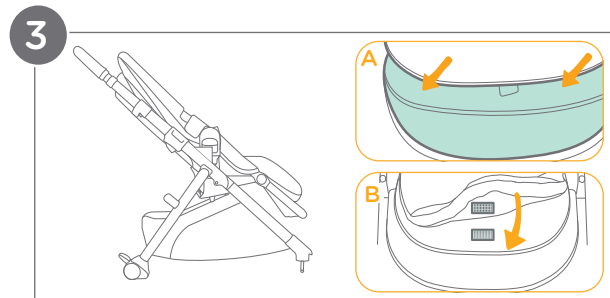
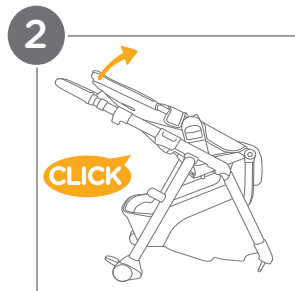
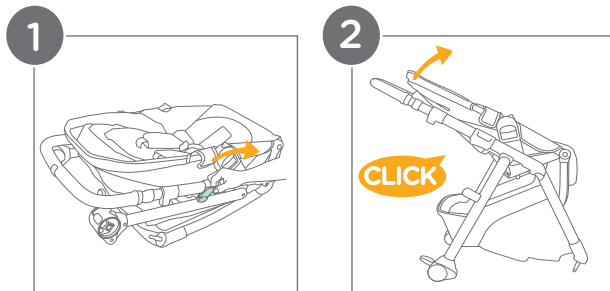

Attaching & Detaching Rear Wheels:

1 - Attaching the Rear Wheels:

Insert the rear wheels into the rear legs.

A “clicking” sound will confirm that the wheels are properly locked in place.

IMPORTANT: Safety Check: **ALWAYS** pull on the wheels after attachment to ensure that they are securely fastened.

2 - Detaching the Rear Wheels:

To remove the rear wheels, press the release button (A) on each wheel and pull the rear wheel away from the rear leg (B).

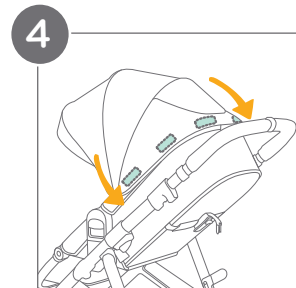
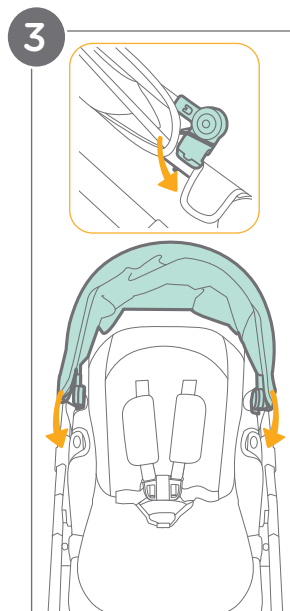
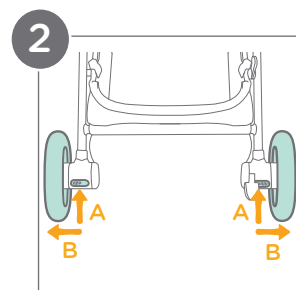
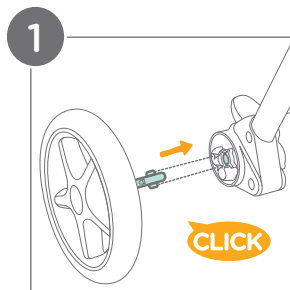

Attaching & Detaching Canopy:

3 - Clip the canopy mounts to both sides of the stroller frame. Ensure that the canopy's elastic loops are attached to the canopy mounts.

4 - Attach the hook and loop fasteners on the rear flap of the canopy to the top of the seat.

To detach the canopy, repeat the above steps in reverse order.

Attaching & Detaching Cup Holder:

- 1 - Wrap the cup holder clasp around the right side of the stroller frame.
- 2 - A “clicking” sound will confirm that the cup holder clasp is properly secured.
- 3 - To remove the cup holder, unhook the cup holder clasp from around the stroller frame and remove.

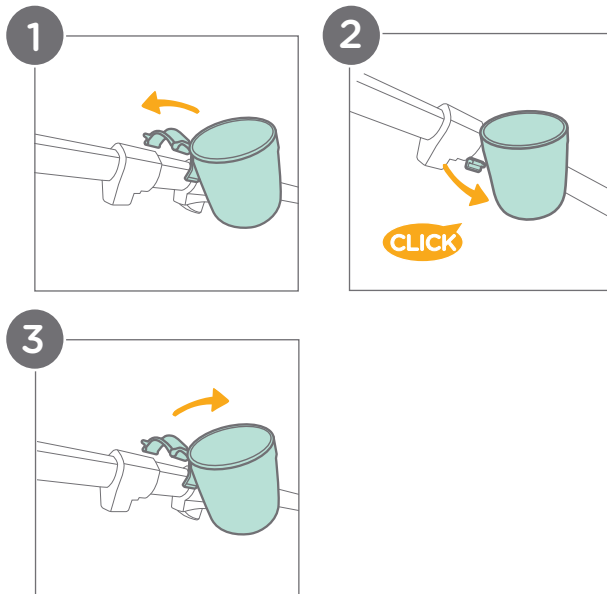

Attaching & Detaching Arm Bar:

1 - Attaching the Arm Bar:

Insert both ends of the arm bar into the arm bar mounts. A “clicking” sound will confirm that the arm bar is properly locked in place.

2 - Detaching the Arm Bar:

To remove the arm bar, press the arm bar release buttons (A) and pull the arm bar out (B).

3 - Rotating the Arm Bar:

Press and hold one arm bar release button (C) while lifting up to rotate the arm bar at the arm bar mount on the other side of the stroller (D).

IMPORTANT: ALWAYS secure the child with the harness.

The arm bar is not a restraint device.

DO NOT lift the stroller by the arm bar. This can cause damage or injury.

Use care when attaching the arm bar on the stroller with a child in the stroller.

CAREGIVER MUST ALWAYS help the child get into and out of the stroller.

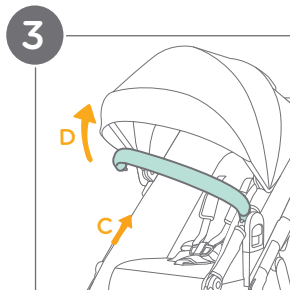
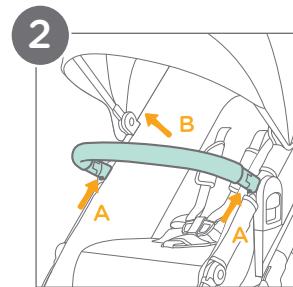
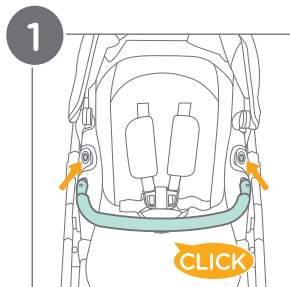

Securing Your Child:

1 - Releasing the Restraint Buckle:

Locate the button in the center of the restraint buckle and press it firmly to release the harness straps.

2 - Locking the Restraint Buckle:

Slide the shoulder harness buckle into the waist belt buckle (A). Insert the combined buckles together into the center buckle (B). A “clicking” sound will confirm that the restraint buckle is properly locked in place (C).

IMPORTANT: ALWAYS engage the brake: This is crucial whenever the stroller is stopped, especially when placing or removing your child. A parked stroller with a disengaged brake can roll away, posing a serious fall hazard.

Secure your child with the harness: NEVER leave your child unbuckled in the stroller. A secure harness is essential to prevent them from falling or sliding out.

Proper harness adjustment: Ensure that the harness straps are snug but comfortable. The space between the child and the harness straps should be about a 1/2 inch (1 cm).

Shoulder strap positioning: NEVER cross the shoulder straps. **ALWAYS** keep them straight over your child's shoulders to avoid putting pressure on the child's neck.

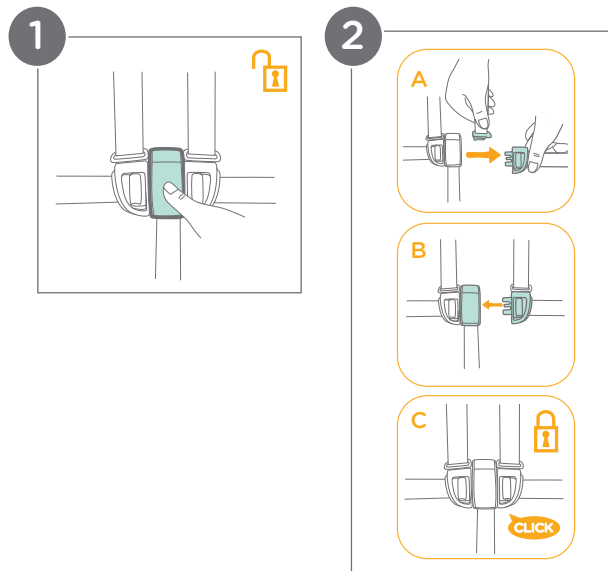

Shoulder Harness Height Adjustment:

- 1 - Locate the shoulder harness anchors (A) on the back of the seat.
- 2 - Turn the harness anchor to be in line with the harness strap. Thread it through the shoulder harness slot from back to front.
- 3 - Re-thread the harness anchor through the correct slot from front to back. Ensure that both sides are adjusted to slots at the same height.
- 4 - Use the slide adjuster (B) to adjust the length of the shoulder harness straps. Pull the waist harness strap (C) to tighten the waist harness. Press the button (D) on the waist belt buckle and pull to loosen the waist harness strap (C).

IMPORTANT: DO NOT adjust the harness anchors with a child in the stroller.

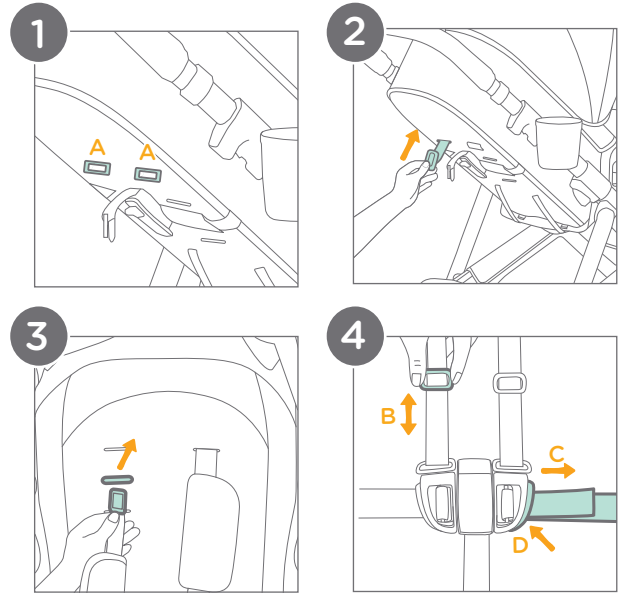

Adjusting Recline:

1 - Reclining the Backrest:

Press the button (A) in the center of the recline adjuster while pulling the backrest backward (B).

2 - Raising the Backrest:

Push the backrest forward (C) while pulling the webbing (D) at the end of the recline adjuster.

IMPORTANT: When making adjustments to the recline, make sure the child's head, arms, and legs are clear of moving seat parts and the stroller frame to prevent injury.

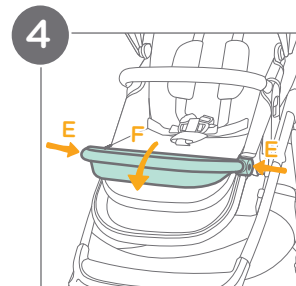
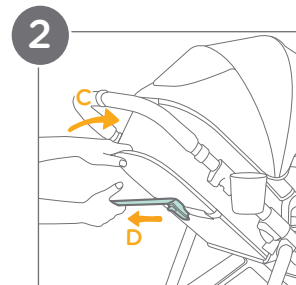
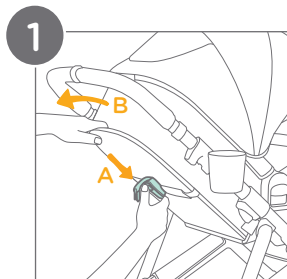

Adjusting Calf Support:

3 - Raising the Calf Support:

Lift the 2-position calf support upwards. A “clicking” sound will indicate that it is properly locked in place.

4 - Lowering the Calf Support:

Press the calf support adjustment buttons on both sides of the calf support (E) and rotate the calf support downwards (F).

Using Pramette:

For Pramette Mode:

- 1 - On the underside of the seat, unbuckle the calf support clip and then recline the seat fully. (See page 22 for instructions on reclining the seat.)
- 2 - On the back of the seat, pull the pramette seat lever out (A), while pulling down on seat to pivot the seat flat (B).
- 3 - To switch the direction of the pramette, squeeze the seat release buttons (C) while lifting the pramette (D). Turn the pramette to reverse direction and then reinsert the pramette into the mounts. (See page 32 for more detailed instructions.)
- 4 - The pramette can be used rearward or forward facing.

IMPORTANT: DO NOT use the arm bar as a carry handle when in pramette mode.

The pramette has been designed to use from birth.

STOP using this mode when the child begins trying to push up on their hands and knees.

DO NOT use an additional mattress in pramette mode.

DO NOT raise the backrest in pramette mode.

ALWAYS use the harness in pramette mode.

DO NOT reverse the seat with a child in the stroller.

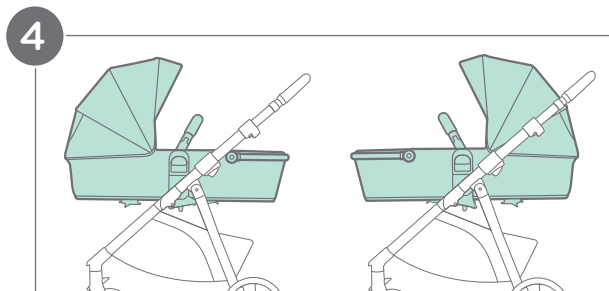
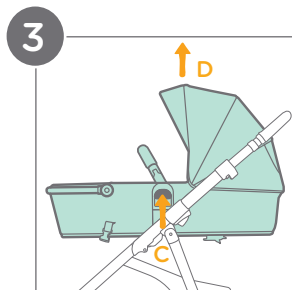
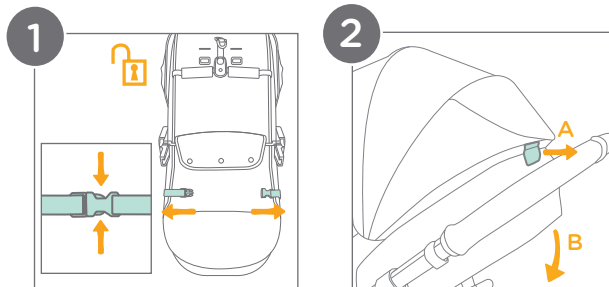

Using Front Swivel Locks:

1 - Locking the Wheels:

Ensure that the front wheels are positioned straight ahead, not angled to the side or turned around.

The swivel locks are located on the backside of each wheel.

Rotate each swivel lock clockwise. A “clicking” sound will confirm that the wheels are properly locked in a straight position.

Unlocking the Wheels:

Rotate each swivel lock counter-clockwise. The wheels will swivel freely again.

 It is recommended to use the swivel locks on uneven surfaces.

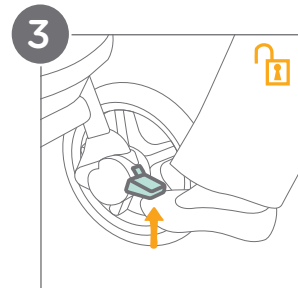
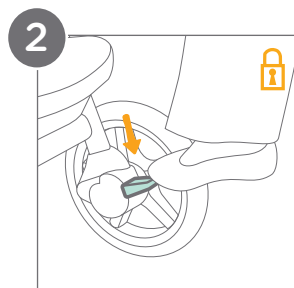
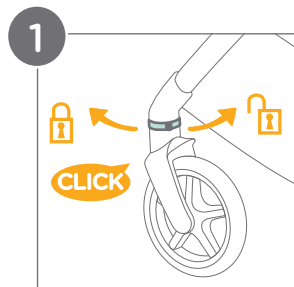

Using Brake:

2 - To lock the rear wheels, press the brake downwards.

3 - To unlock the rear wheels, lift the brake upwards.

IMPORTANT: ALWAYS set the brake when the stroller is not moving.

Using Canopy:

Opening and Closing the Canopy:

- 1 - To open, pull the canopy forward toward the front of the seat. To close, push the canopy back.

Ventilation:

- 2 - For additional airflow, flip the canopy window cover up.

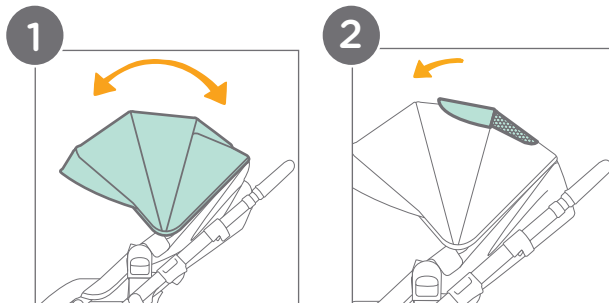

Removing Harness & Buckle Covers:

3 - Removing the Shoulder Harness Covers:

Unsnap the shoulder harness covers. Release the restraint buckle and slide the shoulder harness buckles out of the waist belt buckle. Unthread the shoulder harness straps from the elastic on the inside of the shoulder harness covers (A). Slide the harness covers off of the straps by pulling them down (B).

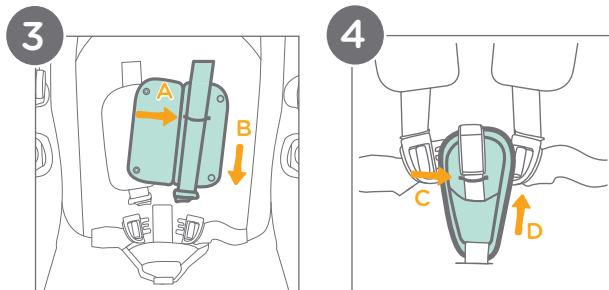

4 - Removing the Crotch Buckle Cover:

Unbuckle the harness straps. Unthread the center buckle from the elastic (C) on the inside of the crotch buckle cover. Lift the crotch buckle cover up to remove it (D).

To reattach the covers, repeat the above steps in reverse order.

Adjusting Handlebar:

There are 3 handlebar positions:

- 1 - Pull the handlebar sliding locks (A) upwards on both sides of the handlebar and pull or push the handlebar to adjust the height to the desired position (B).

Release the handlebar sliding locks to lock the handlebar in place. A “clicking” sound will confirm that the handlebar is properly locked in place.

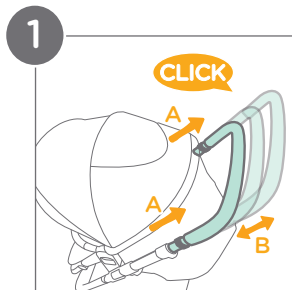

Adjusting Seat Height:

There are 3 seat height positions:

- 2 - To raise the seat height, pull up on the seat.

A “clicking” sound will confirm that the seat is properly locked in place.

IMPORTANT: DO NOT raise the seat by pulling up on the arm bar.

- 3 - To lower the seat height, squeeze and hold the seat height adjustment buttons (C) and push down on the seat.

- 4 - Lock the seat in position by releasing the height adjustment buttons. A “clicking” sound will confirm that the seat is properly locked in place.

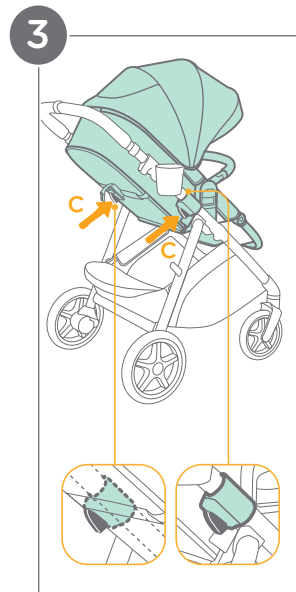

Using Reversible Seat:

The seat is reversible so the child can face rearward or forward.

- 1 - Squeeze the seat release buttons on both sides of the seat (A) while lifting the seat up (B). Turn the seat to the reverse the direction and then reinsert the seat onto the seat mounts. A “clicking” sound will confirm that the seat is properly locked in place.
- 2 - The seat mounts must be level for the seat to attach to the frame.
- 3 - If the mounts are uneven:
- 4 - Squeeze and hold the seat height adjustment buttons (C) to unlock the seat mount.
- 5 - Pull up or push down on the seat mounts to adjust them to the same seat height. Lock the seat mounts into position by releasing the seat height adjustment buttons.

IMPORTANT: DO NOT reverse the seat with a child in the stroller.

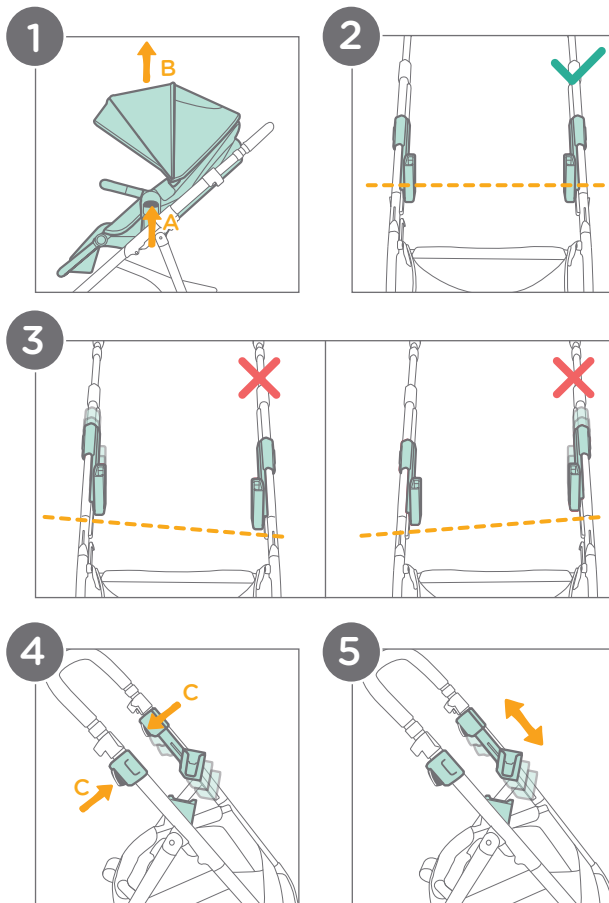

Folding Stroller:

Before folding, make sure the canopy is completely closed and the seat is in the forward-facing, upright position. For instructions on switching the direction of the seat, see pg. 32.

- 1 - Press in the secondary fold lock button located on the left fold release tab (A). Pull upwards on both fold release tabs (B) simultaneously and hold them in position.
- 2 - Push down on the handlebar to fold the stroller. If the seat is not in the highest position, it will slide upwards.
- 3 - The fold latch will engage automatically when the stroller is fully folded.

IMPORTANT: DO NOT fold the stroller with the seat rear-facing (illustration 4).

DO NOT fold the stroller with the front wheels locked.

DO NOT fold the stroller while in pramette mode.

 **The stroller can stand** when folded when the handlebar is in the middle position.

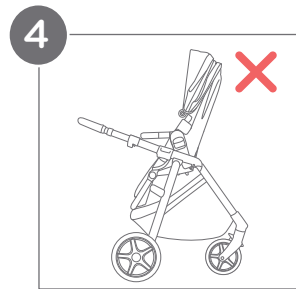
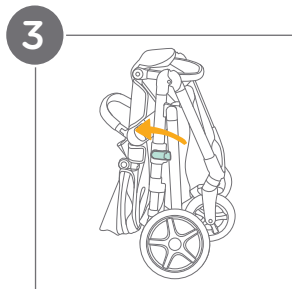
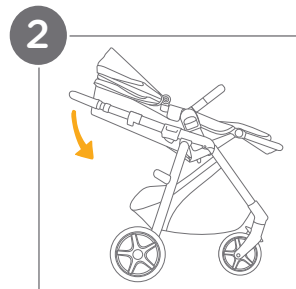
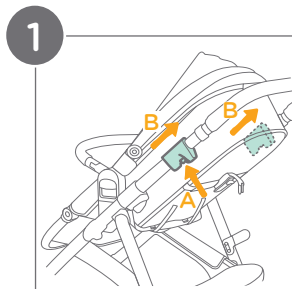

Using Accessories:

For information about using your Joie infant car seat, refer to the instruction manual included with the infant car seat.

Using with a Joie Infant Car Seat

- 1 - To use with a Joie infant car seat, first remove the stroller seat. Squeeze the seat release buttons (A) on both sides of the seat while lifting the seat up (B).
- 2 - Attach the included infant car seat adapters to the seat mounts. A “clicking” sound will confirm that the adapters are properly locked in place.
- 3 - Attach the infant car seat by placing the car seat onto the adapters.
- 4 - Check that the infant car seat is securely attached to the stroller by pulling up on the car seat.
- 5 - To remove the infant car seat, first press the car seat release buttons (C), and then lift the car seat upwards (D).
- 6 - To remove the adapters, pull out the release tabs (E) then lift the adapters upwards (F).

IMPORTANT: DO NOT fold the stroller while the car seat is attached.

Fall Hazard: ALWAYS check that the infant car seat is securely attached to the stroller by pulling up on the car seat.

ALWAYS secure your child with the car seat harness when using the car seat.

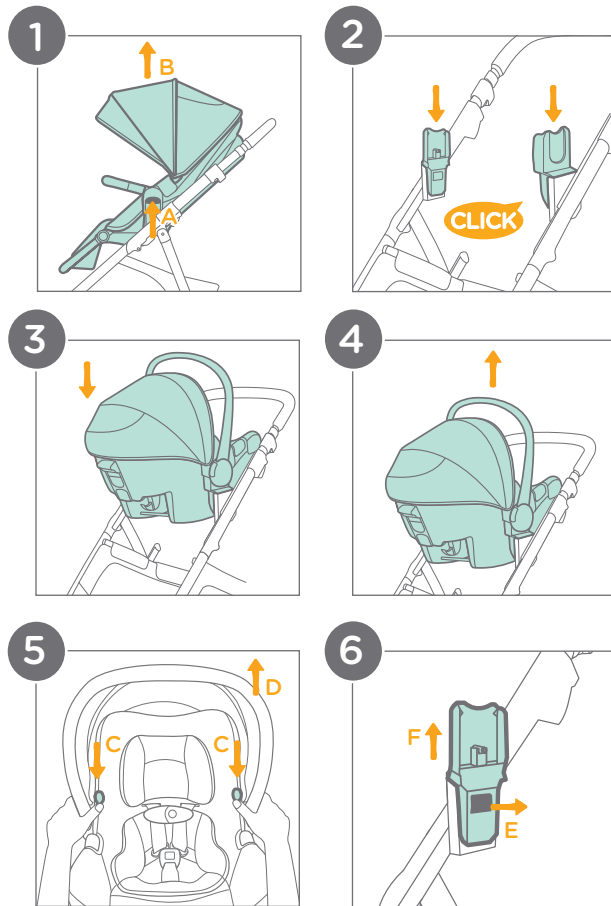

Care & Maintenance:

Cleaning:

Seat pad: Spot clean with a sponge and soapy water.

Stroller frame: Wipe clean with a solution of warm water and mild household soap. Avoid bleach and harsh detergents.

Plastic parts: Periodically wipe clean with a damp cloth.

Metal parts: After contact with water, thoroughly dry the metal parts to prevent rust.

Maintenance:

Regular inspection: Check the stroller regularly for loose or missing parts. Discontinue use if parts are loose or missing.

Worn parts: Replace any worn or damaged parts. Use only Joie replacement parts.

Torn material or stitching: Repair or replace torn fabric or stitching. Use only Joie replacement fabrics.

Contact Joie Consumer Service at:

Email: info.us@joiebaby.com • Phone: 1-866-798-7866

Storage:

Extreme weather exposure: Avoid excessive sun or heat exposure to prevent fading or warping of parts. Avoid storing outside or in cold conditions.

Drying after use: If the stroller gets wet, open the canopy and allow it to dry completely before storing.

Wheel Maintenance:

Squeaking wheels: Apply a light coat of lubricating oil (e.g., silicone spray, anti-rust oil, or sewing machine oil) directly to the axle and wheel assembly to eliminate squeaking.

Beach Use:

After beach use: Thoroughly clean the stroller to remove sand and salt from the mechanisms and wheels. This helps to prevent rust.

Cup Holder:

Use mild detergent and warm water.

For a more thorough cleaning, remove the cup holder (see pg. 14).

The cup holder can be placed on the top rack of your dishwasher for convenient cleaning.

Joie™

Effortlessly happy.

Helping parents be their best
with worry-free baby gear.