

Joie™

0+ (0-13kg)

gemm™

汽車用兒童保護裝置

## 使用說明書

本產品符合安全標準  
CNS 11497及歐盟標準  
ECE R44測試和認證  
組裝及使用本產品前  
請先閱讀說明書全文

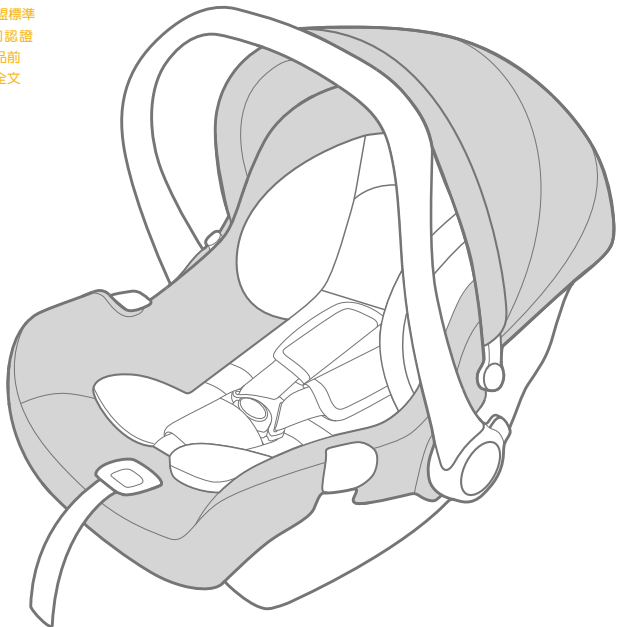

# 恭喜您

恭喜您成為Joie家族的一員！很高興能與您的寶寶共度行車旅程。乘坐本產品時，您的寶寶享受的是一台高品質和通過安全標準及歐盟安全標準檢測的0+級嬰兒提籃。這台嬰兒提籃適用於體重13公斤(約1.5歲)以下的寶寶。請仔細研讀並依照本說明書的指示操作，如此才能保障並提供您的寶寶一個安全又舒適的行車旅程。

## 請確定

請確定您的汽車有三點式安全帶裝置。依照各種汽車的品牌、年份和型號，安全帶可以有不同的設計和長度。本嬰兒提籃適用於符合歐盟安全標準ECE R16或安全標準CNS 3972的三點式安全帶的汽車座椅，因本嬰兒提籃是依標準CNS 11497及歐盟標準ECE R44去做測試和認證的。

## 嬰兒汽車安全座椅

！重要：請仔細閱讀並妥善保存本說明書，以便日後參考。  
請將本說明書存放在嬰兒提籃上(如圖)。安裝和使用本產品前，請先閱讀說明書全文。



# 目錄

## 參照圖示 1-7

### 中文

警告	9
緊急情況處理	11
產品資訊	11
產品組件及各部位名稱	13
安裝注意事項	13
飛機上使用	14
調整把手	14
肩帶正確位置	14
調整肩帶高度	15
實實乘坐	15
安裝嬰兒提籃	16
拆卸遮陽篷和座墊	17
保養維護與保固	18

### English

20-34

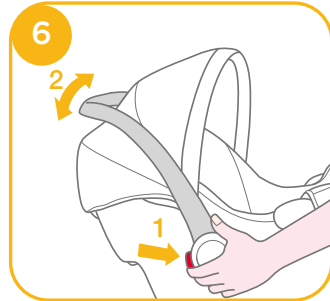
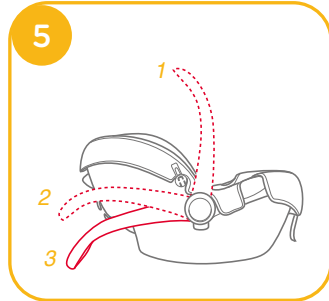
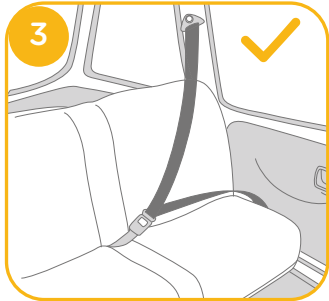
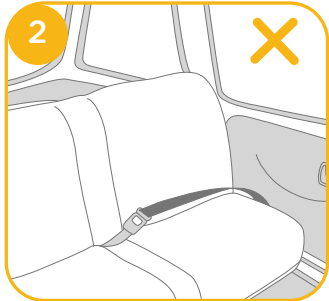
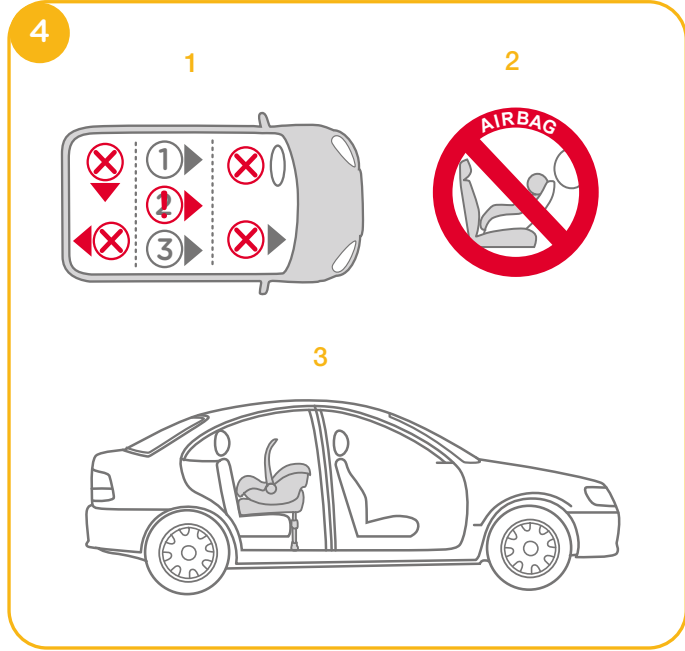
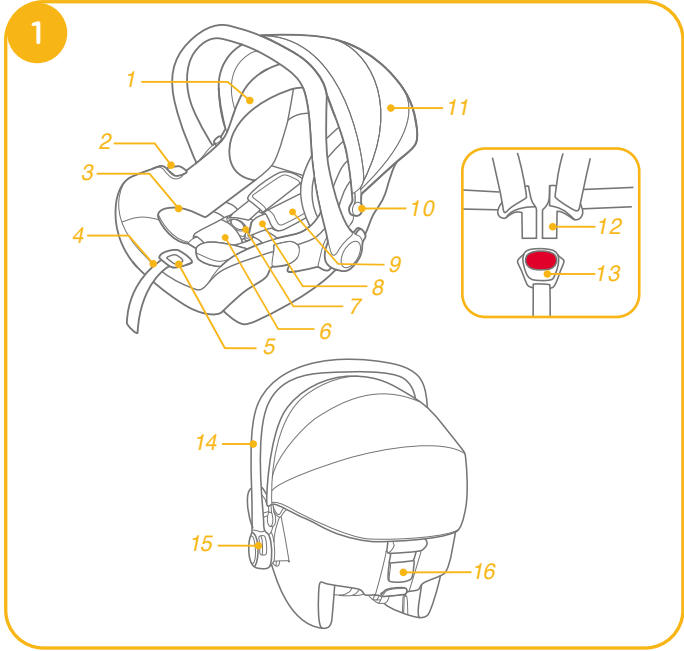

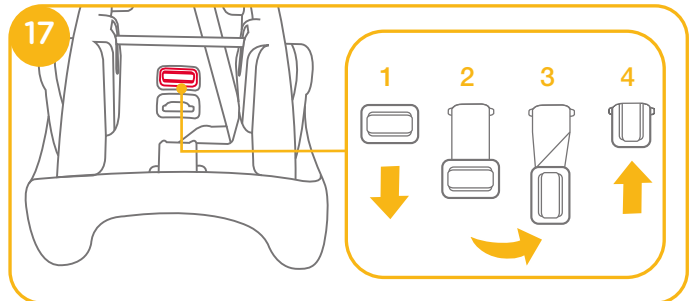
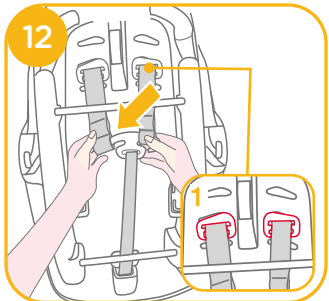
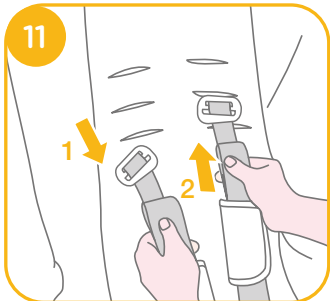
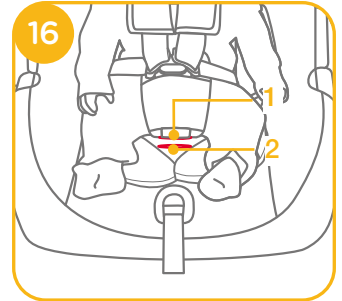
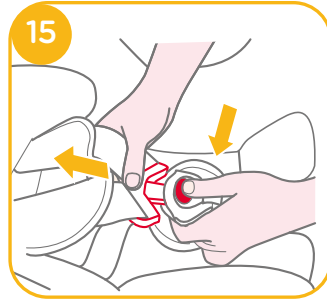
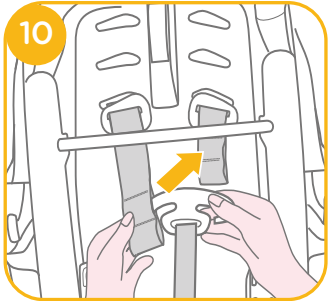
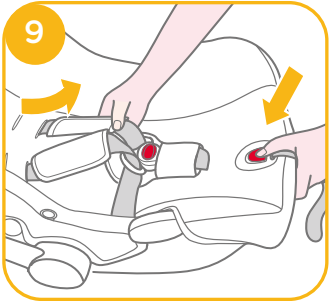
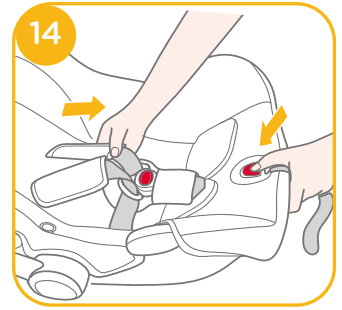
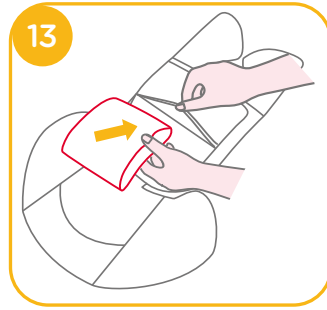

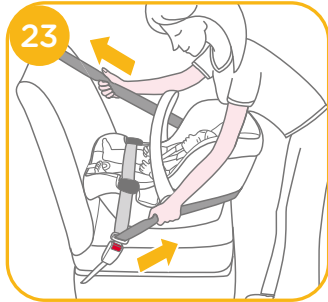
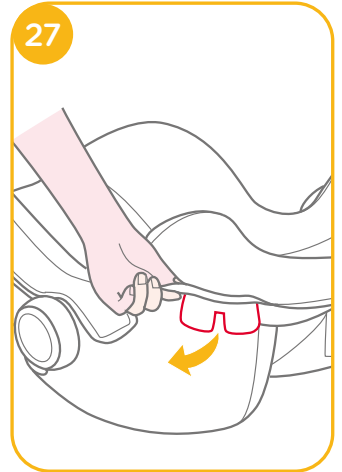
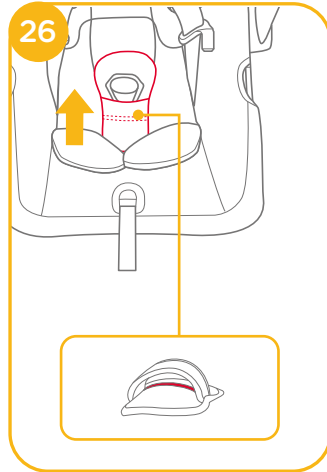
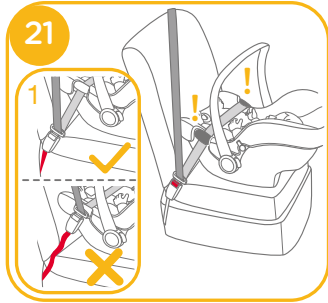
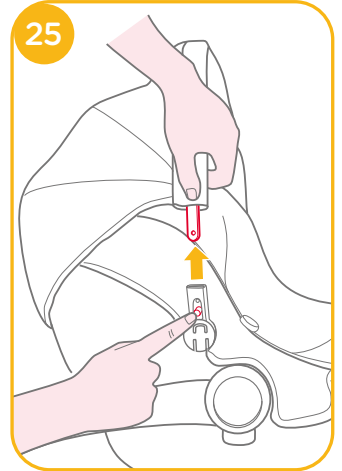
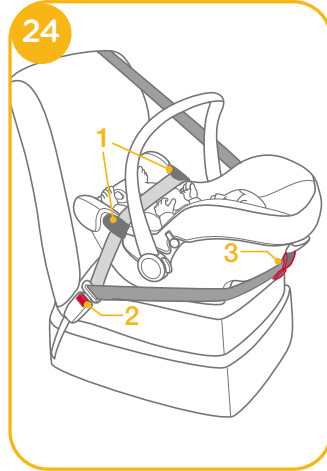
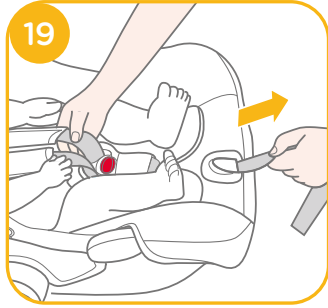
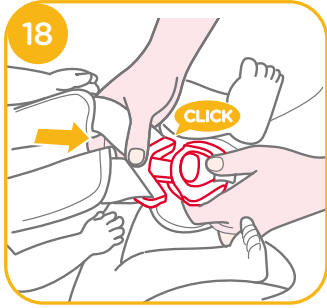

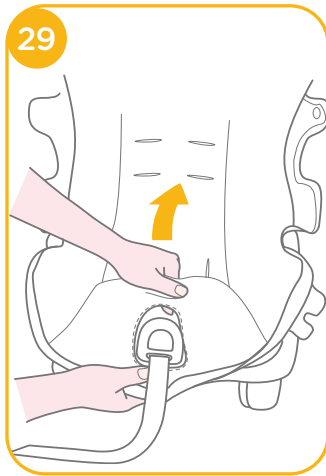
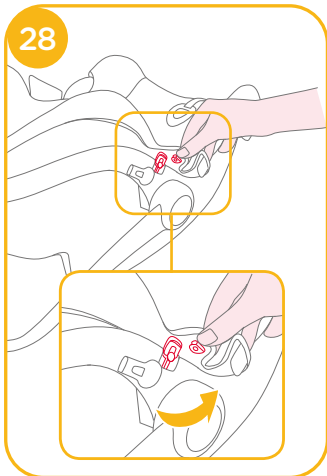

Note

## 警告

- ! 沒有任何嬰兒提籃可以保證100%遠離傷亡，然而正確的使用本嬰兒提籃可以降低寶寶傷亡的機率。
- ! 本嬰兒提籃適用於體重13公斤以下的寶寶。
- ! 任何束縛兒童保護裝置至車輛之織帶應束緊，任何束縛兒童之織帶應根據兒童身體進行調節，且此織帶不應扭曲。
- ! 請勿在未閱讀或了解本嬰兒提籃說明書及汽車說明書之前，使用或安裝本嬰兒提籃。
- ! 請勿擅自改造本兒童保護裝置，或使用其他廠商生產的零件來配合本兒童保護裝置使用。兒童保護裝置的性能會被影響，從而導致受傷或死亡。
- ! 本嬰兒提籃如有任何損壞或零件缺失時，請勿繼續使用。
- ! 請勿讓您的寶寶穿着過大的衣物，所穿的衣物必須能讓嬰兒提籃的安全帶適當而安全地扣在寶寶兩腿之間。
- ! 請勿將未使用汽車安全帶固定住的嬰兒提籃留在車內，以免緊急煞車時，傷害到其他乘客。若不經常使用嬰兒提籃時，請將其搬離汽車座椅。
- ! 請勿讓您的寶寶單獨留在嬰兒提籃內而無人照顧。
- ! 將您的寶寶放入嬰兒提籃後，必須正確的扣合及使用嬰兒提籃安全帶，並確保腰部織帶能有效束縛骨盆部位。
- ! 嚴禁將本嬰兒提籃裝置於設有正面空氣囊的座位上使用。
- ! 請勿使用二手嬰兒提籃或來歷不明的嬰兒提籃，因為它們可能存在危害寶寶安全的潛在危險。
- ! 不可使用繩子等其他物件代替汽車安全帶，以避免兒童被粗細繩索意外勒住。
- ! 請讓座椅遠離日光，以免產品溫度過高對兒童的皮膚造成傷害。
- ! 當本嬰兒提籃沒有座布時，請勿使用。

- ! 請勿使用非本製造商推薦的座布，否則會影響兒童安全座椅的總體性能。
- ! 任何行李或其他可能在碰撞中造成傷害之物品應適當牢固。
- ! 本兒童保護裝置僅能安裝到有固定靠背的汽車座椅上，不能安裝到靠背無法固定，以致靠背向前折疊或自由轉動的汽車座椅上。
- ! 請勿使用其他廠商的小座墊或底座來配合本嬰兒提籃使用。如需更換配件時，請與代理商聯繫。
- ! 請勿放置任何物品在兒童保護裝置下方。發生撞擊時，此物品會飛出，導致織帶變鬆，並影響其他乘客的安全。
- ! 本兒童保護裝置僅能在鋪滿墊子且沒有尖銳物品的汽車座椅上使用。
- ! 請勿讓汽車車門卡住嬰兒提籃的任何組件。
- ! 本兒童保護裝置若於意外中遭受劇烈撞擊後，不可繼續使用，應立即更換兒童保護裝置。意外可能導致兒童保護裝置產生潛在危險。
- ! 使用本產品前，請取掉PE袋和包裝材料，並放到嬰兒觸摸不到的地方。
- ! 長期不使用嬰兒提籃時，請將其搬離汽車座椅。
- ! 有關零件更換或維修問題，請向代理商查詢。
- ! 不管在哪種狀況下使用，把寶寶放入提籃後，請一直為寶寶繫好安全帶，以免寶寶從提籃內跌出。
- ! 手提嬰兒提籃前，請確認寶寶已繫好安全帶，且把手固定於直立段位。
- ! 請勿將嬰兒提籃置於桌子、椅子等高於地面的平台上。
- ! 不要使用非說明書中所述以及兒童保護裝置中所標示的承載觸點。

## 緊急情況處理

遇緊急事故時，需將安全帶剪斷，迅速將乘坐的嬰兒移離現場。

## 產品資訊



1. 這是“通用型”兒童保護裝置，符合安全標準 CNS 11497 及歐盟標準 ECE R44。作為通用兒童保護裝置，適合大多數，而不是全部的汽車座椅。
2. 如果汽車製造商在使用手冊中述明可以讓適用此年齡段的“通用型”兒童保護裝置配合的話，那麼更容易達到正確的匹配。
3. 此兒童保護裝置歸類為“通用型”，比其他無標示此注意事項的兒童保護裝置可適用於較多車輛。
4. 若有疑問，請洽兒童保護裝置代理商或撥 0800-001-256 / 02-25781188
5. 嬰兒提籃配合底座安裝的指示，請參考 i-Base 2(D1404) 說明書。

Allison Baby UK Ltd.

Venture Point, Towers Business Park,  
Rugeley, Staffordshire, WS15 1UZ  
www.joiebaby.com

產品名稱	汽車用兒童保護裝置
產品型號	CO911A, CO911AG
適用範圍	13公斤(約1.5歲)以下的寶寶
主要材質	塑膠、五金、布
適用群組	0+
淨重	4.0公斤
產品尺寸	670mmx440mmx565mm
製造日期	詳見產品上貼紙日期(年/月/日)
專利號碼	專利申請中
原產地	中國

委製商	巧兒宜國際股份有限公司
進口商	巧兒宜國際股份有限公司
地址	台北市內湖區瑞光路431號2樓
電話	02-27973000
統一編號	52603333

代理商	奇哥股份有限公司 Chickabiddy Co., Ltd
地址	台北市南京東路四段186號5樓
服務專線	0800-001-256/02-25781188
統一編號	04222671
網址	www.chick.com.tw



## 產品組件及各部位名稱

- |       |      |        |        |
|-------|------|--------|--------|
| 圖 1.1 | 座墊   | 圖 1.9  | 肩帶護片   |
| 圖 1.2 | 側面卡槽 | 圖 1.10 | 遮陽篷固定座 |
| 圖 1.3 | 小座墊  | 圖 1.11 | 遮陽篷    |
| 圖 1.4 | 調整織帶 | 圖 1.12 | 安全扣-插扣 |
| 圖 1.5 | 調整按鈕 | 圖 1.13 | 安全扣-母扣 |
| 圖 1.6 | 胯帶護片 | 圖 1.14 | 把手     |
| 圖 1.7 | 安全扣  | 圖 1.15 | 把手按鈕   |
| 圖 1.8 | 肩帶   | 圖 1.16 | 後向卡槽   |

請確認產品組件是否有遺漏，如有遺漏，請聯繫代理商。

## 安裝注意事項

- ! 請勿將此嬰兒提籃安裝在二點式安全帶的汽車座椅上，由於此種安全帶功能不完善，使用是非常危險的(圖2)(圖4.1)
- ! 此嬰兒提籃只適合安裝在設置有三點式安全帶的汽車座椅上(圖3)
- ! 請勿將此嬰兒提籃安裝在相對於汽車的行駛方向橫向或後向(圖4.1)或設有正面空氣囊(圖4.2)的汽車座椅上。
- ! 請勿將此嬰兒提籃安裝在前座上，防止意外發生時造成寶貴傷亡(圖4.3)
- ! 請勿將此嬰兒提籃安裝於可移動的汽車座椅上。

## 飛機上使用

- ! 當嬰兒提籃不配合底座使用時，可以將本產品安裝在二點式安全帶的飛機座椅上，請勿將此嬰兒提籃安裝在二點式安全帶的汽車座椅上。
- ! 請將嬰兒提籃後向安裝在飛機座椅上(圖30)
- ! 嬰兒提籃寬度為435mm，有些飛機座椅寬度為430mm，可以在嬰兒提籃下方增加填充物，方便嬰兒提籃的安裝。

## 調整把手

把手有3個段位可供調整(圖5)

- 1) 手提或置於汽車內時，請用段位1
  - 2) 當作嬰兒椅使用時，請用段位3
- 調整把手位置時，先按壓兩邊的把手按鈕(圖6.1)，將把手旋轉到適合段位後再鬆開把手按鈕(圖6.2)

## 肩帶正確位置

請依照寶貴的身高，選擇一對高度合適的肩帶孔。

- ! 肩帶須穿過最接近寶貴肩膀位置的肩帶孔(圖7)，肩帶位置太高是不正確的(圖8)
- ! 若肩帶位置不合適，意外發生時可能造成寶貴被拋出嬰兒提籃的危險。

## 調整肩帶高度

1. 按壓座椅前端的調整按鈕，並向外拉肩帶，以調鬆肩帶(圖9)
2. 將座椅背面的2條肩帶從T型鐵片上取下(圖10)
3. 拉出肩帶(圖11.1)，再將肩帶穿入高度合適的肩帶孔(圖11.2)
  - ! 肩帶先穿過肩帶護片(圖11.2)
  - ! 肩帶固定栓再穿過合適的肩帶孔。
  - ! 最後肩帶再穿過合適的肩帶孔。
4. 將T型鐵片重新穿入肩帶末端的織帶環中(圖12)
  - ! 肩帶必須先穿過肩帶固定栓，如圖12.1所示。
  - ! 肩帶須置於鐵管後方。
  - ! 安裝調整過程中，須注意肩帶不能扭曲。
  - ! 請小心組裝肩帶，組裝不正確的肩帶將無法保證寶寶的安全。

## 寶寶乘坐

### 提示

1. 小座墊的作用是為了保護寶寶，0-6個月的寶寶必須使用小座墊。
  2. 使用小座墊前，請裝上填充物(圖13)
  3. 將寶寶放入提籃後，請確認肩帶高度是否合適(圖7)
1. 按壓座椅前端的調整按鈕，並向外拉肩帶，以完全調鬆肩帶(圖14)
  2. 按壓紅色按鈕，鬆開安全扣(圖15)
  3. 依不同的使用需求，胯帶有2個段位可供調節
    - 較小的寶寶使用時，請使用第一段位(圖16.1)
    - 較大的寶寶使用時，請使用第二段位(圖16.2)
    - ! 建議大於10kg的寶寶須使用胯帶第二段位。

- 1) 調整胯帶位置時，拉出固定栓並放置水平(圖17.1&圖17.2&圖17.3)
  - 2) 旋轉固定栓，短邊朝前並從胯帶孔穿出(圖17.4)
  - 3) 從座墊前方將胯帶固定栓穿過最適合寶寶的胯帶孔(圖16)
4. 將寶寶放入座椅，並扣合安全扣(圖18)
  5. 向外拉調整織帶，調緊肩帶(圖19)
    - ! 請注意，寶寶與肩帶之間須有一個手掌的間距。

## 安裝嬰兒提籃

本嬰兒提籃可配合Joie某些底座使用。安裝方法取決於提籃是否配合底座使用。請參考適當章節安裝嬰兒提籃。

- ! 切勿把嬰兒提籃放置在裝有空氣囊的位置，以免造成危險(圖20)
- ! 在汽車內使用嬰兒提籃時，請將把手調到第1段位(圖5.1)
- ! 請將嬰兒提籃或底座朝向汽車尾部安裝。
- ! 請確保汽車安全帶沒有鬆弛或扭曲。
- ! 不管怎樣使用提籃，將寶寶置於提籃後，都須一直為寶寶佩戴好安全帶。

寶寶佩戴好安全帶後，請先選擇一個最合適的汽車後座，再安裝嬰兒提籃。

1. 將嬰兒提籃置於合適的汽車座椅上，拉出汽車安全帶後扣好汽車安全扣，再將汽車腰帶卡入嬰兒提籃兩邊的卡槽內(圖21)
  - ! 汽車安全帶母扣扣段若太長，汽車安全帶無法綁緊不能使用。(圖21.1)
2. 將汽車肩帶卡入嬰兒提籃後面的卡槽內(圖22)

3. 用力拉緊汽車安全帶，使汽車安全帶緊實的繫住嬰兒提籃(圖23)

! 盡力拉緊汽車安全帶，並確定汽車安全帶沒有鬆弛或扭曲。

! 汽車安全帶不能對寶寶的身體造成壓迫。

汽車安全帶安裝好後如圖24所示。

! 汽車腰帶卡入2個側面卡槽(圖24.1)

! 汽車安全扣正確扣合(圖24.2)

! 汽車肩帶卡入後方卡槽(圖24.3)

## 拆卸遮陽篷和座墊

拆卸遮陽篷時，按壓遮陽篷卡座內的凸點，同時拔出遮陽篷條即可(圖25)

拆卸座墊時，請參照以下操作步驟：

1. 請先移除小座墊。鬆開安全扣，解開小座墊兩側的鈕扣，即可取出小座墊。

2. 將胯帶從胯帶護片內的鬆緊帶中穿出，移除胯帶護片(圖26)

3. 請參考“肩帶高度調整”相關操作，移除肩帶和肩帶護片。

4. 將位於座椅邊緣背面的固定片拉出(圖27)

5. 將金屬鉤片從座椅邊緣取下，再將金屬鉤片往上拉，分離座墊和釋鎖按鈕(圖28)

6. 依圖29所示做法將座墊從調整按鈕周圍移除。

依相反步驟即可重新組裝座墊，但須確定肩帶沒有交叉或扭曲。

## 保養維護與保固

! 小座墊填充物拆除後，請將其存放於寶寶無法接觸到的地方。

! 請以30度以下水溫清洗。

! 請勿使用熨斗熨燙。

! 請勿使用漂白劑及乾洗。

! 請勿使用未經稀釋的中性清潔劑、汽油或其他有機溶劑清洗本兒童保護裝置，否則可能對保護裝置造成損壞。

! 請勿大力扭乾，過大力扭乾可能留下皺褶。

! 請於陰涼處鋪平晾乾。

! 當長時間不使用嬰兒提籃或底座時，請將嬰兒提籃或底座從汽車座椅上拆除，並存放於陰涼處及寶寶不易接觸的地方。



### 延長保固服務

請於購買起一個月內至奇哥官網進行登錄，登錄成功後即享有商品延長一年保固服務。

Joie™

0+ (0-13kg)

## gemm™ infant child restraint

### Instruction Manual

This product is approved to  
CNS 11497 and UN ECE  
regulation 44, 04 series  
of amendments.

Please read all the instructions  
in this manual before installing  
and using the product.

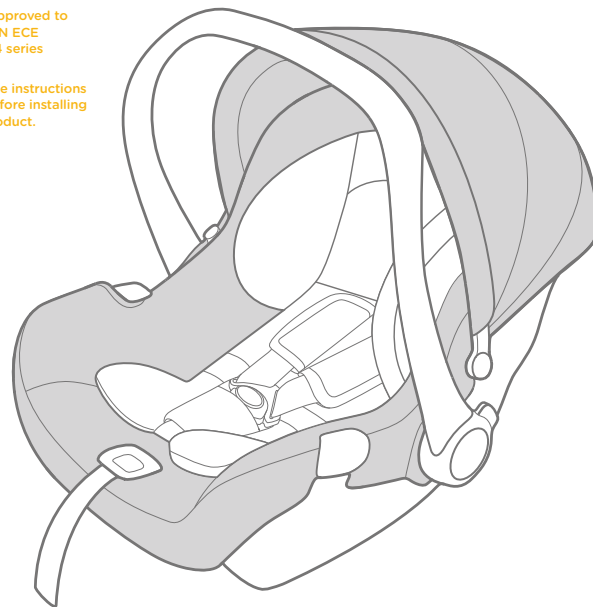

## Welcome to Joie

Congratulations on becoming part of the Joie family! We are so excited to be part of your journey with your little one. While traveling with the Joie GEMM™ infant child restraint you are using a high quality, fully certified safety Group 0+ infant child restraint. This product is suitable for use with children weighing under 13kg (approximately 1.5 years old or under). Please carefully read this manual and follow each step to ensure a comfortable ride and best protection for your child.

## Please Confirm

Make sure that your vehicle is equipped with 3-point retractable safety-belt. Seat belts may be different in design and length according to maker, manufacturing date, and type of the vehicle. This child restraint is only suitable for use in the listed vehicles fitted with 3-point retractor safety-belts, approved to CNS 3972 or UN ECE regulation 16 or other equivalent standards. This child restraint is approved to CNS 11497 and UN ECE regulation 44, 04 series of amendments.

## Infant child restraint

**! IMPORTANT: KEEP FOR FUTURE REFERENCE. PLEASE READ CAREFULLY.**

Keep this Instruction Manual always with the infant child restraint as below figure.

Please read all the instructions in this manual before installing and using the product.



## Contents

### Reference Figures

1 - 7

### English

WARNINGS	23
Emergency	25
Product Information	26
Parts List	27
Concerns on Installation	28
Aeroplane Installation	28
Handle Adjustment	29
Shoulder Harness Position	29
Shoulder Harness Height Adjustment	30
Securing Child in the Infant Child Restraint	31
Infant Child Restraint Installation	32
Detaching Canopy and Seat Pad	33
Care and Maintenance	34

# WARNINGS

- ! NO infant child restraint can guarantee full protection from injury in an accident. However, proper use of this infant child restraint will reduce the risk of serious injury or death to your child.
- ! This infant child restraint is designed ONLY for child weighing under 13kg.
- ! Any straps of infant child restraint and vehicle seat should be tightened and not twisted.
- ! DO NOT use or install this infant child restraint until you read and understand the instructions in this manual and in your vehicle owner's manual.
- ! DO NOT make any alterations or additions to any part of the infant child restraint or base. Do not use accessories or parts supplied by other manufacturers. The function of the infant child restraint could be altered, resulting in serious injury or death.
- ! DO NOT use this infant child restraint if it has damaged or missing parts.
- ! DO NOT have your child in unfitted clothes because this may prevent your child from being properly and securely fastened by the shoulder harnesses and the harnesses between thighs.
- ! DO NOT leave your infant child restraint or base unsecured in a car. Your infant child restraint or base must always be secured in the car.
- ! NEVER leave your child unattended with this infant child restraint.
- ! After your child is placed in this infant child restraint, the safety belt must be used correctly, and make sure the lap harnesses are right above the child's pelvis portion.
- ! NEVER install this infant child restraint on any vehicle seat equipped with safety airbags.
- ! Only use this infant child restraint on vehicle seats with seat backs that lock in place. Vehicle seats without latches, that fold forward or pivot freely should not be used.
- ! NEVER use a second-hand infant child restraint or an infant child restraint whose history you do not know because they may have structural damage that endangers your child's safety.
- ! NEVER use ropes or any other substitutes in place of vehicle belt in case of injuries from restraint.
- ! Please keep this infant child restraint away from sunlight, otherwise it may be too hot for the child's skin.
- ! The infant child restraint shall not be used without the soft goods.
- ! The soft goods should not be replaced with any besides the ones recommended by the manufacturer, because the soft goods constitute an integral part of the child restraint performance.
- ! DO NOT use another manufacturer's insert or base with this infant child restraint. See your distributor for Joie replacements ONLY.
- ! DO NOT put unsecured items in the vehicle because they can be thrown around and may injure occupants in a sharp turn, sudden stop, or collision.
- ! DO NOT put anything underneath your infant child restraint. In a crash it could fly out, making the webbing slack and creating a hazard for other passengers.
- ! Only use this infant child restraint on vehicle seats that are fully padded and are free of sharp objects.
- ! Make sure that no part of the child restraint become trapped by a movable seat or in a door of the vehicle.

# WARNINGS

- ! To avoid suffocation, remove plastic bag and packaging materials before using this product. The plastic bag and packaging materials should then be kept away from babies and children.
- ! DO NOT continue to use this infant child restraint or base after they have suffered any violent crash. Replace immediately as there may be invisible structural damage from the crash.
- ! Remove this infant child restraint from the vehicle seat when it is not in use for a long period of time.
- ! Consult the distributor for issues concerning maintenance, repair and part replacement.
- ! To avoid the risk of falling out, always secure the child using the safety harness when the child is placed in infant child restraint, even when the infant child restraint is not in the vehicle.
- ! Before carrying the infant child restraint by hand, ensure that the child is fastened with the safety harness, and that the handle is correctly locked in a vertical position.
- ! DO NOT use the infant child restraint on the tables, chairs or other elevated surfaces.
- ! DO NOT use any load bearing contact points other than those described in the instructions and marked in the child restraint.

# Emergency

In case of emergency or accidents, it is most important to have your child taken care of with first aids and medical treatment immediately.

# Product Information

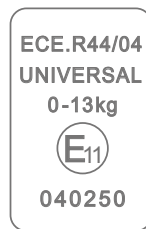

1. This infant child restraint is a 'Universal' child restraint. It is approved to CNS 11497 and UN ECE regulation 44, 04 series of amendments, for general use in vehicles and it will fit most, but not all, car seats.
2. A correct fit is likely if the vehicle manufacturer has declared in the vehicle handbook that the vehicle is capable of accepting a 'Universal' child restraint for this age group.
3. This infant child restraint has been classified as 'Universal' under more stringent conditions than those which applied to earlier designs which do not carry this notice.
4. If in doubt please consult the child restraint distributor or call 0800-001-256 / 02-2578118 directly.

## Allison Baby UK Ltd.

Venture Point, Towers Business Park,  
Rugeley, Staffordshire, WS15 1UZ  
www.joiebaby.com

<b>Product</b>	Infant Child Restraint
<b>Model</b>	C0911A, C0911AG
<b>Suitable for</b>	Child weighing under 13kg
<b>Materials</b>	Plastics, metal, fabrics
<b>Mass Group</b>	0+
<b>Net Weight</b>	4.0kg
<b>Product Size</b>	670mmx440mmx565mm
<b>Date</b>	Please see detailed date on label (year / month / day)
<b>Patent No.</b>	Patents pending
<b>Made in</b>	China

<b>Distributor</b>	Chickabiddy Co., Ltd
<b>Address</b>	5th FL, 186, Nanking E. Rd, Sec. 4, Taipei, Taiwan 10595
<b>Tel.</b>	0800-001-256 / 02-25781188
<b>Website</b>	www.chick.com.tw

## Parts List

Fig. 1.1	Seat Pad	Fig. 1.9	Shoulder Pad
Fig. 1.2	Side Guide	Fig. 1.10	Canopy Mount
Fig. 1.3	Insert	Fig. 1.11	Canopy
Fig. 1.4	Adjustment Webbing	Fig. 1.12	Harness Connectors
Fig. 1.5	Harness Adjustment Button	Fig. 1.13	Harness Buckle
Fig. 1.6	Crotch Pad	Fig. 1.14	Handle
Fig. 1.7	Safety Buckle	Fig. 1.15	Handle Button
Fig. 1.8	Shoulder Harness	Fig. 1.16	Rear Guide

The insert is different for different model, one model has only one insert.  
Make sure there are no missing parts, please contact the distributor if  
anything is missing.

## Concerns on Installation

- ! DO NOT install this infant child restraint on vehicle seats with Lap Belts. (Fig. 2) (Fig. 4.1)
- ! This infant child restraint is only suitable for vehicle seats with 3-Point Retractor Safety Belts. (Fig. 3)
- ! DO NOT install this infant child restraint on vehicle seats that face sideward or rearward with respect to the moving direction of the vehicle (Fig. 4.1) or the seat with airbag. (Fig. 4.2)
- ! DO NOT install this infant child restraint on the front vehicle seat in case injuries might happen to the child when there is an accident. (Fig. 4.3)
- ! This infant child restraint must be installed in the rearward facing mode. (Fig. 4.3)
- ! DO NOT install this infant child restraint on movable vehicle seats during installation.

## Aeroplane Installation

- ! The gemm can only be installed using a lap belt if being used in an aircraft without the base. Do not install in a vehicle using a lap belt.
- ! When being used in an aircraft, the infant child restraint must only be installed rear facing on the seat. (Fig. 30)
- ! Gemm infant child restraint width is 435mm, but some aircraft seat widths are 430mm. For narrow seat, please place padding under the seat to raise the height and allow it to fit between the arm rests.



## Handle Adjustment

The handle of the infant child restraint can be adjusted to 3 positions (Fig. 5)

Position 1 Position for car or hand transportation.

Position 3 Baby chair position.

To adjust the handle, squeeze handle buttons on both sides to release it (Fig. 6.1), and then rotate the handle until it clicks into any of the 3 positions. (Fig. 6.2)

## Shoulder Harness Position

Check that shoulder harnesses are set at the proper height. Please choose the proper pair of shoulder harness slots according to the child's height.

- ! Shoulder harnesses must go into the harness slots nearest to your baby's shoulders (Fig. 7), but not above the shoulder line. (Fig. 8)
- ! If the shoulder harnesses are not at proper height, the child might be thrown from the infant child restraint when there is an accident.

## Shoulder Harness Height Adjustment

1. Press the adjustment button at the front of the seat and pull the shoulder harnesses to loosen them. (Fig. 9)
2. At the back of the seat, take the harness ends off the metal junction plate. (Fig. 10)
3. Pull the harnesses through the slots in the seat (Fig. 11.1), insert them into the appropriate set of slots. (Fig. 11.2)
  - a. Thread the shoulder strap through shoulder harnesses. (Fig. 11.2)
  - b. Thread the shoulder harness anchor through the shoulder harness slot.
  - c. Thread the shoulder strap through the shoulder harness slot.
4. Reassemble the harness ends onto the junction plate. (Fig. 12)
  - ! Thread the shoulder strap through the shoulder harness anchor. (Fig. 12.1)
  - ! The shoulder harnesses must be placed in back of the two iron tubes.
  - ! During adjustment, make sure the shoulder harnesses are not twisted.
  - ! Use extreme care in threading the shoulder harnesses according to the figure. If the shoulder harnesses are not secure, they will not protect your baby properly.

## Securing Child in the Infant child restraint

### Note

1. Insert is for infant's protection. Infant insert must be used for children 0-6 months.
  2. Before using the insert, please assemble foam. (Fig. 13)
  3. After child is placed into the seat, check whether the shoulder harnesses are at proper height. (Fig. 7)
1. While pressing the adjustment button located at the front of the infant child restraint, pull completely the two shoulder harnesses of the infant child restraint. (Fig. 14)
  2. Unlock the buckle of the harnesses by pressing the red button. (Fig. 15)
  3. There are 2 positions crotch harness adjusted according to different requirements.  
Position 1 Smaller babies use this position (Fig. 16.1)  
Position 2 Larger babies use this position (Fig. 16.2)  
! Suggest heavier than 10kg babies use position 2.
    - i. Pull the crotch harness out and place it to be level. (Fig. 17.1&Fig. 17.2&Fig. 17.3)
    - ii. Rotate the crotch harness anchor to make the short side forwards, then thread it through the crotch harness slot. (Fig. 17.4)
    - iii. Rethread it through the slot that is closest to child's crotch from the front of the crotch harness. (Fig. 16)
  4. Place child into the infant child restraint and lock the buckle. (Fig. 18)
  5. Tension the shoulder harnesses by pulling adjustment webbing. (Fig. 19)  
! Make sure the space between the child and the shoulder harnesses is about the thickness of one hand.

## Infant Child Restraint Installation

The infant child restraint can be used with the joie base. The installation instructions vary depending on whether or not you are using the base. Please refer to the proper section.

- ! Do not place the infant child restraint on vehicle seat with airbag. Death or serious injury can occur. (Fig. 20)
  - ! When use the infant child restraint in a vehicle seat, please adjust the handle to position 1. (Fig. 5.1)
  - ! Face your infant child restraint or base toward the rear of the vehicle.
  - ! Ensure the vehicle safety belt is not slack or twisted.
  - ! Always fasten the harness of your infant child restraint securely on your infant, regardless of how it is being used.
- After fitting the harness to your child and determining which rear vehicle seat location is best, you are ready to install your infant child restraint.
1. Place the infant child restraint onto the vehicle seat where you wish to put it. Pull the vehicle safety belt out and lock it into the vehicle buckle, sliding the vehicle lap belt into the side guides of the infant child restraint. (Fig. 21)  
! The infant child restraint can not be used if the vehicle safety belt with female buckle is too long to tie the infant child restraint. (Fig. 21.1)
  2. Slide diagonal belt into the rear guide. (Fig. 22)
  3. Pull the belt to fasten the infant child restraint tightly and securely. (Fig. 23)  
! Tension the vehicle safety belt as much as possible, check that it is not loose or twisted.

- ! The vehicle safety belt shall not cause pressure on any part of the child.

Correctly assembled vehicle safety belt is shown as Fig. 24

- ! Lap belt must pass through the two side guides, as Fig. 24.1
- ! The vehicle buckle is locked correctly, as Fig. 24.2
- ! Diagonal belt must pass through the rear guide, as Fig. 24.3

## Detaching Canopy and Seat Pad

To detach the canopy, while pressing the button in the canopy mount, pull the canopy bow out. (Fig. 25)

To detach the seat pad, you should refer to the following steps:

1. You must remove the insert first. To do this simply unlock the buckle, then unclip the snaps on both sides of the insert and pull out away from the seat.
2. To remove the crotch pad, first locate the elastic on the inside of the crotch pad. Pull both the elastic and the crotch pad over the buckle to remove. (Fig. 26)
3. You must remove the shoulder harnesses and shoulder pads. To do this please refer to the section 'Shoulder Harness Strap Height Adjustment'.
4. Pull out the fastening pieces underneath the edge of the seat. (Fig. 27)

5. Detach the metal hook from the edge of the infant child restraint, and then lift it up to separate the seat pad from the release button. (Fig. 28)

6. Detach the seat pad from around the adjustment button as shown in (Fig. 29)

To refit the seat pad simply reverse the steps above, however make sure that the shoulder harnesses are not crossed over and not twisted.

## Care and Maintenance

- ! After removing the foam of insert please store it somewhere that the child can not access it.
- ! Please wash the soft goods with cold water under 30°C.
- ! Do not iron the soft goods.
- ! Do not bleach or dry clean the soft goods.
- ! Do not use undiluted neutral detergent gasoline or other organic solvent to wash the infant child restraint or base. It may cause damage to the infant child restraint.
- ! Do not twist the soft goods to dry with great force. It may leave the soft goods with wrinkles.
- ! Please hang dry the soft goods in the shade.
- ! Please remove the infant child restraint and base from the vehicle seat if not in use for a long period of time. Put the infant child restraint in a cool, dry place and somewhere your child can not access it.

## Note



Joie™

bring the kids™

Share the joy at [joiebaby.com](http://joiebaby.com)

IM-000584M