

Joie™

3.5 - 15 kg

savvy™

多功能揹帶

使用說明書

本產品符合安全標準 CNS 16006-2:2017
及歐洲安全標準 EN 13209-2:2015測試和認證
組裝及使用本產品前
請先閱讀說明書全文

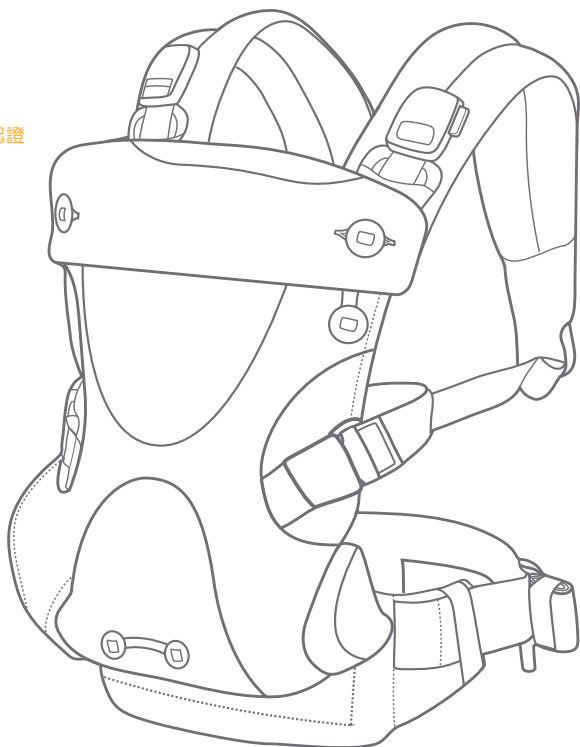

重要，保留以備參照：請詳細閱讀

使用產品前請仔細閱讀本說明書，
並妥善保存說明書以便日後參考。

<p>1 臉朝內正向式/嬰兒模式 3.5-6.5公斤，最小年齡0個月，最大體重6.5公斤</p> 	<p>臉朝內正向式 6.5-14公斤，最小年齡4個月，最大體重14公斤</p> 
<p>臉朝外正向式 9-14公斤，最小年齡6個月，最大體重14公斤</p> 	<p>後揹式 11-15公斤，最小年齡9個月，最大體重15公斤</p> 

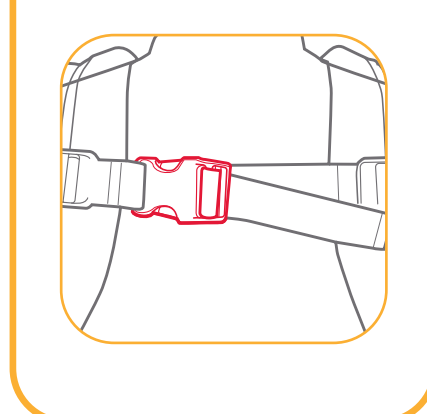
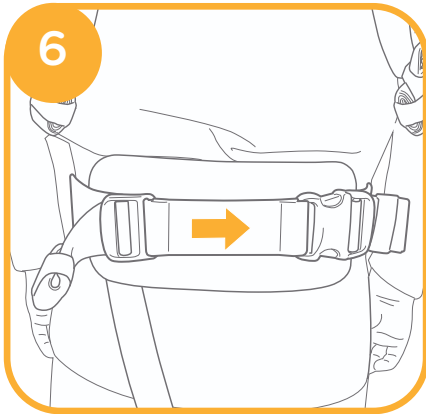
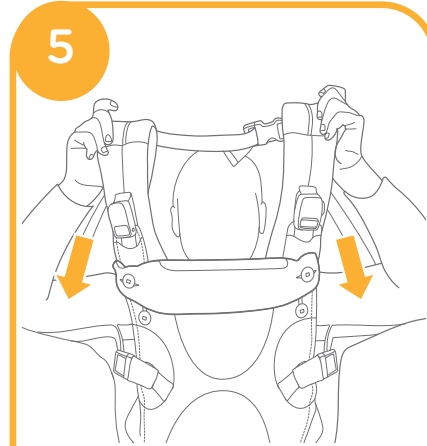
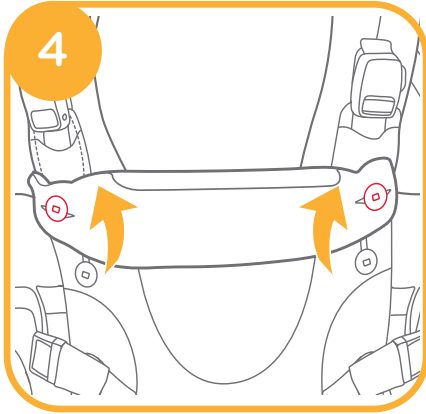

臉朝內正向式/嬰兒模式(需使用新生兒高度墊)

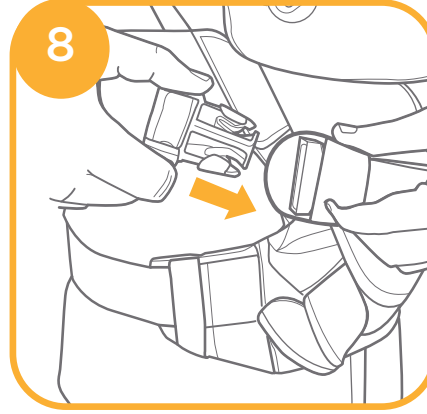
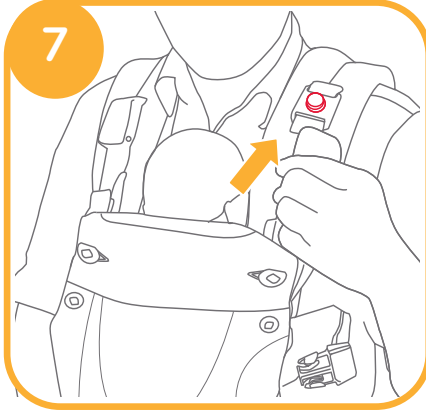
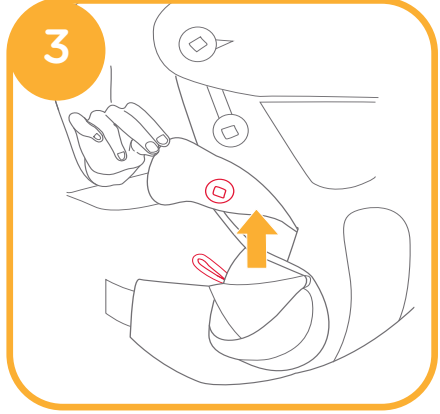
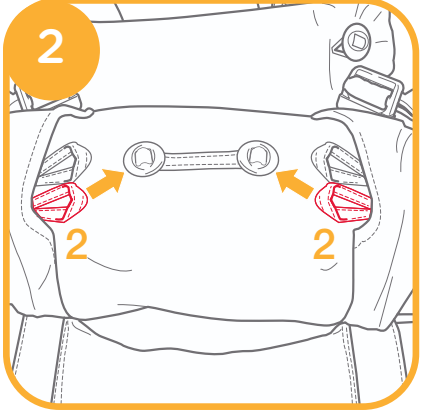

臉朝內正向式

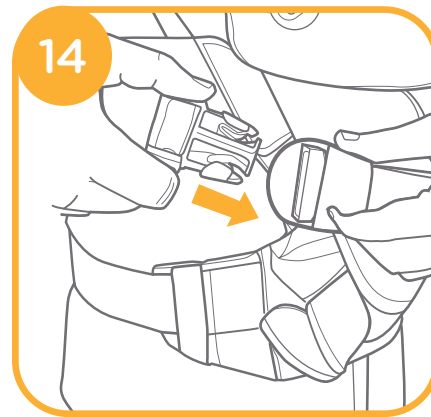
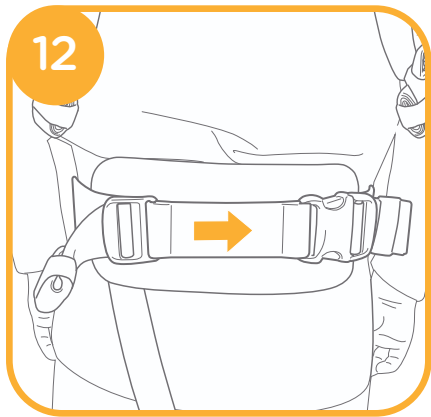
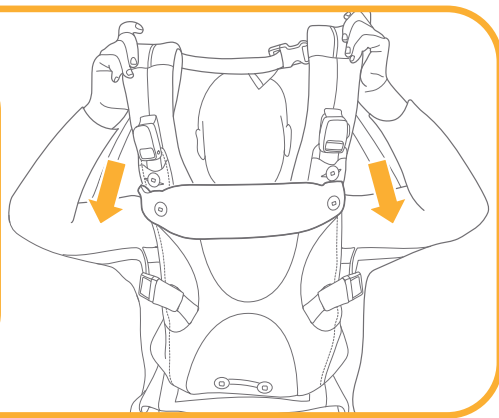
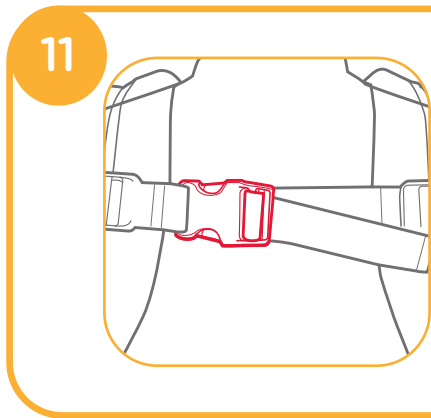
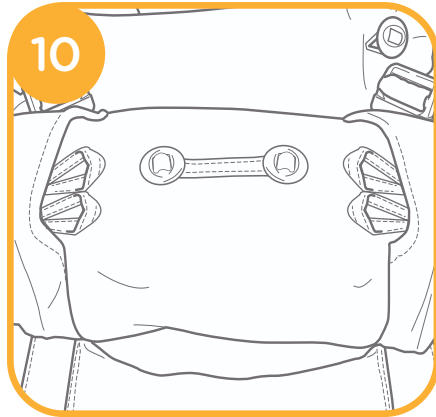
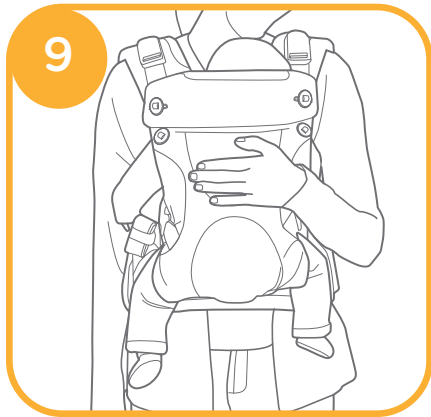

臉朝外正向式

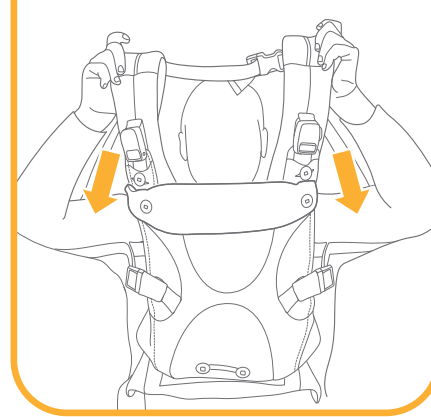
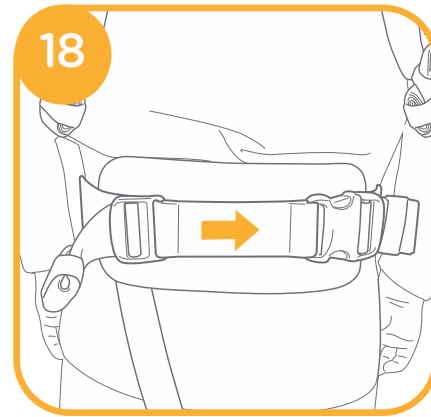
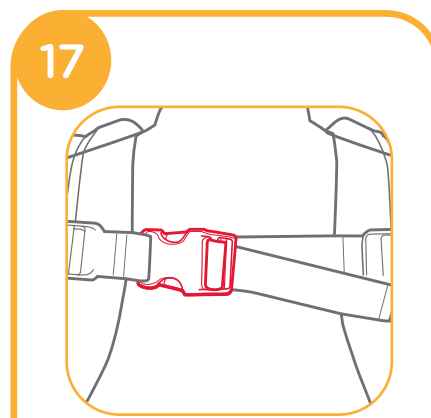
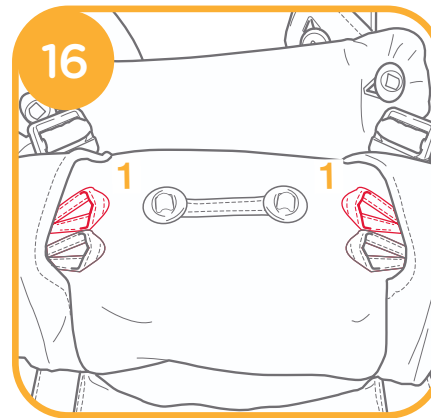

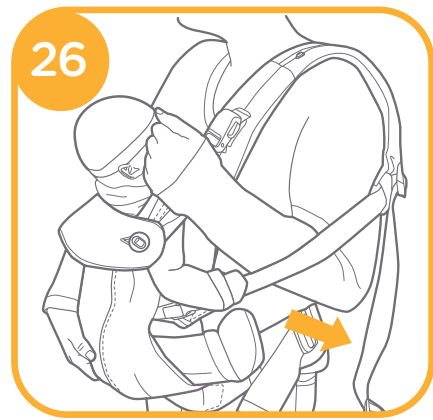
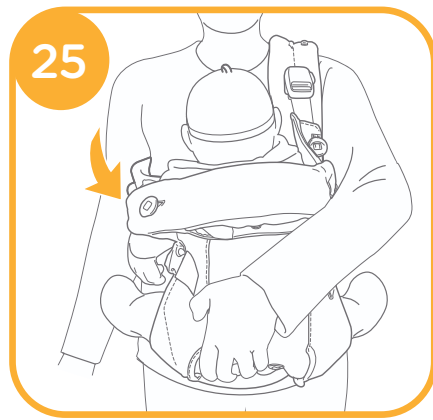
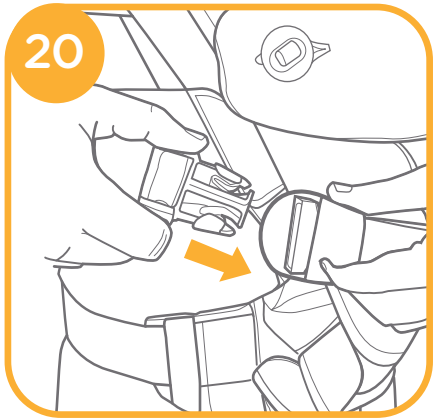
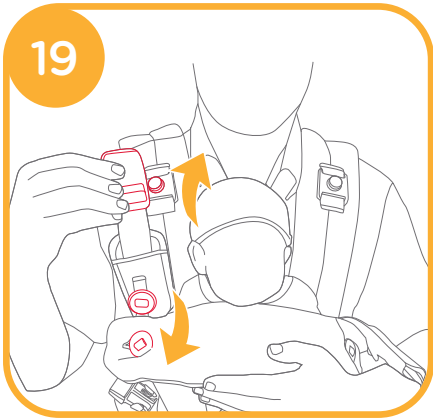

"M" 字型

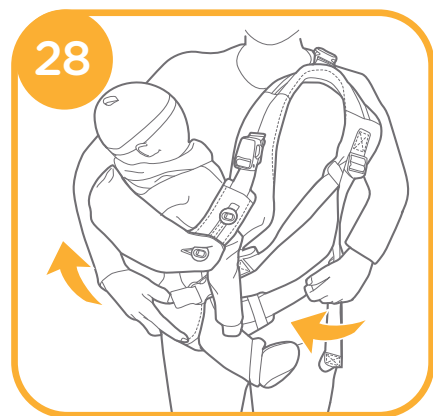
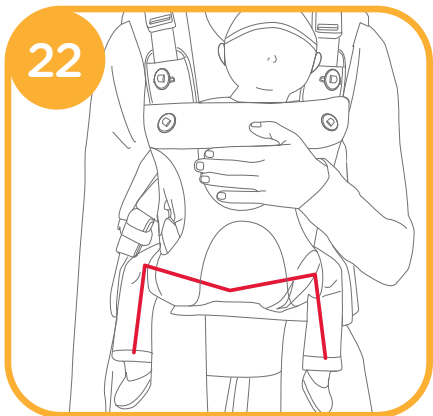

後措式

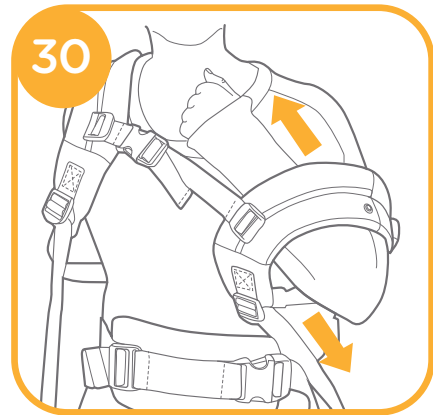
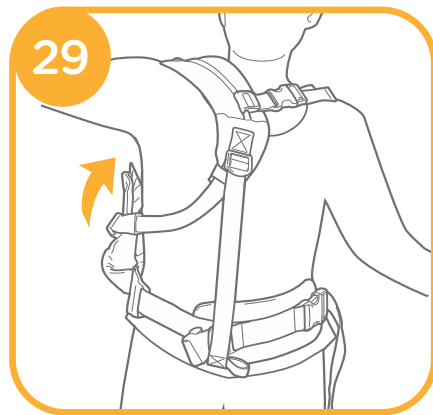

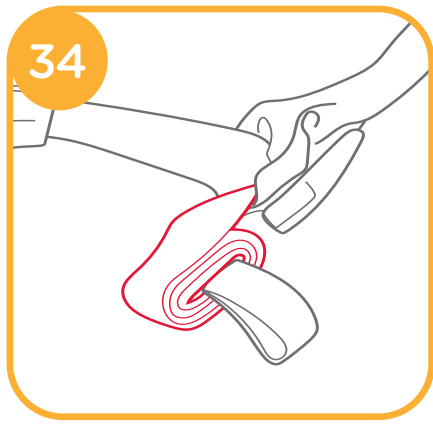
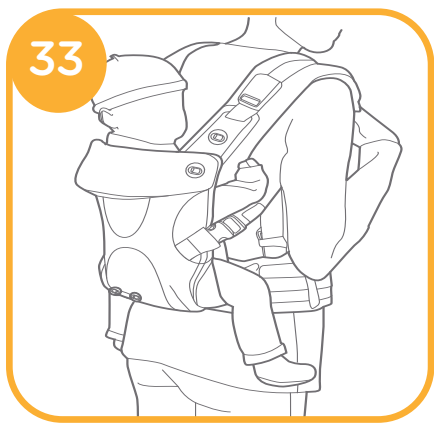
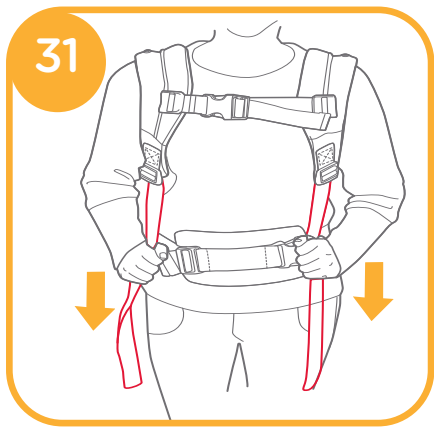

遮光罩

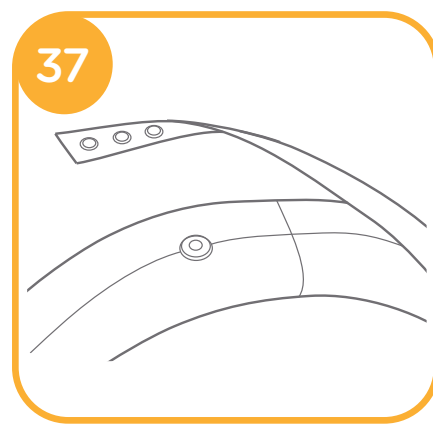
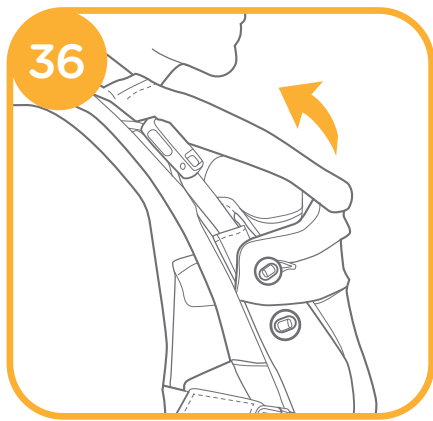
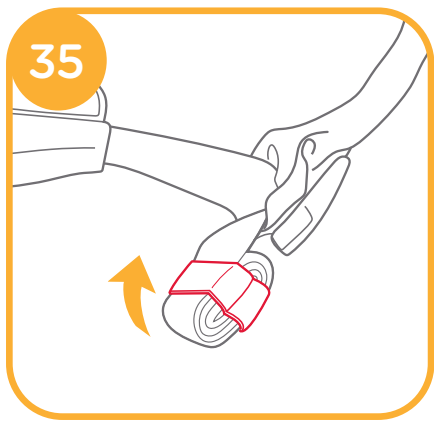

防風罩

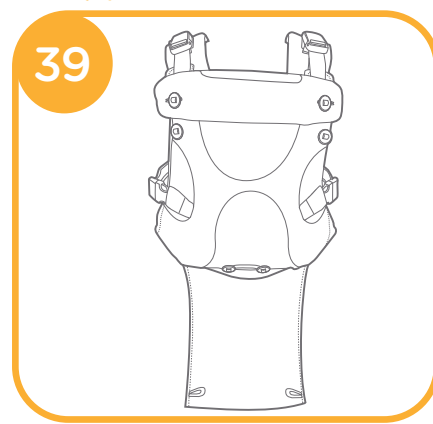
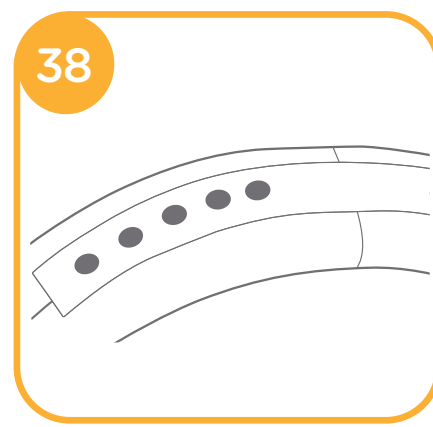

安撫口水墊

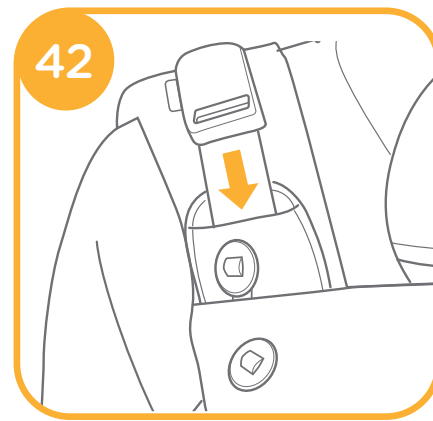
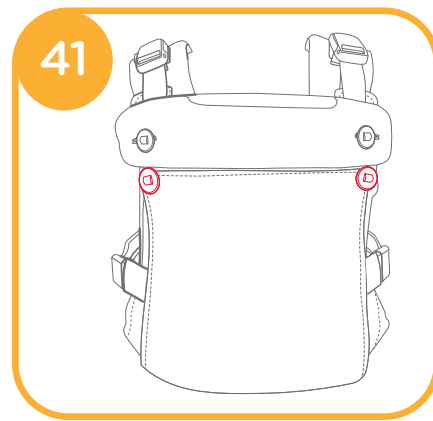

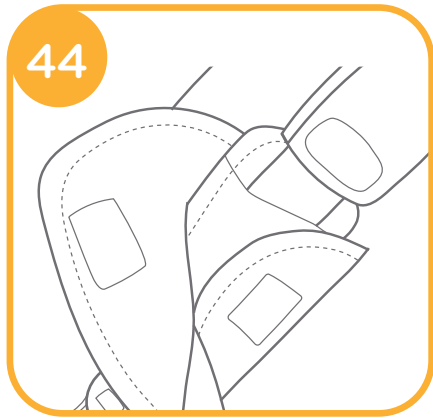
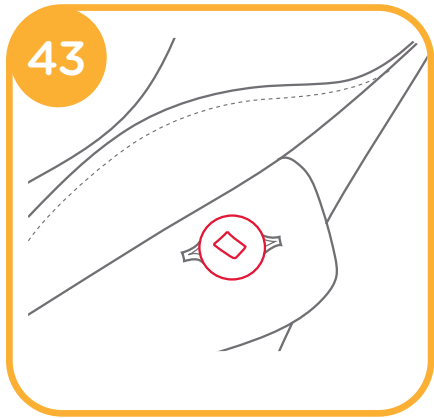

肩帶口水墊

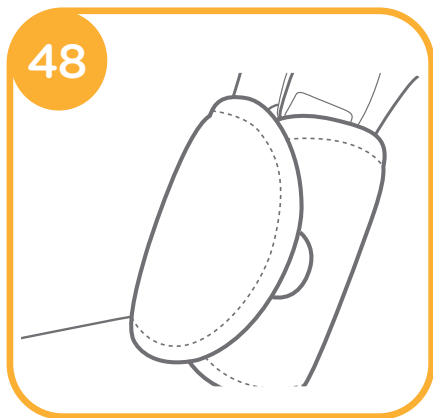
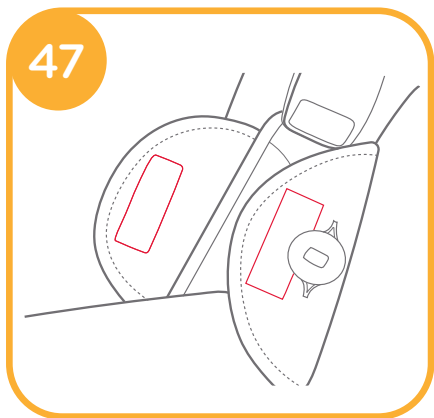
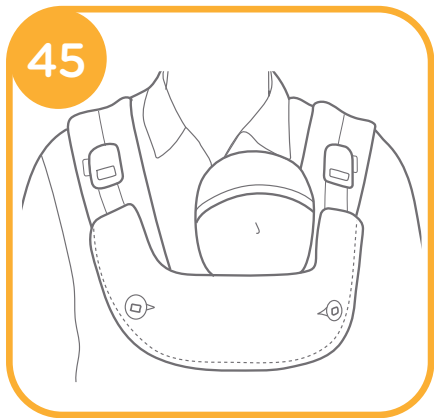

NOTE

CH 謝謝您使用本產品

您剛買了一台通過安全標準CNS 16006-2:2017 和歐洲安全標準EN 13209-2:2015 檢測的多功能揹帶，這條多功能揹帶適用於體重15kg 以下的寶寶。

請仔細閱讀本說明書並依照指示操作，這樣才能保障並提供您的寶寶一個安全又舒適的使用環境。

本說明書中採用的插圖是為了說明產品的操作方法和產品結構，當插圖與實物存在差異時，請以實物為準。

目錄

參照圖示	1-9
目錄	11
緊急情況處理	12
產品資訊	13
產品組件及各部件名稱	14
警告	15

產品使用	17
臉朝內正向式/嬰兒模式	17
腿部空間調整方式	17
臉朝內正向式	17
臉朝外正向式	18
後揹式	18
使用配件	19
遮光罩	19
防風罩	19
安撫口水墊	20
肩帶口水墊	20
保養維護與保固	20
English	21

緊急情況處理

遇緊急事件或事故時，需迅速急救或送醫治療照顧您的寶寶是非常重要的。

產品資訊

Allison Baby UK Ltd.

Venture Point, Towers Business Park,
Rugeley, Staffordshire, WS15 1UZ
www.joiebaby.com

產品名稱 Savvy多功能揹帶
產品型號 V1907
用途 需要手抱或揹負嬰兒時所設計的一人用嬰幼兒揹帶

適用範圍
(最小年齡及最大體重)

- 1 - 臉朝內正向式/嬰兒模式
3.5-6.5公斤, 最小年齡0個月, 最大體重6.5公斤
- 2 - 臉朝內正向式
6.5-14公斤, 最小年齡4個月, 最大體重14公斤
- 3 - 臉朝外正向式
9-14公斤, 最小年齡6個月, 最大體重14公斤
- 4 - 後揹式
11-15公斤, 最小年齡9個月, 最大體重15公斤

安全標準 CNS 16006-2:2017
EN 13209-2:2015

主要材質 塑膠(PA, POM)、布(聚酯纖維, 棉, 聚氨酯, EVA)、五金(不銹鋼, 磁鐵)

淨重 0.97 kg
製造日期 詳見產品上貼紙日期(年/月/日)
原產地 中國
委製商 巧兒宜國際股份有限公司
進口商 巧兒宜國際股份有限公司
地址 台北市內湖區瑞光路431號2樓
電話 02-27973000
統一編號 52603333

代理商 奇哥股份有限公司 Chickabiddy Co., Ltd
地址 台北市南京東路四段186號5樓
服務專線 0800-001-256 / 02-25781188
統一編號 04222671
網址 www.chick.com.tw

使用本產品前請先閱讀說明書全文, 如果您對於使用本產品還有任何疑問, 請撥服務專線0800-001-256 / 02-25781188

產品組件及各部件名稱

組裝前請確認所有部件已經齊全, 如有遺漏, 請與銷售商聯繫。本產品無需工具進行組裝。

- | | |
|-------------|--------------|
| 1 肩帶磁扣 | 9 調整扣 |
| 2 新生兒頸椎保護墊 | 10 遮光罩收納袋 |
| 3 頸椎保護墊固定鈕扣 | 11 遮光罩扣 |
| 4 腿部空間調整扣 | 12 肩帶固定扣 |
| 5 側帶固定扣 | 13 腰帶固定扣 |
| 6 胯部空間調整繩 | 14 安撫口水墊(X2) |
| 7 新生兒高度調整繩 | 15 肩帶口水墊(X2) |
| 8 防風罩收納袋 | |

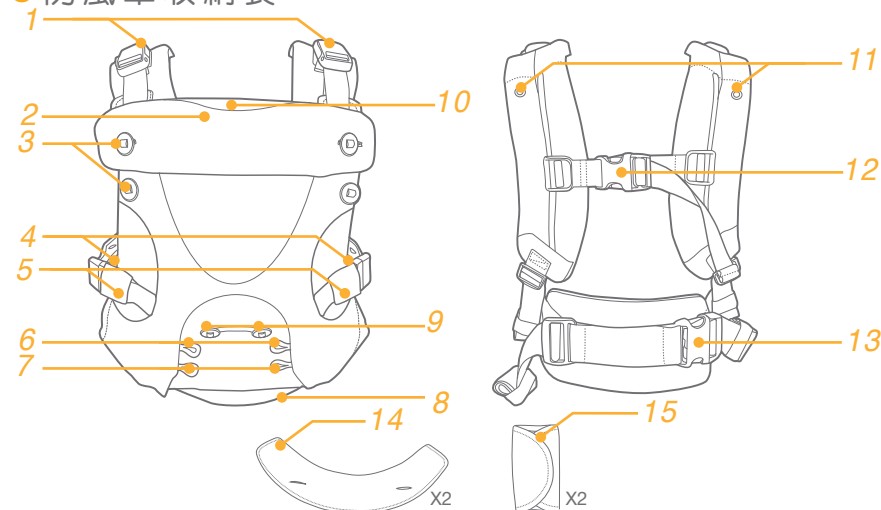



警告

跌落及窒息危險

跌落危險 - 嬰兒可能從腿部開口處跌落，請按照指示使用。

- 嬰幼兒可能從腿部開口處滑落，請確認腿部開口調整扣已調至合適大小。
- 使用揹帶前，請確認所有扣具已扣緊、所有調整織帶已固定。
- 嬰幼兒以及照護者之移動，可能對照護者之平衡產生不利影響。
- 照護者彎腰或前傾時須特別小心。
- 揹帶適用於休閒活動，運動時不得使用。
- 此揹帶只適用於體重3.5公斤至15公斤的嬰兒。

窒息危險 - 4個月以下的嬰兒在此款揹帶中若臉部緊貼大人身體會引致窒息。

- 切勿將嬰兒過緊地束縛在大人身上。
- 為嬰兒頭部活動留下足夠空間。
- 確保嬰兒臉部任何時候都不會被遮蓋。

⚠ 其他注意事項

- ! 使用前請檢查所有扣具、調整揹帶、鈕扣及拉鏈皆是安全的。
- ! 使用前請檢查是否有磨損、撕裂或扣具毀壞的跡象。
- ! 若零件遺失或損壞，停止使用揹帶。
- ! 嬰兒頭部還不能直立豎起前，嬰兒臉部須朝向大人。
- ! 請確保嬰兒妥善地置於揹帶內，包括雙腿位置。
- ! 請確保嬰兒的雙腿在使用揹帶時按照說明分開坐好，雙臂從手臂孔位穿出。
- ! 使用揹帶時，需時刻注意嬰兒手臂、腿部及腳部不被揹帶束縛。後揹式揹法時請加倍注意。
- ! 預防跌落危險，請確保嬰兒於揹帶內的姿勢是正確的。
- ! 揹帶穿戴完成前請全程用手承托嬰兒。

- ! 嬰兒模式僅適用於承載3.5公斤至6.5公斤的嬰兒且嬰兒需要面對大人。
- ! 早產兒、呼吸有困難及少於四個月的嬰兒最容易引起窒息。
- ! 對於出生體重低的嬰兒及進行醫療的嬰幼兒，建議使用本產品之前，先諮詢醫療專業人員之意見。
- ! 使用揹帶時務必隨時注意嬰幼兒。
- ! 注意居家環境之危害，例：熱源、熱飲濺出。
- ! 謹防熱飲噴濺至揹帶中的嬰兒。
- ! 嬰幼兒以及照護者之移動，可能對照護者之平衡產生不利影響。
- ! 此揹帶僅可由健康成人於行走、站立或坐立時使用。
- ! 揹帶適用於休閒活動，運動時不得使用。
- ! 配戴心律調整器大人請勿使用此揹帶。揹帶上的磁扣會與您的心律調整器產生干擾。
- ! 運動、困倦或身體狀況影響平衡時請勿使用此揹帶。
- ! 進行會接觸熱源或化學品的活動例如烹飪或清潔時，請勿使用此揹帶。
- ! 駕駛或乘坐機動車輛時請勿使用此揹帶。
- ! 嬰兒在揹帶中時請勿躺下或睡眠。

產品使用

見圖①

請依照下方說明，正確使用產品，以確保孩童安全。共有四種模式，3.5公斤以下的新生兒不適用 ①

臉朝內正向式/嬰兒模式 (含內建新生兒坐墊)

見圖② - ⑨

！須將嬰兒置於靠近您且高度相近處，並確保隨時都可以清楚看到您孩子的臉。體重介於3.5-6.5公斤的嬰兒，請務必使用新生兒頸椎保護墊。保護墊在嬰兒的頸部可以直立撐起頭部時(約4個月)，才可以往下折。

1. 將新生兒高度調整繩扣上調整扣 ②
2. 將腿部空間調整扣扣上，使腿部開口減小成更合適您孩子的空間大小 ③
3. 將頸椎保護墊往上立起，扣在兩側上排的頸椎保護墊固定鈕扣上 ④
4. 確認肩帶固定扣已扣上，並將頭部穿過開口，肩帶固定扣應位於兩側肩胛骨中間 ⑤
5. 將腰帶環繞於腰部後方，扣上腰帶固定扣使其緊貼腰部 ⑥
6. 將嬰兒放至揹帶中，用一手扶着孩子，用另一隻手將肩帶磁扣依序扣上，一次扣一個 ⑦
7. 將側帶固定扣扣上，並調整至適當長度 ⑧
8. 完成以上步驟，臉朝內正向式/嬰兒模式 (含內建新生兒坐墊) 即可使用 ⑨

腿部空間調整方式

見圖③

1. 當您的孩子少於6.5公斤時，請務必使用腿部空間調整扣使腿部開口減小成更適合您孩子的大小 ③

臉朝內正向式

見圖⑩ - ⑮

1. 使用此模式時不需使用任何調整扣 ⑩。將腿部空間調整扣解開，使腿部開口放大成更合適您孩子的空間大小 ③
2. 確認肩帶固定扣已扣上，並將頭部穿過開口，肩帶固定扣應位於兩側肩胛骨中間 ⑪
3. 扣上腰部調整釦，並調整緊貼腰部 ⑫
4. 將嬰兒放至揹帶中，用一手扶着孩子，用另一隻手將肩帶磁扣依序扣上，一次扣一個 ⑬
5. 將側帶固定扣扣上，並調整至適當長度 ⑭
6. 完成以上步驟，臉朝內正向式即可使用 ⑮

臉朝外正向式

見圖⑯ - ⑳

1. 將胯部空間調整繩扣上調整扣 ⑯
2. 確認肩帶固定扣已扣上，並將頭部穿過開口，肩帶固定扣應位於兩側肩胛骨中間 ⑰
3. 扣上腰部調整釦，並調整緊貼腰部 ⑱
4. 將嬰兒放至揹帶中，用一手扶着孩子，用另一隻手將肩帶磁扣依序扣上，一次扣一個 ⑲
5. 將側帶固定扣扣上，並調整至適當長度 ⑳
6. 完成以上步驟，臉朝外正向式即可使用。請確認嬰兒維持雙腿自然的彎曲姿勢以保護髖關節及膝關節，符合人體工學的M型腿姿勢可減少髖關節所受到的壓力 ㉑ ㉒
7. 將腿部空間調整扣解開，使腿部開口放大成更合適您孩子的空間大小 ③

Savvy榮獲國際髖關節發育不良協會(IHDI)認證，揹寶寶時能維持正確姿勢，有效的保護寶寶髖關節。

後揹式

見圖㉓ - ㉕

- ！建議您在實際使用前，先多次練習至熟練。
- ！使用後揹式時，切勿使孩子面朝外。

1. 以臉朝內正向式將您的孩子安置好，放鬆肩帶長度 23 24
2. 左手抱着孩子，右手從右肩帶上方穿出 25
3. 換右手抱着孩子，左手從左肩帶調整織帶下方穿出 26
4. 右手抱好孩子，左手輔助將孩子往右邊轉至右邊腰側 27
5. 右手抱好孩子，左手將腰帶及肩帶轉至後方 28
6. 用左手將孩童固定至後方，右手向上穿進右邊肩帶 29
7. 用右手固定孩子，左手向上穿進左邊肩帶 30
8. 慢慢將肩帶調整織帶下拉，將長度調整至適當的位置 31
9. 上下左右移動調整肩帶固定扣至適當位置 32
10. 請確認您的孩子在揹帶裡是舒適的，檢查所有的扣具皆扣好。為孩子的頭部活動留下足夠空間並確保孩子臉部在任何時候都不會被遮蓋。完成上述步驟後，即可使用後揹式 33
11. 避免造成困擾，可將過長的肩帶調整織帶捲起，並用織帶尾端的彈力繩固定 34 35
12. 將腿部空間調整扣解開，使腿部開口放大成更合適您孩子的空間大小 3

使用配件

遮光罩

見圖 36 - 38

！請確認遮光罩沒有遮蔽住您孩子的口鼻，也沒有過緊而壓迫到孩子的頭部。

1. 請先確認新生兒頸椎保護墊是往上立起並扣在上排的保護墊扣上，然後將遮光罩從頸椎保護墊頂端口袋中拉出 36
2. 將單邊遮光罩帶上鈕釦對扣於肩帶上的鈕扣，另外一邊亦同 37
3. 依照最適合您孩子的鬆緊度，將遮光罩扣到肩帶上最適合的扣子 38

防風罩

見圖 39 - 41

1. 將防風罩自揹帶底部防風罩收納袋中拉出 39
2. 將防風罩扣至頸椎保護墊上。較小的嬰兒請扣上上方兩顆扣子 40；較大的嬰兒請扣上下方兩顆扣子 41

安撫口水墊

見圖 42 - 45

1. 請先確認新生兒頸椎保護墊是往下折並扣在下排的保護墊扣上，並將過長的肩帶磁扣調整織帶收進磁扣下方的小口袋內 42
2. 將安撫口水墊攤開鋪在新生兒頸椎保護墊上，將口水墊扣於下排保護墊扣上 43
3. 將安撫口水墊左右兩端的布料環繞肩帶調整織帶。口水墊應只包覆肩帶調整織帶並介於調整織帶與肩帶之間 44 45

肩帶口水墊

見圖 46 - 48

1. 請先確認新生兒頸椎保護墊是往下折並扣在下排的保護墊扣上，並將過長的肩帶磁扣調整織帶收進磁扣下方的小口袋內 46
2. 將肩帶口水墊的鈕扣孔扣在上排的保護墊扣上，用黏扣帶固定 47 48

保養維護與保固

！請參考揹帶上洗滌標版內容的洗滌及乾燥方式。

！建議使用洗衣網進行洗滌。

！長期使用之後，在正常狀況下，布料可能產生褪色、磨損或撕裂。

！為確保安全，請使用Joie原廠零配件。

！請定期檢查您的揹帶功能是否正常與零件是否鬆弛磨損或脫落。一旦發生以上任何狀況，請立即停止使用此揹帶。

！當長時間不使用揹帶時，請將其存放於陰涼處及寶寶不易接觸的地方。

延長保固服務

請於購買起一個月內至奇哥官網進行登錄，登錄成功後即享有商品延長一年保固服務。



Congratulations on becoming part of the Joie family! We are so excited to be part of your life with your little one. While using the Joie Savvy™, your baby is enjoying a high quality, fully certified carrier, approved to CNS 16006-2:2017 and European safety standards EN 13209-2:2015. Please carefully read this manual and follow each step to ensure a comfortable carrying and best protection for your child.

Please keep the Instruction Manual handy for future reference.

Visit us at Joiebaby.com to download manuals and see more exciting Joie products.

IMPORTANT! READ CAREFULLY AND KEEP FOR FUTURE REFERENCE.

Contents

Figures	1-9
Contents	21
Emergency	21
Product Information	22
Parts List	22
WARNING	23
Use Modes and Requirements	24
Newborn Mode with Integrated Newborn Seat	24
Adjust the leg opening	24
Infant Facing-In Mode	24
Infant Facing-Out Mode	25
Back Carry Mode	25
Privacy Shield and Sun Protection	25
All-Season Shield	26
Bib	26
Harness Covers	26
Care and Maintenance	26

Product Information

Read all the instructions in this manual before using this product. If you have any further questions, please consult the retailer. Some features may vary depending on model.

Product	Savvy Carrier
Suitable for	3.5kg to 15kg
Materials	Plastics, metal, fabrics
Patent No.	Patents pending
Made in	China

Parts List

Read all the instructions in this manual before using this product. If you have any further questions, please consult the retailer. Some features may vary depending on model. No tools are required for assembly.

- | | |
|----------------------------------|---|
| 1 Magnetic Shoulder Buckles | 9 Adjustment Buttons |
| 2 Head Support | 10 Privacy Shield and Sun Protection Pocket |
| 3 Head Support Buttons | 11 Privacy Shield and Sun Protection Snaps |
| 4 Leg Opening Adjustment Buttons | 12 Shoulder Strap Adjustment Buckle |
| 5 Side (Leg) Buckles | 13 Lumbar Support Buckle |
| 6 Adjustment Button Hooks 1 | 14 Bib (X2) |
| 7 Adjustment Button Hooks 2 | 15 Harness Covers (X2) |
| 8 All-Season Shield Pocket | |

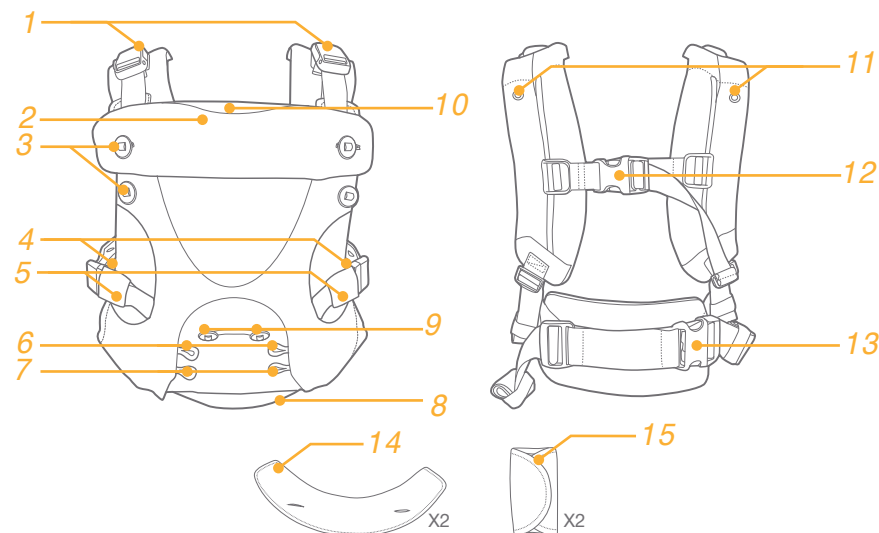

Emergency

In case of emergency or accident, it is most important to have your child taken care of with first aid and medical treatment immediately.

WARNING

- ! Check to assure all buckles, snaps, straps, and adjustments are secure before each use.
- ! Check for ripped seams, torn straps or fabric and damaged fasteners before each use.
- ! Stop using the carrier if parts are missing or damaged.
- ! Child must face towards you until he or she can hold head upright.
- ! Ensure proper placement of child in product including leg placement.
- ! Make sure baby's legs are straddling the seat and arms extend through arm holes.
- ! Regularly check that your child is comfortably and securely seated in the baby carrier, especially when using as a back carrier.
- ! To prevent hazards from falling, ensure that your child is securely positioned in the carrier.
- ! Hold your baby closely at all times until correctly attached.
- ! Premature infants, infants with respiratory problems, and infants under 4 months are at greatest risk of suffocation.
- ! For low birth weight babies and children with medical conditions, seek advice from a health professional before using the product.
- ! When using the soft carrier, monitor your child.
- ! Be aware of hazards in the domestic environment e.g. heat sources, spilling of hot drinks.
- ! Take care when bending or leaning forward or sideways.
- ! Your balance may be adversely affected by your movement and that of your child.
- ! This baby carrier is designed for use by adults while walking, standing or sitting only.
- ! This baby carrier is not suitable for use during sporting activities.
- ! DO NOT use this soft carrier if you use a pacemaker, as the magnetic buckles can interfere with the pacemaker.
- ! NEVER use a soft carrier when balance or mobility is impaired because of exercise, drowsiness, or medical conditions.
- ! NEVER use a soft carrier while engaging in activities such as cooking and cleaning which involve a heat source or exposure to chemicals.
- ! NEVER wear a soft carrier while driving or being a passenger in a motor vehicle.
- ! NEVER lie down or sleep with baby in the baby carrier.

Use Modes and Requirements

see image 1

Please refer to the wording below for proper usage of each product mode to ensure the safety of your child. There are four carry modes. DO NOT use carrier for newborns under 3.5 kg. 1

Newborn Mode with Integrated Newborn Seat

see images 2 - 9

- ! Child should be positioned close to you and high on your body. Keep your child's face visible to you at all times. Use head support for children weighing 3.5 - 6.5 kg. Your baby's head should be supported until he or she has a strong head control (approximately 4 months of age).
1. Loop button hooks 2 around the adjustment buttons. 2
 2. Fasten leg hole adjustment button to adjust the leg opening to the smallest, comfortable size. 3
 3. Fasten two upper buttons to use the head support. 4
 4. Fasten shoulder strap adjustment buckle and put head through opening with buckle landing on your back. 5
 5. Fasten waist support buckle and adjust to fit snugly around waist. 6
 6. Place child in the carrier and hold snugly against you with one hand. Use other hand to fasten magnetic shoulder buckles one at a time. 7
 7. Fasten the leg buckles and adjust to appropriate size. 8
 8. Carrier is ready to use in Newborn Mode with Integrated Newborn Seat. 9

Adjust the leg opening

see image 3

1. please must reduce the leg opening to comfortable size by using adjustment button when your child is less than 6.5kg. 3

Infant Facing-In Mode

see images 10 - 15

1. No adjustment buttons are required for Facing-In Baby Seat. 10 Open the leg opening adjustment buttons to get more leg room and more comfortable for your child. 3
2. Fasten shoulder strap adjustment buckle and put head through opening with buckle landing on your back. 11
3. Fasten waist support buckle and adjust to fit snugly around waist. 12
4. Place child in the carrier and hold snugly against you with one hand. Use other hand to fasten magnetic shoulder buckles one at a time. 13
5. Fasten the leg buckles and adjust to appropriate size. 14
6. Carrier is ready to use in Infant Facing In mode. 15

Infant Facing-Out Mode

see images 16 - 22

1. Loop button hooks 1 around the center adjustment buttons. 16
2. Fasten shoulder strap adjustment buckle and put head through opening with buckle landing on your back. 17
3. Fasten waist support buckle and adjust to fit snugly around waist. 18
4. Place child in the carrier and hold snugly against you with one hand. Use the other hand to fasten magnetic shoulder buckles one at a time. 19
5. Fasten the leg buckles and adjust to appropriate size. 20
6. Carrier is ready to use in Infant Facing Out mode. CHECK: Make sure that child's legs fall in the "M" position as recommended by The International Hip Dysplasia Institute. 21 22
7. Open the leg opening adjustment buttons to get more leg room and more comfortable for your child. 3

Back Carry Mode

see images 23 - 35

! It is recommended to practice the back carry mode steps a few times without a child in the carrier before attempting it with a child. Child should NEVER be facing out in back carry mode.

1. Start with child in carrier facing inward and with one hand at a time, loosen both shoulder straps. 23 24
2. With left hand cradling the child, slide right arm out of shoulder strap. 25
3. Slide left arm under the left shoulder adjustment strap. 26
4. Carrier should be hung by one strap over the left shoulder with child secured with right hand against the right hip. 27
5. With right hand securing the child to your hip, use your left hand to slide waist band and shoulder straps around. 28
6. Hold your child to your back with your left hand and loop your right arm up through the right shoulder strap. 29
7. Hold child with right arm and loop left arm down through left shoulder strap. 30
8. Pull down on shoulder adjuster straps to tighten to appropriate fit. 31
9. Adjust center buckle adjuster strap to snug fit. 32
10. CHECK all buckles and snaps are fastened to ensure secure and safe fit. Carrier is now ready to use in back carry mode. 33
11. Optional: Roll up the unused length of the adjustment straps. Secure the roll by wrapping the small loop around it. 34 35
12. Open the leg opening adjustment buttons to get more leg room and more comfortable for your child. 3

Privacy Shield and Sun Protection

see images 36 - 38

! Ensure that the privacy shield is not covering the child's mouth or secured too tight over their head.

1. Make sure head support is fully fastened and pull the sun shade out of the pocket on the top of the head support flap. 36
2. Fasten the sun shade straps to the snap on carrier shoulder straps. 37

3. Sun protection is adjustable and can be adjusted to appropriate fit by attaching to different snaps on the sun protection. 38

All-Season Shield

see images 39 - 41

1. Unroll weather shield from pocket at the bottom of the carrier when needed. 39
2. Attach weather shield by fastening to head support button. Fasten upper two buttons for the smaller baby. 40
Fasten lower two buttons for the older baby. 41

Bib

see images 42 - 45

1. Make sure that the head support is folded down and secured into place with the lower head support buttons. Store the extra length of shoulder buckle adjustment in the pocket on shoulder buckle strap. 42
2. Cover the front of the head support with the bib by attaching it to the two buttons. 43
3. Wrap the top flaps of the bib around both shoulder buckle straps and fasten each hook and loop straps. 44 45

Harness Covers

see images 46 - 48

1. Make sure that the head support is folded down and secured into place with the lower head support buttons. Store the extra length of shoulder buckle adjustment in the pocket on shoulder buckle strap. 46
2. Wrap harness covers around shoulder buckle strap, covering the top head support button, and fasten the hook and loop straps. 47 48

Care and Maintenance

1. Refer to care tag attached to carrier fabric for wash and dry instruction. Carrier MUST be washed inside a mesh laundry bag.
2. Store carrier, harness covers and bibs in mesh laundry bag when not using.
3. It is normal for fabric to fade from sunlight and to show wear and tear after a long period of use.
4. For safety purposes, ONLY use parts provided by joie.
5. CHECK regularly that everything is functioning properly. If any parts are torn, broken or missing, STOP using this product.



Allison Baby UK Ltd.
Venture Point, Towers Business Park
Rugeley, Staffordshire, WS15 1UZ

bring the kids™

Share the joy at joiebaby.com

IM-000491G