

Joie™

0+/1/(0-18kg)

tilt™

child restraint

使用說明書

本產品符合安全標準CNS 11497
及歐盟標準ECE R44測試和認證
組裝及使用本產品前
請先閱讀說明書全文



恭喜您

您剛買了一台通過安全標準和歐盟安全標準檢測的高品質巧兒宜雙向兒童安全座椅，這台兒童安全座椅適用於體重18公斤(約4歲)以下的寶寶。

請仔細閱讀本說明書並依照指示操作，以保障並提供您的寶寶一個安全又舒適的行程。

請保存好本說明書，以利正確使用本產品。

請確定

您的汽車有三點式安全帶裝置

依照各種汽車的廠牌、年份和型號，安全帶可以有不同的設計和長度，本兒童安全座椅僅適用於符合安全標準CNS 3972或歐盟安全標準ECE R16的三點式安全帶的汽車座椅，因為本兒童安全座椅是依安全標準CNS 11497及歐盟標準ECE R44去做測試和認證的。

本兒童安全座椅不適用於裝置有二點式安全帶的汽車座椅。

！請將本說明書妥善存放在底座下

目錄

參照圖示	1-10
中文	
警告	11
緊急情況處理	13
產品資訊	13
產品組件及各部位名稱	15
安裝模式選擇	15
安裝注意事項	16
後向使用(未滿13公斤/0-2歲的寶寶)	16
i 肩帶正確位置	16
ii 小座墊使用方法	17
iii 後向角度調整	17
iv 後向安裝方法	18
v 寶寶乘坐	19
前向使用(9-18公斤/2-4歲的寶寶)	20
i 前向角度調整	20
ii 肩帶正確位置	20
iii 肩帶高低位置調整	21
iv 前向安裝方法	22
v 寶寶乘坐	23
保養維護與保固	24
座布組件拆卸方法	24
English	26-42

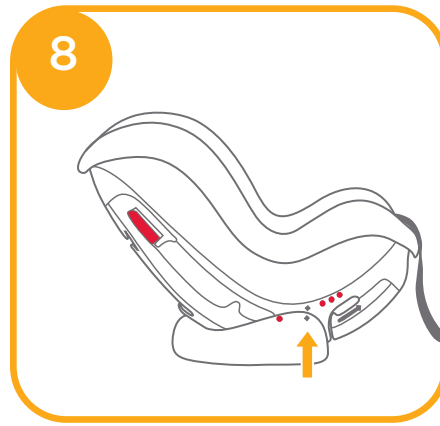
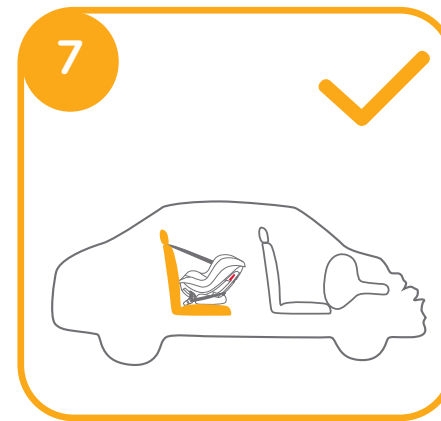
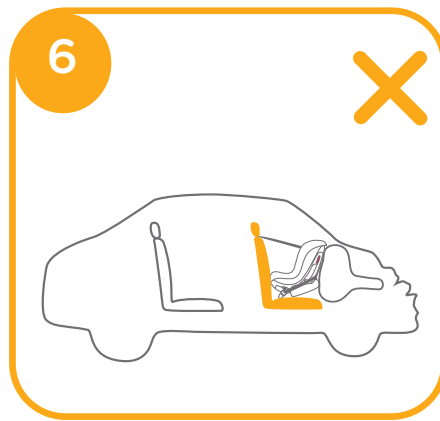
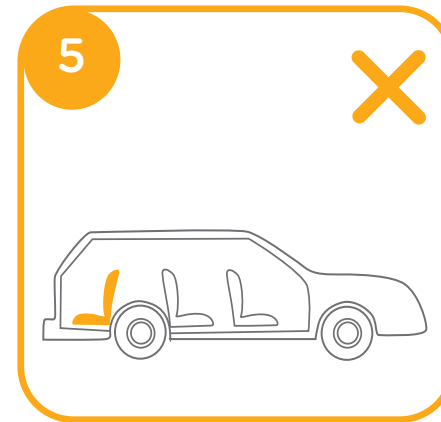
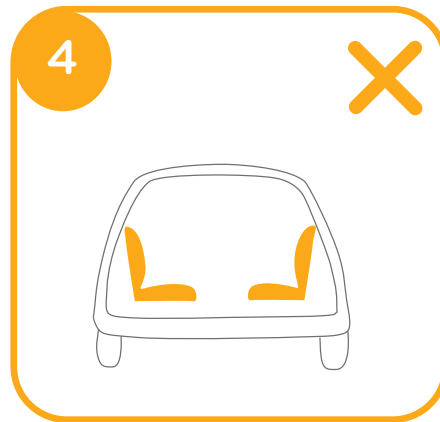
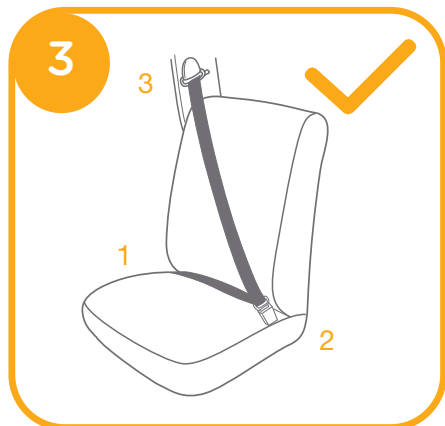
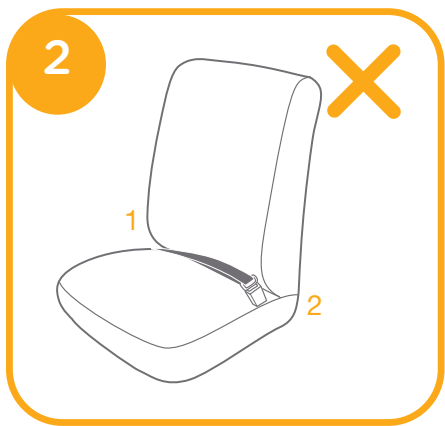
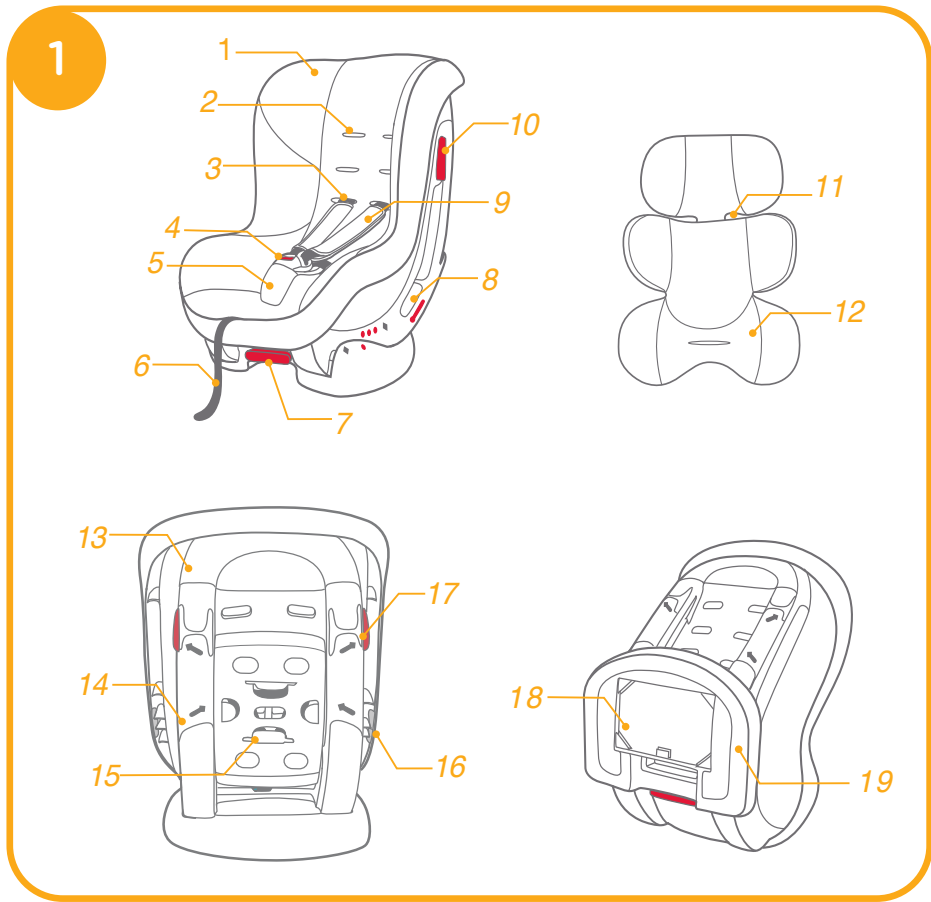

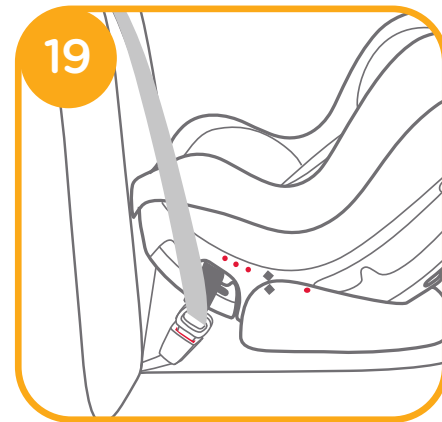
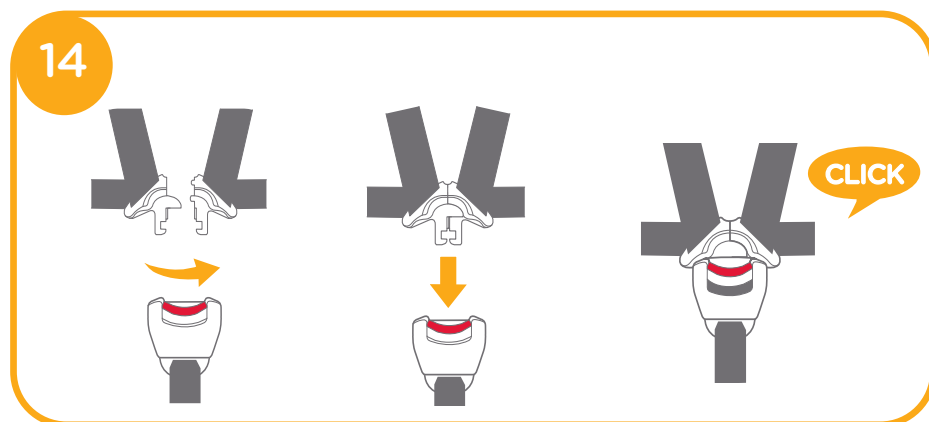
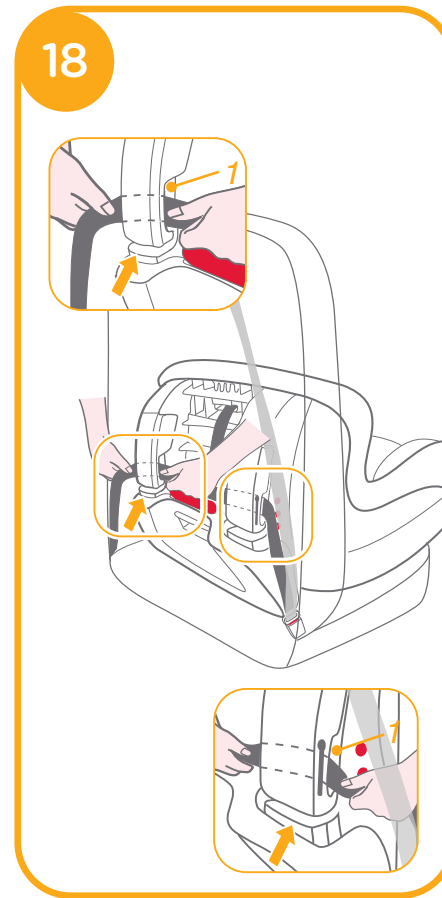
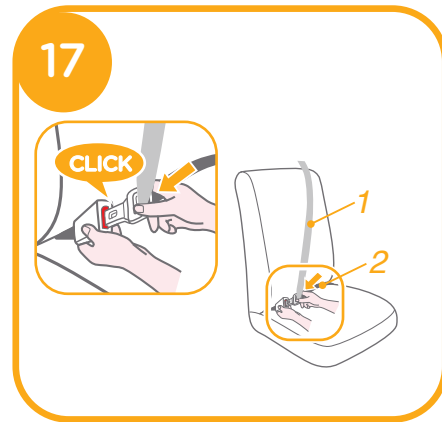
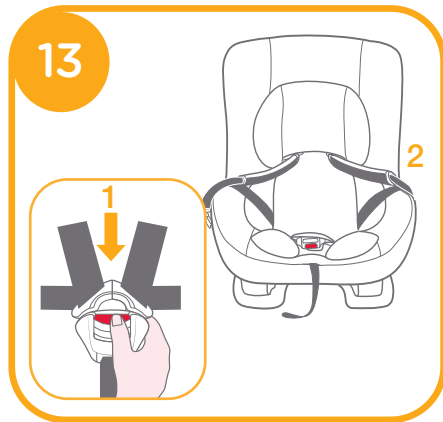
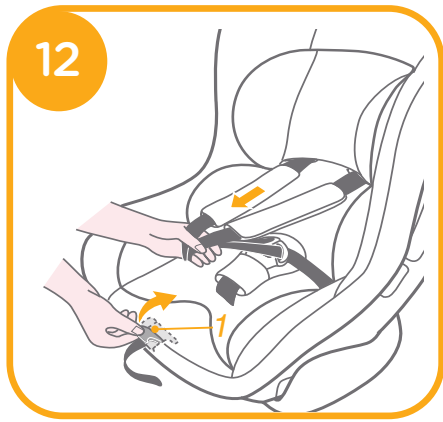
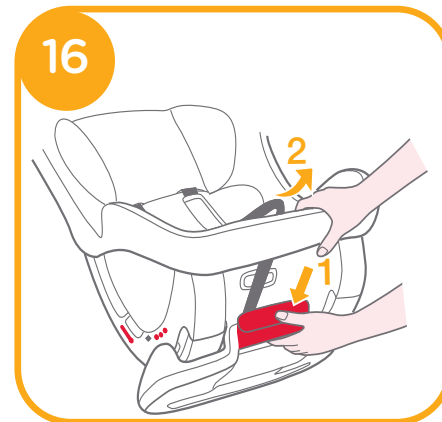
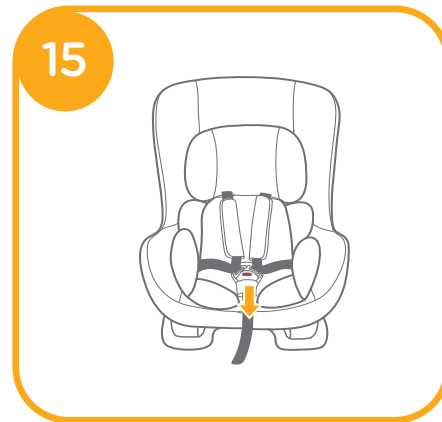
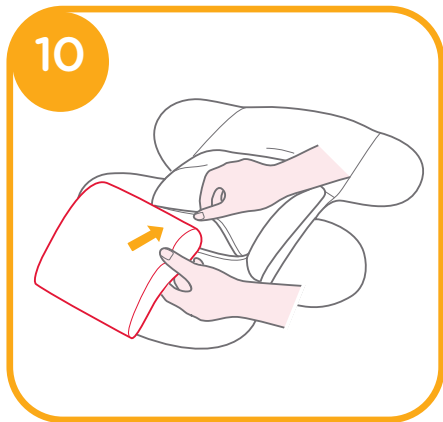

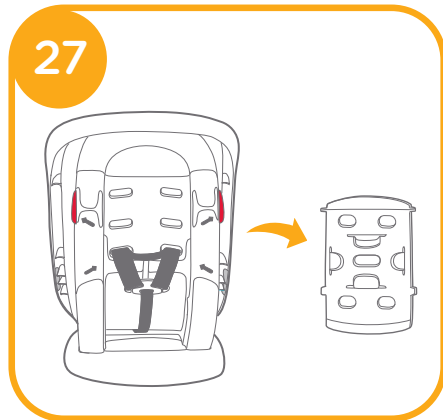
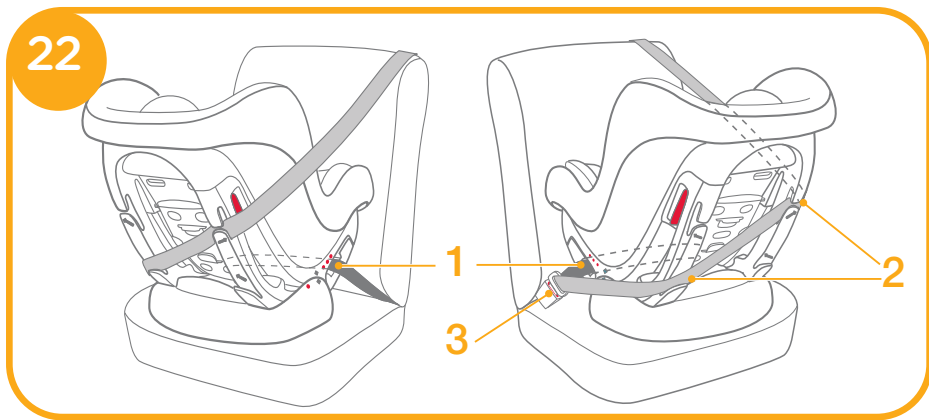
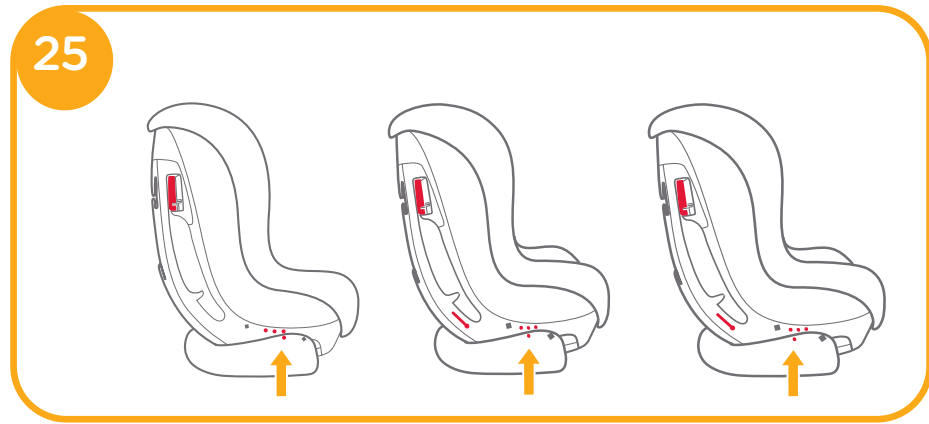
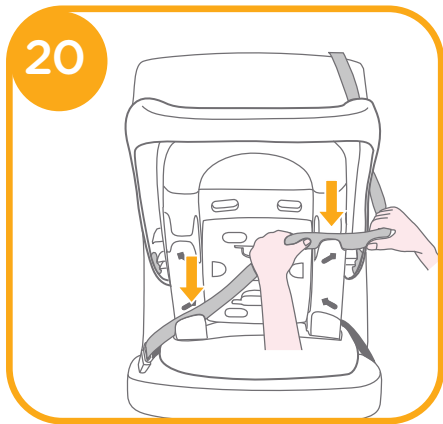

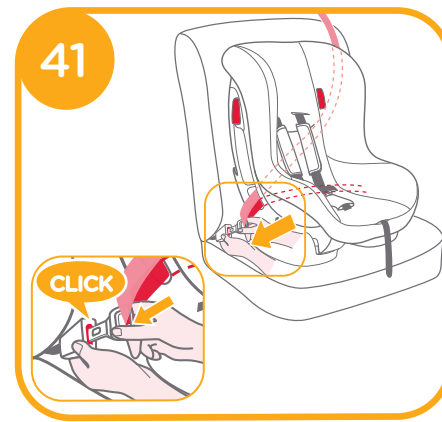
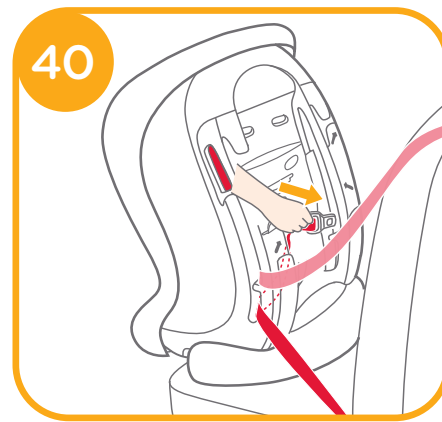
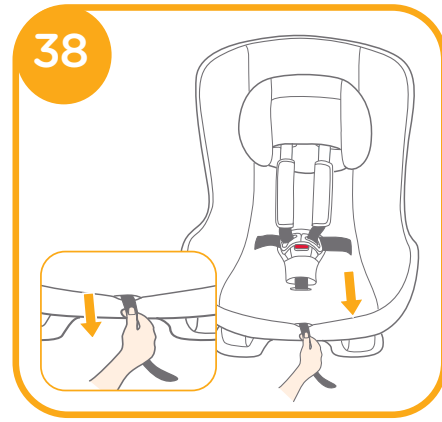
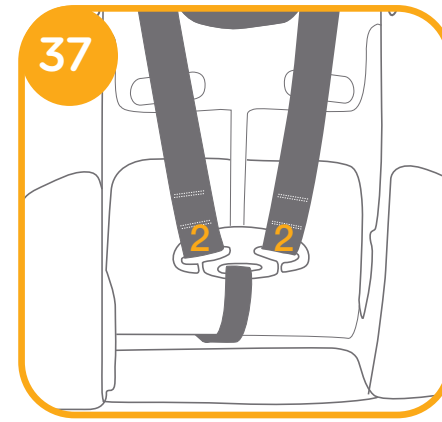
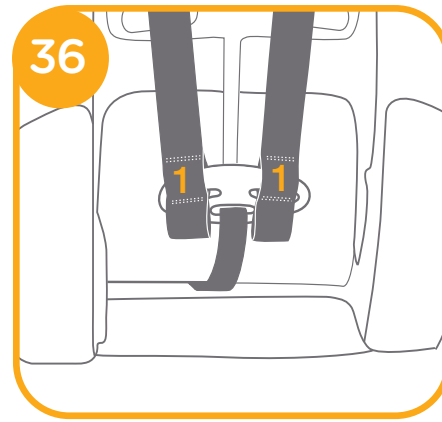
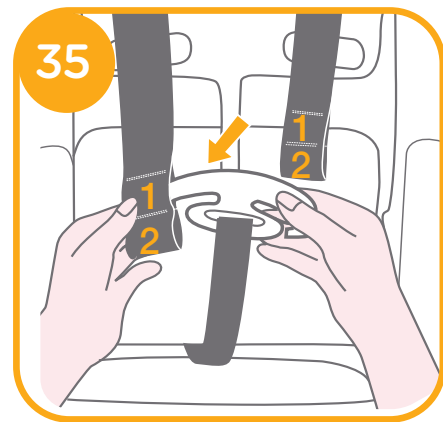
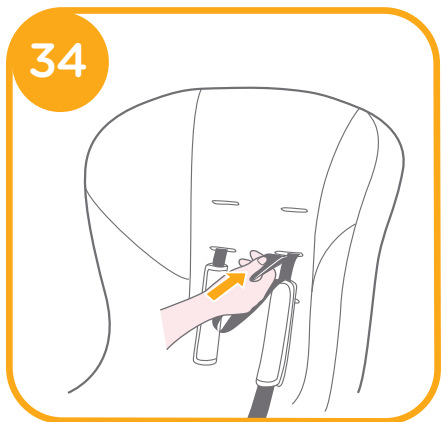
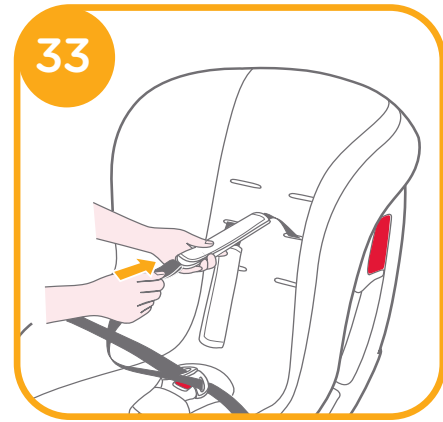
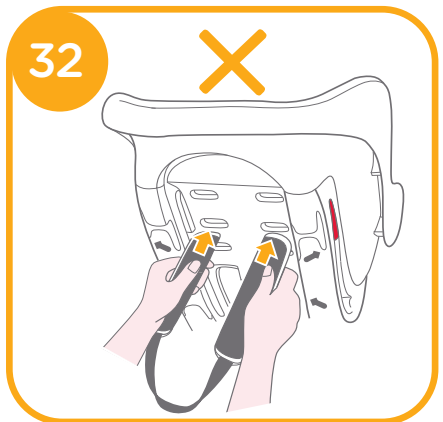
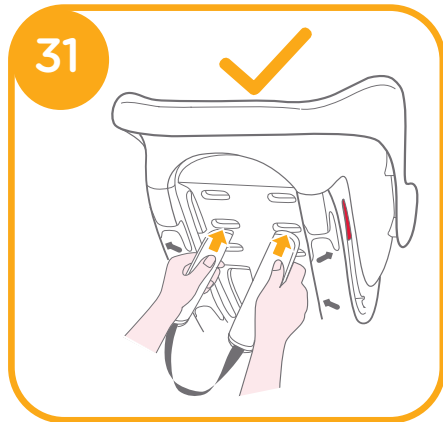
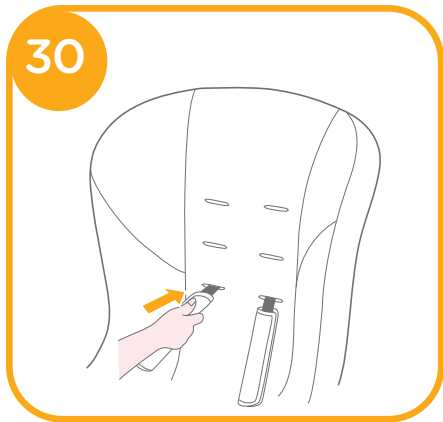

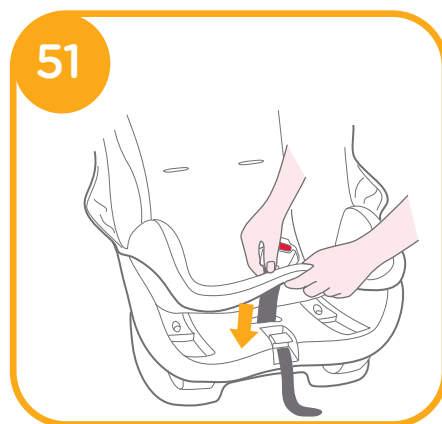
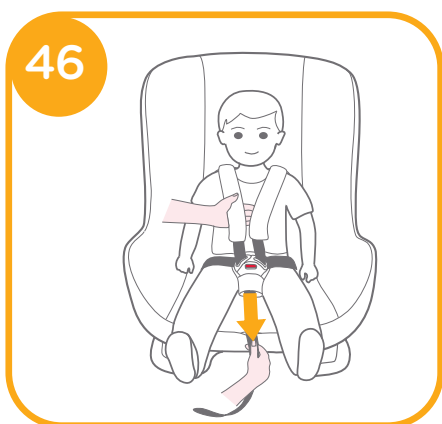
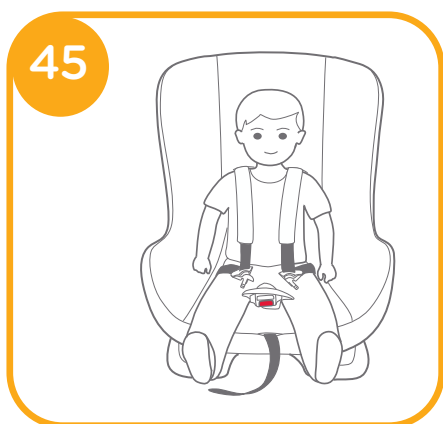
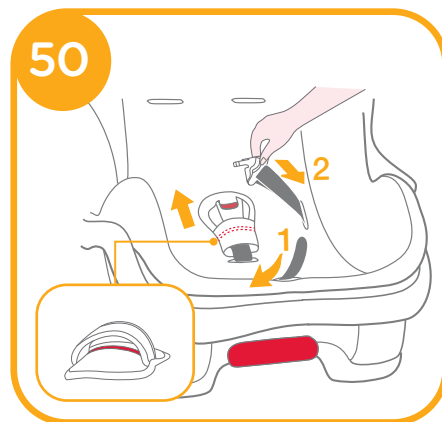
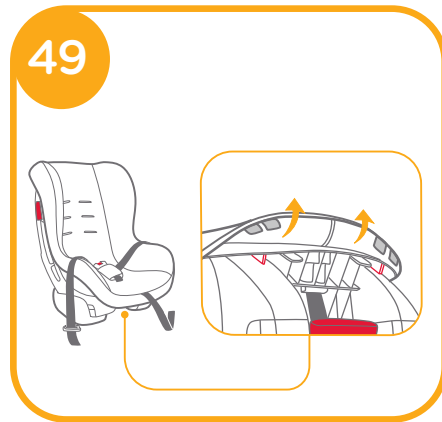
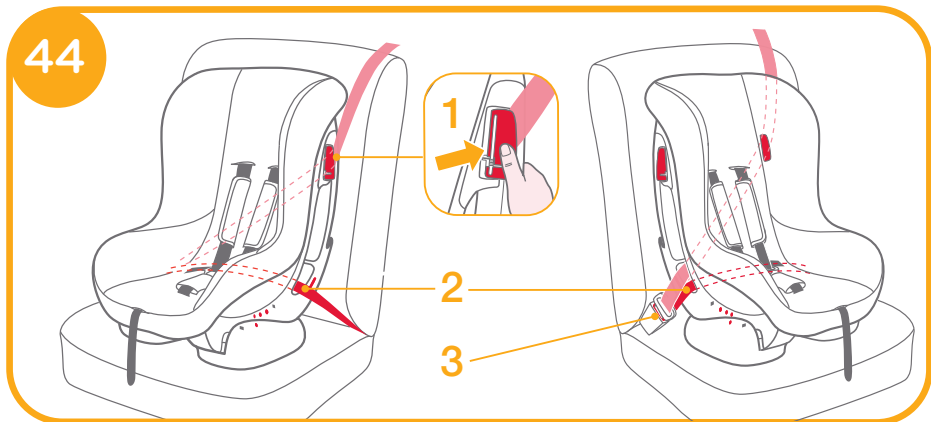
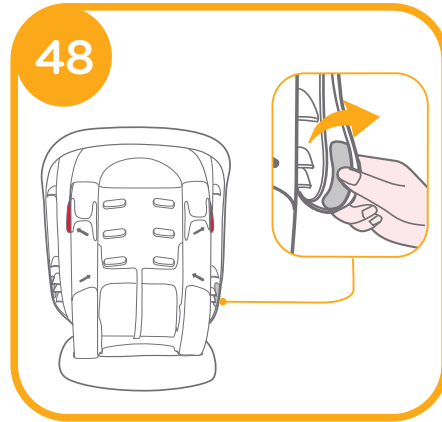
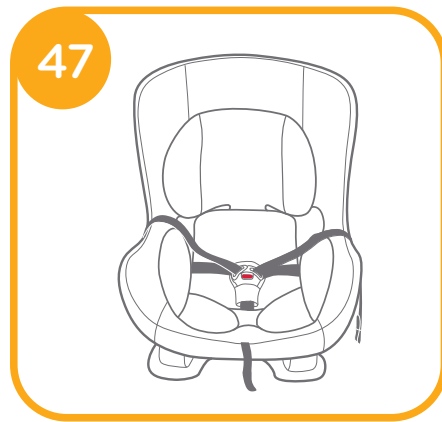
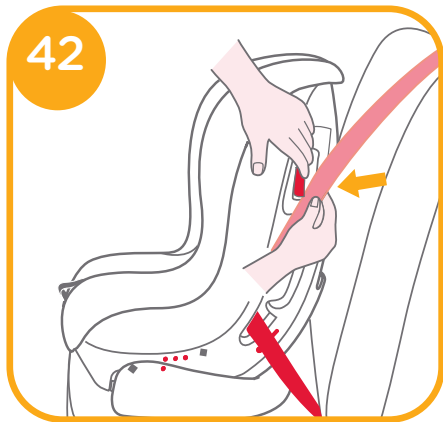

警告

- ! 本兒童安全座椅適用於體重18公斤(約4歲)以下的兒童。
- ! 前向安裝勿提供2歲以下兒童乘坐，超過2歲兒童，仍宜儘量使用後向安裝。
- ! 任何束縛兒童保護裝置至車輛之織帶應束緊，任何束縛兒童之織帶應根據兒童身體進行調節，且此織帶不應扭曲。
- ! 將寶寶置於本兒童安全座椅後，必須正確的扣合及使用兒童安全座椅安全帶，並確保腰部織帶能有效束縛骨盆部位。
- ! 本兒童安全座椅若於意外中遭受劇烈撞擊後，不可繼續使用，應立即更換兒童安全座椅。意外可能導致兒童安全座椅產生潛在危險。
- ! 請勿在兒童安全座椅上進行未經驗證許可之改裝或增加其他裝置以及未依兒童安全座椅製造商提供之安裝說明使用，以免造成受傷或死亡。
- ! 請讓座椅遠離日光，以免產品溫度過高對兒童的皮膚造成傷害。
- ! 在無人照料下，不得讓兒童留在兒童安全座椅內。
- ! 任何行李或其他可能在碰撞中造成傷害之物品應適當牢固。
- ! 當本兒童安全座椅沒有座布時，請勿使用，因座布為兒童安全座椅束縛性能之整體構成要件。
- ! 請勿使用非本製造商推薦的座布，否則會影響兒童安全座椅的總體性能。
- ! 不可使用除使用說明書中所標注以外之其他受力點。
- ! 沒有任何兒童安全座椅可以保證100%遠離傷亡，然而正確的使用本兒童安全座椅可以降低您的寶寶傷亡的機率。
- ! 本兒童安全座椅如有任何損壞或零件缺失時，請勿繼續使用。
- ! 請勿在未閱讀或了解本兒童安全座椅說明書及汽車說明書之前，使用或安裝本兒童安全座椅。
- ! 請勿讓您的寶寶穿著過大的衣物，所穿的衣物必須能讓兒童安全座椅的安全帶適當而安全地扣住於寶寶兩腿之間。
- ! 請勿將未使用汽車安全帶固定住的兒童安全座椅留在車內，以免緊急煞車時，傷害到其他乘客。若不經常使用兒童安全座椅時，請將其搬離汽車座椅。
- ! 嚴禁將本兒童安全座椅裝置於設有正面空氣囊的座位上使用。
- ! 請勿使用二手兒童安全座椅或來歷不明的兒童安全座椅，因為它們可能會有危害寶寶安全的潛在危險。
- ! 不可使用繩子等其他物件代替汽車安全帶，以避免兒童被意外勒住。
- ! 請勿把本兒童安全座椅當作平常的椅子使用，會容易翻倒造成傷害。
- ! 請勿在兒童安全座椅內放置其他內墊物品。
- ! 請勿搬運乘坐着兒童的安全座椅。
- ! 請勿讓汽車車門卡住兒童安全座椅的任何組件。
- ! 使用本產品前，請取掉PE袋和包裝材料，並放到嬰兒和兒童觸摸不到的地方。
- ! 長期不使用兒童安全座椅時，請將其搬離汽車座椅。
- ! 有關零件更換或維修問題，請向代理商查詢。
- ! 以下汽車座椅不能安裝本兒童安全座椅：
 1. 二點式安全帶的汽車座椅。
 2. 相對於汽車的行駛方向，橫向或後向的汽車座椅。
 3. 安裝時不穩定的汽車座椅。

緊急情況處理

遇緊急事故時，需將安全帶剪斷，迅速將乘坐的兒童移離現場。

產品資訊



1. 此為「通用型」兒童保護裝置，符合安全標準CNS11497及歐盟標準ECE R44。其適用大部分（並非全部）之車輛座椅。
2. 若車輛製造商在車主使用手冊中述明其可適用此質量等級之「通用型」兒童保護裝置，則本裝置可安裝於該車輛上。
3. 此兒童保護裝置歸類為「通用型」，比其他無標示此注意事項之兒童保護裝置可適用於較多車輛。
4. 若有疑問，請洽兒童保護裝置代理商或撥0800-001-256 / 02-25781188

Allison Baby UK Ltd.

Venture Point, Towers Business Park,
Rugeley, Staffordshire, WS15 1UZ

www.joiebaby.com

產品名稱	汽車用兒童保護裝置
產品型號	C0902H、C0902FD、C0902FE、C0902JA、C0902JB
適用範圍	18公斤(約4歲)以下的寶寶
主要材質	塑膠、五金、布
質量等級	0+/I
淨重	6.27公斤
產品尺寸	500mmx420mmx620mm
製造日期	詳見產品上貼紙日期(年/月/日)
專利號碼	專利申請中
原產地	中國

委製商	巧兒宜國際股份有限公司
進口商	巧兒宜國際股份有限公司
地址	台北市內湖區瑞光路431號2樓
電話	02-27973000
統一編號	52603333

代理商	奇哥股份有限公司 Chickabiddy Co., Ltd
地址	台北市南京東路四段186號5樓
服務專線	0800-001-256 / 02-25781188
統一編號	04222671
網址	www.chick.com.tw

產品組件 及各部位名稱

圖 1.1	座墊	圖 1.11	頭靠孔
圖 1.2	肩帶孔	圖 1.12	小座墊
圖 1.3	肩帶	圖 1.13	本體
圖 1.4	安全扣	圖 1.14	後向卡槽
圖 1.5	胯帶護片	圖 1.15	後蓋
圖 1.6	調整器織帶	圖 1.16	固定片
圖 1.7	角度調整手把	圖 1.17	前向卡槽
圖 1.8	前向卡槽	圖 1.18	說明書存放處
圖 1.9	肩帶護片	圖 1.19	底座
圖 1.10	安全帶固定夾器		

座墊、肩帶護片、胯帶護片、頭靠、小座墊一起合稱座布。

請確認產品組件沒有遺漏，如有遺漏，請聯繫代理商。

安裝模式選擇

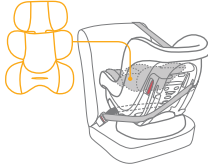
寶寶體重	安裝模式	安裝圖示	參考年齡	座椅段位	說明
未滿 13 公斤	後向 安裝模式		0-2歲	藍色方塊 上下對齊	0-6個月的寶寶 必須使用小座墊， 小座墊可輔助安 全帶綁緊寶寶， 並讓寶寶背部躺 平，避免脊椎彎曲
9-18 公斤	前向 安裝模式		2-4歲	紅色圓點 上下對齊 三段可調 段位	拆除小座墊 (1歲以上的寶寶 不能使用小座墊)

重要事項

1. 前向安裝勿提供2歲以下兒童乘坐，超過2歲兒童，仍宜儘量使用後向安裝。
2. 若寶寶體重同時可適用後向及前向模式，建議使用後向模式，此種模式對寶寶比較安全。

安裝注意事項

- ! 請勿將此兒童安全座椅安裝在二點式安全帶的汽車座椅上，由於此安全帶功能不完善，使用是非常危險的(圖2)
- ! 此兒童安全座椅只適合安裝在設置有三點式安全帶的汽車座椅上(圖3)
- ! 請勿將此兒童安全座椅安裝在相對於汽車的行駛方向橫向(圖4)或後向(圖5)或設有正面空氣囊(圖6)的汽車座椅上。
- ! 請勿將此兒童安全座椅安裝在前座上，防止意外發生時造成寶寶傷亡(圖6)
- ! 必須將此兒童安全座椅安裝於汽車後座(圖7)
- ! 請勿將此兒童安全座椅安裝於可移動的汽車座椅或車門上。

後向使用 (未滿13公斤/0-2歲的寶寶)

參考年齡 新生兒 -2 歲

座椅段位 最後一段(圖8)

! 請先將此兒童安全座椅安裝到汽車後座，再讓寶寶乘坐。

i. 肩帶正確位置

請依照寶寶的身高，選擇一對高度合適的肩帶孔。

! 肩帶的位置需略低於寶寶的肩膀，肩帶位置太高或者太低都是不正確的(圖9)

! 若肩帶高低位置調節不正確，意外發生時可能造成寶寶被拋出兒童安全座椅的危險。

ii. 小座墊使用方法

提示

1. 小座墊設計是保護寶寶用的，0-6個月的寶寶必須使用小座墊。
2. 拆除小座墊中的泡棉後，請將泡棉存放於寶寶無法接觸到的地方。
3. 使用小座墊時須裝上泡棉(圖10)

1. 拉開頭靠，將肩帶穿過頭靠孔，固定頭靠(圖11)

! 安裝頭靠前，請確認肩帶高度已調整到適當位置，請參考P.16(肩帶正確位置)和P.21(肩帶高低位置調整)

2. 扳動織帶長度調整器，同時將肩帶拉出至適當長度(圖12)

圖12.1 織帶長度調整器

3. 按壓紅色按鈕，將安全扣打開，將小座墊裝入兒童安全座椅中(圖13)

4. 扣好安全扣(圖14)

5. 拉緊調整器織帶(圖15)

iii. 後向角度調整

按壓角度調整手把(圖16.1)，同時拉動兒童安全座椅本體(圖16.2)將座椅角度調整到最後一段(圖8)

角度標示：上下藍色方塊對齊。角度調整好後如圖8所示。

iv. 後向安裝方法

提示

1. 安裝兒童安全座椅前，請確認肩帶高低已調整至適當位置，請參考P.16(肩帶正確位置)和P.21(肩帶高低位置調整)。
2. 請先將兒童安全座椅角度調整至最後一段，角度標示：上下藍色方塊對齊(圖8)
3. 安裝和調整汽車安全帶時，須注意汽車安全帶肩帶和腰帶都不可以扭曲或妨礙汽車安全帶的正常功能。

1. 拉出汽車安全帶，將安全帶插扣片插到插扣座內(圖17)

圖17.1 肩帶

圖17.2 腰帶

2. 將兒童安全座椅向後傾斜一定角度，將腰帶穿入本體下方的2個後向卡槽內(圖18)

圖18.1 後向卡槽

腰帶穿好後如圖19所示。

3. 將肩帶依次卡入本體背面的2個後向卡槽內(圖20)

! 肩帶須穿入後向卡槽內。

4. 持續緊壓兒童安全座椅，並用力拉緊汽車安全帶，使汽車安全帶緊實的繫住兒童安全座椅(圖21)

! 請將兒童安全座椅前後搖晃作確認。

! 汽車安全帶母扣段若太長，汽車安全帶無法綁緊不能使用。(圖21.3)

汽車安全帶安裝好後如圖22所示

! 腰帶穿入後向卡槽(圖22.1)

! 肩帶穿入後向卡槽(圖22.2)

! 汽車插扣片和插扣座正確扣合(圖22.3)

V. 寶寶乘坐

提示

1. 0-6個月的寶寶必須使用小座墊。
2. 請先將兒童安全座椅安裝到汽車後座，再讓寶寶乘坐。
3. 當寶寶放入座椅後，請確認肩帶高度是否調整到適當位置，請參考P.16(肩帶正確位置)和P.21(肩帶高低位置調整)。

1. 扳動織帶長度調整器，同時將肩帶拉出至適當長度(圖12)

圖12.1 織帶長度調整器

2. 按壓紅色按鈕，打開安全扣，再將安全帶左右打開(圖13)
3. 將寶寶放入兒童安全座椅內，再將寶寶兩臂穿過安全帶(圖23)
4. 扣好安全扣(圖14)
5. 下拉調整器織帶，調整肩帶至適當長度，以配合寶寶身形，並注意寶寶與肩帶之間須可以放進一個手掌的厚度(圖24)

前向使用 (9-18公斤/2-4歲的寶寶)

參考年齡 2 - 4 歲

座椅段位 1 - 3 段 (上下紅色圓點對齊圖25)

! 請先將此兒童安全座椅安裝到汽車座椅上，再讓寶寶乘坐。

i. 前向角度調整

按壓角度調整手把(圖16.1)，同時推動兒童安全座椅本體(圖16.2)

將座椅角度調整到適當段位，角度標示：上下紅色圓點對齊。

角度調整好後如圖25所示。

ii. 肩帶正確位置

請依照寶寶的身高，選擇一對高度合適的肩帶孔。

! 肩帶的位置需略高於寶寶的肩膀，肩帶位置太高或者太低都是不正確的(圖26)

! 若肩帶高低位置調節不正確，意外發生時可能造成寶寶被拋出兒童安全座椅的危險。

iii. 肩帶高低位置調整

提示

1. 肩帶護片為防止寶寶滑動之重要部件，請勿自行移除。
2. 請先裝肩帶護片，再裝肩帶。
3. 安裝過程中，須注意肩帶不能扭曲。

拆卸肩帶

1. 扳動織帶長度調整器，同時將肩帶拉出至適當長度(圖12)

圖12.1 織帶長度調整器

2. 移除後蓋(圖27)
3. 分別將座椅背面的2條肩帶從T型鐵片上取下(圖28)
4. 拉出肩帶(圖29)
5. 將肩帶護片從肩帶孔中穿出(圖30)

安裝肩帶

1. 選擇適當肩帶孔位，從座椅背面裝入肩帶護片(圖31)

裝肩帶護片時，須布面朝上，橡膠面朝上會影響安全帶的正常功能(圖32)

2. 將肩帶穿入肩帶護片(圖33)
為防止肩帶扭曲，請先扣好安全扣。
3. 將肩帶穿入肩帶孔(圖34)
4. 依以上步驟裝入另一側肩帶。
5. 將T型鐵片重新穿入肩帶末端的織帶環中(圖35)

! 肩帶末端有兩對織帶環1、2。

! 較小兒童乘坐時，可選用織帶環1，且肩帶末端須置於T型鐵片前面(圖36)

! 較大兒童乘坐時，可選用織帶環2(圖37)

6. 將肩帶穿過頭靠孔來固定頭靠，然後拉緊調整器織帶(圖38)
7. 將後蓋重新裝上(圖39)

iv. 前向安裝方法

提示

1. 安裝兒童安全座椅前，請先調整好肩帶高度，使肩帶略高於肩膀，請參考P.20(肩帶正確位置)和P.21(肩帶高低位置調整)。
2. 請先調整好兒童安全座椅的角度，前向共有3段，角度標示:上下紅色圓點對齊(圖25)
3. 安裝和調整汽車安全帶時，須注意安全帶肩帶和腰帶都不可以扭曲或妨礙汽車安全帶的正常功能。

1. 拉出汽車安全帶後，將兒童安全座椅傾斜一定角度，將汽車安全帶依次穿入本體背面的2個前向卡槽內(圖40)
2. 將安全帶插扣片插到插扣座內(圖41)
3. 打開安全帶固定夾器，將安全帶穿入安全帶固定夾器中(圖42)
4. 持續緊壓兒童安全座椅，並用力拉緊汽車安全帶，使汽車安全帶緊實的繫住兒童安全座椅(圖43)

! 請將兒童安全座椅前後搖晃作確認。

! 汽車安全帶母扣段若太長，汽車安全帶無法綁緊不能使用(圖43.1)

汽車安全帶安裝好後如圖44所示

! 肩帶穿過安全帶固定夾器，並確實壓下安全帶固定夾器(圖44.1)

! 腰帶穿過前向卡槽(圖44.2)

! 汽車插扣片和插扣座正確扣合(圖44.3)

V. 寶寶乘坐

提示

1. 前向使用時，請勿使用小座墊。
2. 請先將兒童安全座椅安裝到汽車上，再讓寶寶乘坐。
3. 當寶寶放入座椅後，請確認肩帶高度是否調整在適當位置，請參考P.20(肩帶正確位置)和P.21(肩帶高低位置調整)。

1. 扳動織帶長度調整器，同時將肩帶拉出至適當長度(圖12)

圖12.1 織帶長度調整器

2. 按壓紅色按鈕，先打開安全扣，再打開左右兩側的安全帶(圖13)
3. 將寶寶放入兒童安全座椅後，將寶寶兩臂穿過安全帶(圖45)
4. 扣好安全扣(圖14)
5. 下拉調整器織帶，調整肩帶至適當長度，以配合寶寶身形，並注意寶寶與肩帶之間須可以放進一個手掌的厚度(圖46)

保養維護與保固

- ! 拆除小座墊中的泡棉後，請將泡棉存放於寶寶無法接觸到的地方。
- ! 請以30度以下水溫清洗。
- ! 請勿使用熨斗熨燙。
- ! 請勿使用漂白劑及乾洗。
- ! 請勿使用未經稀釋的中性清潔劑、汽油或其他有機溶劑清洗兒童安全座椅，否則可能對兒童安全座椅造成損壞。
- ! 請勿大力扭乾，過分大力扭乾可能留下皺褶。
- ! 請於陰涼處鋪平晾乾。
- ! 當長時間不使用本兒童安全座椅時，請將本兒童安全座椅從汽車座椅上拆除，並存放於陰涼處及寶寶不易接觸的地方。

延長保固服務

請於購買起一個月內至奇哥官網進行登錄，登錄成功後即享有商品延長一年保固服務。



座布組件拆卸方法

1. 移除後蓋，將肩帶從T型鐵片上取下，參考P.21(拆卸肩帶)。
2. 按壓安全扣，將小座墊取出(圖47)
3. 將座布兩側的固定片從本體側面的2個卡槽取出(圖48)
4. 將座布前端的固定片從本體下面的2個卡槽取出(圖49)
5. 將調整器織帶和左右兩側的安全帶從座布中穿出(圖50)
6. 將胯帶從胯帶護片內的鬆緊帶中穿出，移除胯帶護片(圖50)
7. 將安全扣從胯帶孔中穿出，可移除座布(圖51)
反向操作即可組裝座布(圖52)

Note

Joie™

0+/1/(0-18kg)

tilt™ child restraint

Instruction Manual

This child restraint is approved to Chinese National Standard 11497 and UN ECE regulation 44, 04 series of amendments.

Please read all the instructions in this manual before installing and using the product.



Congratulations

You have purchased a high quality, fully certified child safety child restraint. This product is suitable for the use of children weighing UNDER 18kg (approximately 4 years old or under).

Carefully read this Instruction Manual and follow the installing steps because this is the **ONLY** way to protect your child from serious injury or death in case of an accident, and to provide comfort to your child while using this product.

Keep this instruction manual for future reference.

Please Confirm

Make sure that your vehicle is equipped with 3-point retractor safety-belt.

Seat belts may be different in design and length according to maker, manufacturing date, and type of the vehicle. This child restraint is only suitable for use in the listed vehicles fitted with 3-point retractor safety-belts, approved to CNS 3972 or UN ECE regulation 16 or other equivalent standards. This child restraint is approved to CNS 11497 and UN ECE regulation 44, 04 series of amendments.

! Please keep the instruction manual in the bottom storage compartment of the base for future reference.

Contents

Reference Figures	1 - 10
English	
Warning	29
Emergency	31
Product Information	31
Parts List	32
Choose the Installation Mode	33
Concerns on Installation	34
Installation for Rearward Facing Mode	34
For Child under 13kg / 0 - 2 years old	
i Proper Position of the Shoulder Harnesses	34
ii Use of Small Seat Pad	35
iii Rearward Reclining Angle Adjustment	35
iv Rearward Facing Installation	36
v Securing your Child in the child restraint	37
Installation for Forward Facing Mode	38
For Child between 9 -18kg / 2 - 4 years old	
i Forward Reclining Angle Adjustment	38
ii Proper Position of the Shoulder Harnesses	38
iii Shoulder Harnesses Height Adjustment	39
iv Forward Facing Installation	40
v Securing your Child in the child restraint	41
Cleaning Method	42
Detach Soft Goods	42

Warning

- ! This child restraint is designed ONLY for child weighing under 18kg (approximately 4 years old or under).
- ! DO NOT use forward facing mode when the child is under 2 years old, It is still advisable to use rearward facing mode when the child is over 2 years old.
- ! Any straps holding the restraint to the vehicle should be tight, that any straps restraining the child should be adjusted to the child's body, and that straps should not be twisted.
- ! After your child is placed in this child restraint, the safety belt must be used correctly, and ensure that any lap strap is worn low down, so that the pelvis is firmly engaged.
- ! The child restraint should be changed when it has been subject to violent stresses in an accident. An accident can cause damage to the child restraint that you cannot see.
- ! Concern the danger of making any alterations or additions to the device without the approval of the Type Approval Authority, and a danger of not following closely the installation instructions provided by the child restraint manufacturer.
- ! Please keep this child restraint away from sunlight, otherwise it may be too hot for the child's skin.
- ! Child is not left in the child restraint system unattended.
- ! Any luggage or other objects liable to cause injuries in the event of a collision shall be properly secured.
- ! The child restraint shall not be used without the soft goods.
- ! The soft goods should not be replaced with any other than the one recommended by the manufacturer, because the soft goods constitutes an integral part of the restraint performance.
- ! DO NOT use any load bearing contact points other than those described in the instructions and marked on the child restraint.
- ! NO child restraint can guarantee full protection from injury in an accident. However, proper use of this child restraint will reduce the risk of serious injury or death to your child.
- ! DO NOT use this child restraint if it has damaged or missing parts.
- ! DO NOT use or install this child restraint until you read and understand the instructions in this manual and in your vehicle owner's manual.

- ! DO NOT have your child in unfitted clothes because this may prevent your child from being properly and securely fastened by the shoulder harnesses and the harnesses between thighs.
- ! DO NOT leave this child restraint unbelted or unsecured in your vehicle because unsecured child restraint can be thrown around and may injure occupants in a sharp turn, sudden stop, or collision. Remove it if not in regular use.
- ! NEVER install this child restraint on any vehicle seat equipped with safety airbags.
- ! NEVER use a second-hand child restraint or a child restraint whose history you do not know because they may have structural damage that endangers your child's safety.
- ! NEVER use ropes or any other substitutes in place of seat belts in case of injuries from restraint.
- ! DO NOT use this child restraint as a regular chair as it tends to fall down and injure the child.
- ! DO NOT put anything other than the recommended inner cushions in this child restraint.
- ! DO NOT carry this child restraint with a child in it.
- ! Make sure that no part of the child restraint become trapped by a movable seat or in a door of the vehicle.
- ! To avoid suffocation, remove plastic bag and packaging materials before using this product. The plastic bag and packaging materials should then be kept away from babies and children.
- ! Remove this child restraint from the vehical seat when it is not in use.
- ! Consult the distributor for issues concerning maintenance, repair and part replacement.
- ! DO NOT install this child restraint under the following conditions:
 1. Vehicle seats with 2-point safety belts.
 2. Vehicle seats facing sideward or rearward with respect to the running direction of the vehicle.
 3. Vehicle seats unstable during installation.

Emergency

In case of emergency or accidents, it is most important to have your child taken care of with first aids and medical treatment immediately.

Product Information



1. This is a 'Universal' child restraint. It is approved to CNS 11497 and UN ECE regulation 44, 04 series of amendments, for general use in vehicles and it will fit most, but not all, car seats.
2. A correct fit is likely if the vehicle manufacturer has declared in the vehicle handbook that the vehicle is capable of accepting a 'Universal' child restraint for this age group.
3. This child restraint has been classified as 'Universal' under more stringent conditions than those which applied to earlier designs which do not carry this notice.
4. If in doubt please consult the child restraint distributor or call 0800-001-256 / 02-25781188 directly.

Allison Baby UK Ltd.

Venture Point, Towers Business Park,
Rugeley, Staffordshire, WS15 1UZ
www.joiebaby.com

Product	Child Restraint
Model	C0902H, C0902FD, C0902FE, C0902JA, C0902JB
Suitable for	Child weighing under 18kg (approximately 4 years old or under)
Materials	Plastics, metal, fabrics
Mass Group	0+ / I
Net Weight	6.27kg
Product Size	500mmx420mmx620mm
Date	Please see detailed date on label (year / month / day)
Patent No.	Patents pending
Made in	China
Distributor	Chickabiddy Co., Ltd
Address	5 th FL, 186, Nanking E. Rd, Sec. 4, Taipei, Taiwan 10595
Tel.	0800-001-256 / 02-25781188
Website	www.chick.com.tw

Parts List

Fig. 1.1	Seat Pad	Fig. 1.11	Head Support Slot
Fig. 1.2	Shoulder Harness Slot	Fig. 1.12	Small Seat Pad
Fig. 1.3	Shoulder Strap	Fig. 1.13	Body
Fig. 1.4	Buckle	Fig. 1.14	Rearward Safety-belt Slot
Fig. 1.5	Crotch Strap	Fig. 1.15	Webbing Cover
Fig. 1.6	Adjustment Webbing	Fig. 1.16	Fastening Piece
Fig. 1.7	Reclining Adjustment Handle	Fig. 1.17	Forward Safety-belt Slot
Fig. 1.8	Forward Safety-belt Slot	Fig. 1.18	Instruction Manual Storage Compartment
Fig. 1.9	Shoulder Harness	Fig. 1.19	Base
Fig. 1.10	Lock-off Device		

Soft goods include Seat Pad, Shoulder Strap, Crotch Strap, Head Support and Small Seat Pad.

Please make sure there are no missing parts. Please contact the distributor if anything is missing.

Choose the Installation Mode

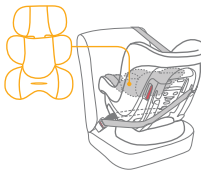
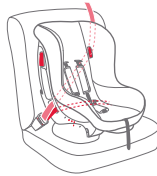
Child's Weight	Installation Mode	Figure for Installation	Reference Age	Seat Position	Instructions
<13kg	Rearward facing mode + Small Seat Pad		< 2 years	Align top blue diamond and bottom blue diamond	Small Seat Pad must be used for children 0-6 months. Small Seat Pad can help restrain the child tightly and level the child's back to avoid cyrtosis
9 - 18kg	Forward facing mode		2 year to 4 years	Align top red dot and bottom red dot for 3 adjustment positions	Disassemble the Small Seat Pad (Small Seat Pad must not be used for child over 1 year old)

Important

1. DO NOT use forward facing mode when the child is under 2 years old, It is still advisable to use rearward facing mode when the child is over 2 years old.
2. When the child is suitable for both forward and rearward facing modes, it is recommended to install this child restraint in the rearward facing mode as it is relatively safer.

Concerns on Installation

- ! DO NOT install this child restraint on vehicle seats with Lap Belts. (Fig. 2)
- ! This child restraint is only suitable for vehicle seats with 3-Point Retractor Safety Belts. (Fig. 3)
- ! DO NOT install this child restraint on vehicle seats that face sideward (Fig. 4) or rearward (Fig. 5) with respect to the moving direction of the vehicle.
- ! DO NOT install this child restraint on the front vehicle seats in case injuries might happen to the child when there is an accident. (Fig. 6)
- ! This child restraint must be installed on the rear vehicle seat. (Fig. 7)
- ! DO NOT install this child restraint on movable vehicle seats or vehicle doors during installation.

Installation for Rearward Facing Mode (for Child under 13kg / 0-2 years old)

Reference age New born - 2 years old

Seat position Last position (with top blue diamond and bottom blue diamond aligned, as Fig. 8)

- ! Please install the child restraint on the vehicle seat, and then put the child in the child restraint.

i. Proper Position of the Shoulder Harnesses

Please choose the proper pair of shoulder harness slots according to the infant's height.

- ! The shoulder harness slots shall be slightly below the infant's shoulder. Shoulder harnesses too high or too low are not safe. (Fig. 9)
- ! If the shoulder harnesses are not at proper height, the infant may be thrown from the child restraint when there is an accident.

ii. Use of Small Seat Pad

Note

1. Small seat pad is for child's protection. Small seat pad must be used for children 0-6 months.
2. After removing the foam from the small seat pad, please store it in a place where the child cannot access it.
3. Before using the small seat pad, please assemble the foam. (Fig. 10)

1. Pull the head support aside and thread the shoulder harness through the head support slot to fasten the head support. (Fig. 11)

Before assembling the head support, please check whether the shoulder harnesses are at the proper height. Please refer to P. 34 (Proper Position of the Shoulder Harnesses) & P. 40 (Shoulder Harnesses Height Adjustment).

2. While pulling up the webbing adjuster, pull out the shoulder harnesses to proper length. (Fig. 12)

Fig. 12.1 Webbing adjuster

3. Press the red button to disengage the buckle (Fig. 13.1), and then place the small seat pad in the child restraint. (Fig. 13.2)
4. Engage the buckle. (Fig. 14)
5. Pull the adjustment webbing tight. (Fig. 15)

iii. Rearward Reclining Angle Adjustment

While pushing the reclining adjustment handle (Fig. 16.1), pull the child restraint from the first position to the last position. (Fig. 16.2)

Angle indication: The top blue diamond and bottom blue diamond are aligned. The reclining angle is shown as Fig. 8

iv. Rearward Facing Installation

Note

1. Make sure the shoulder harness is adjusted to proper height before installing this child restraint. Please refer to P. 34 (Proper Position of the Shoulder Harnesses) & P. 39 (Shoulder Harnesses Height Adjustment).
2. First adjust the angle of the child restraint to the last position. Angle indication: Align the top blue diamond and bottom blue diamond. (Fig. 8)
3. When installing and adjusting the safety belts, make sure that both the shoulder belt and the waist belt are not twisted and will not stop the safety belts from functioning properly.

1. Pull out the safety belt and engage the vehicle buckle tongue into the buckle. (Fig. 17)

Fig. 17.1 Shoulder belt Fig. 17.2 Waist belt

2. Incline the child restraint rearward and thread the belt through the two rearward blue safety-belt slots underneath the body. (Fig. 18)

Fig. 18.1 / Fig. 18.2 Safety-belt slot

The correctly assembled belt is shown as Fig. 19.

3. Fasten the belts in the two rearward blue safety-belt slots at the back of the body. (Fig. 20)

! Shoulder belt must pass through the rearward safety-belt slot.

4. While pressing the child restraint, pull the belts to fasten the child restraint tightly and securely. (Fig. 21)

! Please check by moving the child restraint back and forth.

! The child restraint can not be used if the vehicle safety belt with female buckle is too long to tie the base. (Fig. 21.3)

Correctly assembled vehicle belt is shown as Fig. 22

! Waist belt passes through the rearward safety-belt slots, as Fig. 22.1

! Shoulder belt must pass through the rearward safety-belt slots, as Fig. 22.2

! The vehicle buckle tongue is engaged with the buckle correctly, as Fig. 22.3

v. Securing your Child in the child restraint

Note

1. Small seat pad must be used for children 0-6 months.
2. Please install the child restraint on the vehicle seat, and then put the child in the child restraint.
3. After the child is placed into the seat, check whether the shoulder harnesses are at proper height. Please refer to **P. 34** (Proper Position of the Shoulder Harnesses) & **P. 39** (Shoulder Harnesses Height Adjustment).

1. Pull up the webbing adjuster, while pulling out the shoulder harnesses to the proper length. (Fig. 12)

Fig. 12.1 Webbing adjuster

2. Press the red button to disengage the buckle (Fig. 13.1), and then leave the harnesses on the left side and right side respectively (Fig. 13.2)
3. Place the child in the child restraint and pass both arms through the harnesses. (Fig. 23)
4. Engage the buckle. (Fig. 14)
5. Pull down the adjustment webbing and adjust it to the proper length to make sure your child is snugly secured. (Fig. 24)

! Make sure the space between the child and the shoulder harness is about the thickness of one hand.

Installation for Forward Facing Mode (for Child between 9-18kg / 2-4 years old)

Reference age 2 - 4 years old

Seat position Position 1 - Position 3 (with top red dot and bottom red dot aligned, as Fig. 25)

! Please install the child restraint on the vehicle seat, and then put the child in the child restraint.

i. Forward Reclining Angle Adjustment

While pushing the reclining adjustment handle (Fig. 16.1), push the child restraint to the proper position (Fig. 16.2) Angle indication: With the top red dot and bottom red dot aligned.

The reclining angles are shown as Fig. 25

ii. Proper Position of the Shoulder Harnesses

Please choose the proper pair of shoulder harness slots according to the child's height.

! The shoulder harness slots shall be slightly above the child's shoulder. Shoulder harnesses too high or too low are not safe. (Fig. 26)

! If the shoulder harnesses are not at proper height, the child might be thrown from the child restraint when there is an accident.

iii. Shoulder Harnesses Height Adjustment

Note

1. DO NOT remove the shoulder straps as they are important for preventing the slippage of the child.
2. Please assemble the shoulder straps first, then the shoulder harnesses.
3. During assembling, make sure the shoulder harnesses are not twisted.

Disassembly of the Shoulder Harnesses.

1. Pull up the webbing adjuster, while pulling the shoulder harnesses to the proper position. (Fig. 12)

Fig. 12.1 Webbing adjuster

2. Remove the webbing cover from the body. (Fig. 27)
3. At the back of the seat, disassemble the two shoulder harnesses from the T-shape steel plate. (Fig. 28)
4. Pull out the shoulder harnesses. (Fig. 29)
5. Thread the shoulder strap through the shoulder harness slots. (Fig. 30)

Assembly of the Shoulder Harnesses.

1. Choose the proper shoulder harness slots and thread the shoulder straps through them. (Fig. 31)
 - ! It will affect the normal function of the harnesses with the rubber side upward. (Fig. 32)
2. Thread the shoulder harness through the shoulder strap. (Fig. 33)
 - ! To avoid the shoulder harnesses from getting twisted, please engage the buckle first.
3. Thread the shoulder harness through the shoulder harness slot. (Fig. 34)
4. Assemble the shoulder harness on the other side following the above steps.
5. Thread the loops on the shoulder harnesses through the T-shape steel plate at the back of the seat. (Fig. 35)

- ! The end of the shoulder harness has two harness loops 1, 2.
- ! For a smaller baby, use the upper harness loop 1, and the ends of the shoulder harnesses must hang in front of the T-shape steel plate. (Fig. 36)

- ! For a bigger baby, use the lower harness loop 2. (Fig. 37)

6. Thread the shoulder harness straps through the head support slot to fasten the head support to the straps, and then pull the adjustment webbing tight. (Fig. 38)
7. Reassemble the webbing cover to the body. (Fig. 39)

iv. Forward Facing Installation

Note

1. Please adjust the shoulder harnesses to proper height (slightly above the child's shoulder) before installing the child restraint, please refer to P. 38 (Proper Position of the Shoulder Harnesses) & P. 39 (Shoulder Harnesses Height Adjustment).
2. Please adjust the child restraint to proper angle (3 positions for forward facing mode). Angle indication: With the top red dot and the bottom red dot aligned, as Fig. 25
3. When installing and adjusting the safety belts, make sure that both the shoulder belt and the waist belt are not twisted and will not keep the safety belts from being properly positioned.

1. Pull out the safety belt. Incline the child restraint rearward to any angle and thread the belt through two forward red safety-belt slots at the back of the child restraint shell. (Fig. 40)
2. Buckle the vehicle belt. (Fig. 41)
3. Open the lock-off device and insert the safety belt through it. (Fig. 42)
4. While pressing the child restraint, pull the belts to fasten the child restraint tightly and securely. (Fig. 43)
 - ! Please check by moving the child restraint back and forth.
 - ! The child restraint can not be used if the vehicle safety belt with female buckle is too long to tie the base. (Fig. 43.1)

The assembled safety belt is shown as **Fig. 44**

- ! Shoulder belt passes through Lock-off Device, confirm the Lock-off Device is pushed down, as **Fig. 44.1**
- ! Waist belt passes through the forward safety-belt slots, as **Fig. 44.2**
- ! The vehicle buckle tongue is engaged with the buckle correctly, as **Fig. 44.3**

v. Securing your Child in the child restraint

Note

1. When installing the child restraint in the forward facing mode, **DO NOT** use the small seat pad.
2. Please install the child restraint on the vehicle seat, and then put the child in the child restraint.
3. After the child is placed into the child restraint, check whether the shoulder harnesses are at proper height, please refer to **P. 38** (Proper Position of the Shoulder Harnesses) & **P. 39** (Shoulder Harnesses Height Adjustment).

1. Pull up the webbing adjuster, while pulling the shoulder harnesses to proper length. (**Fig. 12**)
Fig. 12.1 Webbing adjuster
2. Press the red button to disengage the buckle (**Fig 13.1**), and then leave the harnesses on the left side and right side of the seat. (**Fig. 13.2**)
3. Place the child in the child restraint and pass both arms through the harnesses. (**Fig. 45**)
4. Engage the buckle. (**Fig. 14**)
5. Pull down the adjustment webbing and adjust it to the proper length so that your child is snugly secured. (**Fig. 46**)
 - ! Make sure the space between the child and the shoulder harness is about the thickness of one hand.

Cleaning Method

- ! After removing the foam of small seat pad, please store it somewhere that the child can not access it.
- ! Please wash the soft goods with cold water under 30°C.
- ! Do not iron the soft goods.
- ! Do not bleach or dry clean the soft goods.
- ! Do not use undiluted neutral detergent, gasoline or other organic solvent to wash the child restraint. It may cause damage to the child restraint.
- ! Do not twist the soft goods to dry with great force. It may leave the soft goods with wrinkles.
- ! Please hang dry the soft goods in the shade.
- ! Please remove the child restraint from the vehicle seat if not in use for a long period of time. Put the child restraint in the shade and somewhere your child can not access it.

Detach Soft Goods

1. Remove the webbing cover, take off shoulder harnesses from T shaped piece to remove shoulder harnesses. Refer to **P. 39** (Disassembly of the Shoulder Harnesses).
2. Press the buckle, then remove the small seat pad. (**Fig. 47**)
3. Remove the fastening pieces on sides of the seat pad from the two slots on both sides of the body. (**Fig. 48**)
4. Remove the fastening pieces in front of the seat pad from the two slots on the bottom of the body. (**Fig. 49**)
5. Thread the adjustment webbing and harnesses on both sides out from the seat pad. (**Fig. 50**)
6. To remove the crotch strap cover, first locate the elastic on the inside of the crotch strap cover. Pull both the elastic and the crotch strap cover over the buckle to remove. (**Fig. 50**)
7. Thread the buckle out from seat pad slot for crotch strap to remove the seat pad. (**Fig. 51**)

To assemble soft goods in reverse steps. (**Fig. 52**)

Note

The logo for Joie, featuring the word "Joie" in a white, sans-serif font with a small leaf icon above the letter 'i'. A trademark symbol (TM) is positioned to the right of the word. The logo is set against a solid orange square background.

Joie™

bring the kids™

Share the joy at joiebaby.com

JK105_C0902SJ